



### **Science Arts & Métiers (SAM)**

is an open access repository that collects the work of Arts et Métiers Institute of Technology researchers and makes it freely available over the web where possible.

This is an author-deposited version published in: <https://sam.ensam.eu>  
Handle ID: <http://hdl.handle.net/10985/12540>

#### **To cite this version :**

Lorenzo CAPPELLI, Laurent GUILLAUMAT, Marco MONTEMURRO, Frédéric DAU - Multi-scale characterisation of material properties of composite fabrics through modal tests - In: Journées Nationales sur les Composites 2017, France, 2017-06-28 - Comptes Rendus des JNC20 - 2017

Any correspondence concerning this service should be sent to the repository

Administrator : [scienceouverte@ensam.eu](mailto:scienceouverte@ensam.eu)



# Caractérisation multi-échelle des propriétés matériaux de tissus composites par mesures vibratoires

## *Multi-scale characterisation of material properties of composite fabrics through modal tests*

Lorenzo Cappelli<sup>1</sup>, Marco Montemurro<sup>1</sup>, Frédéric Dau<sup>1</sup> et Laurent Guillaumat<sup>2</sup>

1 : Dépt. DUMAS, I2M CNRS UMR 5295  
Arts et Métiers ParisTech

Esplanade des Arts et Métiers, F-33400 Talence, France Cédex, France  
e-mail : lorenzo.cappelli@ensam.eu , marco.montemurro@ensam.eu et frederic.dau@ensam.eu

2 : Laboratoire angevin de mécanique, procédés et innovation (LAMPA)  
Arts et Métiers ParisTech

2, boulevard du Ronceray, 49035 Angers Cédex 01, France  
e-mail : laurent.guillaumat@ensam.eu

### Résumé

L'inconvénient principal des méthodes de caractérisation classiques est lié à l'impossibilité de pouvoir déterminer les constantes techniques d'élasticité dans le cas 3D : avec les essais classiques il est possible de déterminer les propriétés élastiques dans le plan du pli constitutif et avoir des valeurs approximées vis-à-vis des modules de cisaillement transverse. Aucune information ne peut être déduite sur les propriétés des phases constitutives à l'échelle microscopique. Pour contourner les restrictions propres aux essais de caractérisation standard, on propose une stratégie d'identification multi-échelle (MSIS, multi-scale identification strategy) permettant d'évaluer les propriétés matériaux à toute échelle caractéristique du problème sur la base d'essais non-destructifs effectués à l'échelle macroscopique. La méthode MSIS s'appuie d'une part sur une technique d'homogénéisation numérique et d'autre sur l'utilisation d'un algorithme au gradient pour résoudre le problème d'optimisation associé. Le problème est formulé comme un problème de minimisation sous contrainte : l'idée est celle de minimiser l'écart entre la réponse dynamique « numérique » (dépendant des propriétés du matériau aux échelles inférieures) et celle expérimentale tout en respectant les contraintes d'existence du tenseur de rigidité des phases constitutives à l'échelle microscopique. L'efficacité de la méthode sera prouvée à travers une campagne d'essais faites sur composites à renfort unidirectionnel.

### Abstract

One of the main issues of composite materials is related to the difficulty of characterising the material properties at mesoscopic and microscopic scales. Classical mechanical tests are not able to provide the full set of 3D properties : these tests can provide only the in-plane elastic properties of the constitutive lamina. Therefore, to go beyond the main restrictions imposed by standard destructive tests, this work deals with the problem of characterising the material properties of a multilayer composite plate, through a non-destructive modal test performed at the macro-scale : a multi-scale identification strategy (MSIS) is proposed. The MSIS aims at identifying the constitutive properties by exploiting the information restrained in the composite macroscopic dynamical response. The MSIS relies on the strain energy homogenisation technique of periodic media and on a gradient-based algorithm to perform the solution search. The identification problem is stated as a constrained inverse problem, where the objective function depends upon both experimental and numerical natural frequencies of the specimen. In this background, the optimisation variables are both geometrical and material properties of the constitutive phases composing the representative volume element. The effectiveness of the approach will be proven through a campaign of tests conducted on multilayer composites.

**Mots Clés :** Homogénéisation, Matériaux Composites, Optimisation, Analyse modal

**Keywords :** Homogenisation, Composite material, Optimisation, Modal analysis

## 1. Introduction

Nowadays, composite materials are widely used in several fields, from generic industrial and automotive applications to aerospace ones. This is mainly due to the high stiffness/mass and strength/mass ratios of composite materials when compared to steel or aluminium alloys.

One of the main issues of composite materials is linked to the difficulty of characterising the true material properties at meso and micro scales. The ASTM standard tests allow to find only meso-scale properties (i.e. at the ply-level), by employing destructive tests (tensile, compression, three/four points bending tests, etc.). Therefore such tests are not able to provide the full set of 3D elastic properties at each characteristic scale (micro and meso) : only the in-plane material properties together with an approximated value of the out-of-plane shear moduli at the ply-level can be estimated through these destructive tests.

In order to go beyond the main restrictions imposed by ASTM standard tests, the research activity here presented focuses on the development of a multi-scale identification strategy (MSIS) based on an inverse problem : the micro-scale properties and the related variability (due to the manufacturing process) can be characterised, starting from non-destructive experimental tests conducted at the macro-scale. In this way, the full set of material properties defining the behaviour of the composite can be evaluated at each characteristic scale. The experimental tests considered in this work are non-destructive modal tests : the goal is to exploit the information restrained in the natural frequencies of the specimen (i.e. a multilayer plate) to identify the material parameters at the lower scales (meso and micro).

The inverse problem is stated as a constrained optimisation problem in which the distance between the measured natural frequencies and their numerical counterparts is minimised. The eigenfrequencies provided by the FE model of the structure depends upon the material parameters of the constitutive layers that are calculated by means of a numerical homogenisation procedure performed on a representative volume element (RVE) of the material : in this way the true optimisation variables are both the material and the geometrical properties of the constitutive phases of the RVE. Indeed, such an identification strategy is widely applied in literature, see [1], [2], [3] and [4], for characterising the elastic properties of the constitutive lamina, but it has never been generalised to characterise the material and geometrical features (and the related variability) of the microstructure of such materials. The paper is structured as follows : section 2 gives a general overview of the MSIS : the purposes, the methodology, the homogenisation scheme and the finite element (FE) models at each characteristic scale are briefly described. The numerical results are summarised in the section 3 and compared with ASTM standard test results. Section 4 ends the paper with some concluding remarks.

## 2. THE MULTI-SCALE IDENTIFICATION STRATEGY

As stated previously, the MSIS aims at characterising the material properties at each scale of the composite on the basis of a non-destructive test carried out at the macroscopic scale. In particular, the MSIS exploits the information restrained into the dynamical response of a multilayer plate, in terms of its natural frequencies. Indeed, the idea is to minimise the distance between the experimental eigenfrequencies of the specimen and their numerical counterparts which depends upon the material properties of the constitutive phases of the composite (microscopic scale).

The MSIS is applied to a reference multilayer plate made of unidirectional laminae of which the material data, the geometry and the test conditions are taken from [1]. The material properties of the constitutive lamina have been characterised also through a standard testing procedure in accordance with the relevant ASTM specification : the average value as well as the coefficient of variance (c.o.v., i.e. the ratio between the standard deviation and the average value) are summarised in (Tab. 1).

Tab. 1. Meso-scale properties of the constitutive layer determined through the ASTM test [1].

Mesoscale	Average value	C.o.v. [%]
$E_1$ [GPa]	146.503	0.72
$E_2$ [GPa]	9.223	1.19
$G_{12}$ [GPa]	6.836	3.16
$\nu_{12}$	0.306	0.19

Tab. 2. Geometrical parameters of the specimen.

Parameters	Values
$a_0$	205 mm
$t$	1 mm
$h_e$	2.1 mm
$b_e$	5.0 mm
<i>mass</i>	64.72 gr

Regarding the measured natural frequencies, they have been obtained through a standard modal test on a sample whose geometry is illustrated in (Fig. 1). In the vibration test, a hand-held impulse hammer is used to excite the composite plate at different locations. A force transducer is attached on the hammer head to measure the input force while an accelerometer is located at different points on the plate to pick up the vibration response data. The accelerometer mass is around the 0.2% of the plate mass, then it is considered to be negligible. More details on the experimental test can be found in [1].

The plate is composed of eight layers with the stack  $[(0/90)_2]_S$  and it is elastically constrained by a sponge at each edge having an elastic Young's modulus  $E_e = 2.028 \text{ MPa}$ . The geometrical parameters of the specimen (illustrated in (Fig. 1)) are listed in (Tab. 2), while the measured natural frequencies (average value and coefficient of variance) are given in (Tab. 3).

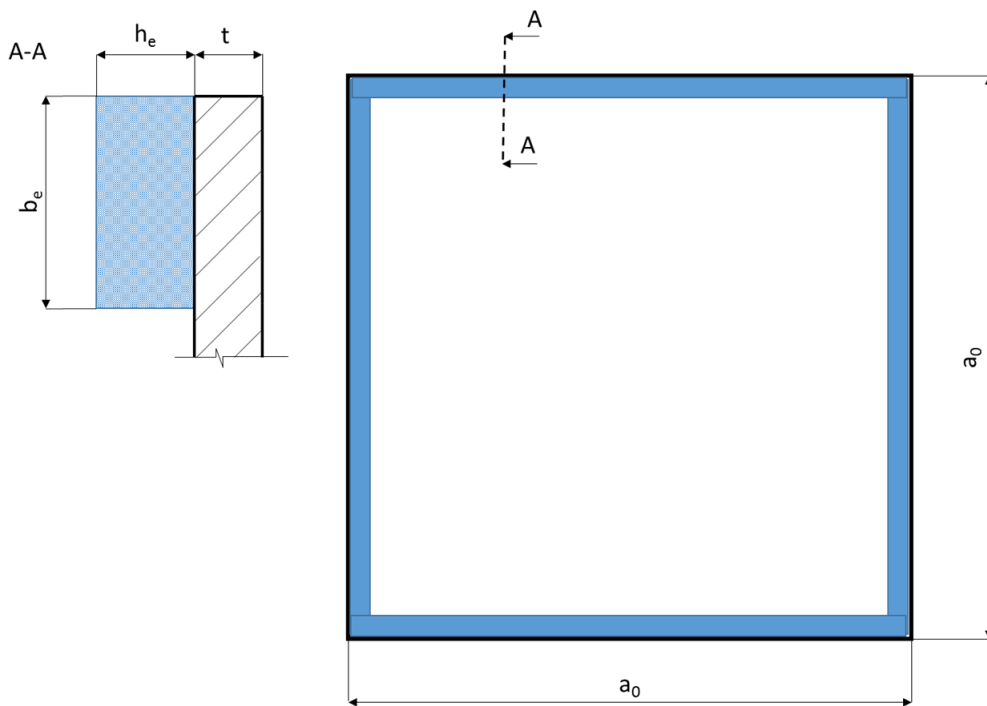

Fig. 1. Vibration test scheme.

## 2.1. Mathematical formulation and numerical strategy

The MSIS aims at finding the material properties of the constitutive phases of the composite (i.e. at the micro-scale) by means of a set of experimental data provided by a macroscopic measurement, i.e. through a standard non-destructive modal test.

In this background, the problem of the multi-scale identification of the composite mechanical properties is stated as a constrained minimisation problem. The inverse problem considered here belongs to the class of minimum distance problems : the goal is to find, through a gradient-based process, the

Tab. 3. Plate measured natural frequencies (taken from [1]).

$f_i$	Values [Hz]	C.o.v. [%]
$f_1$	122	0.67
$f_2$	281	0.43
$f_3$	364	0.75
$f_4$	469	0.11
$f_5$	574	0.47
$f_6$	710	0.57
$f_7$	773	0.59

elastic constants of the RVE of the material by minimising the distance between the real model and the numerical one. This distance depends upon the measured and computed eigenfrequencies. In particular, the characterisation is carried out through the measurement of a set of  $N$  natural frequencies of the reference structure described in section 2, which represent the system response.

Therefore the goal of the multi-scale inverse problem is the minimisation of the difference between the dynamical response of the physical system and that of the FE model of the specimen (i.e. the macro-scale FE model) which simulates the system response as a function of the elastic constants defined at the micro-scale. The set of material properties minimising (i.e. putting to zero) this difference is assumed to be the set of the actual physical parameters to be identified.

It is noteworthy that the equivalent material properties of the constitutive layers are affected by both the geometrical and the material parameters of the constitutive phases of the RVE. Therefore the link between the two scales is represented by a homogenisation phase performed on the RVE of the material (i.e. the micro-scale FE model) in order to compute the effective elastic properties of the ply, by means of the well-known strain energy homogenisation technique of periodic media described in [5]. The components of the ply stiffness tensor (meso-scale) are evaluated from the volume-average components of the stress field of the RVE (micro-scale) by imposing the proper set of periodic boundary conditions (BCs) [5]. This strategy is rather classical and has already been utilised in other works, see [6], [7], [8] and [9].

In this background the optimisation variables are the material properties of the constitutive phases (i.e. the fibre and the matrix, whose behaviour is assumed to be linear elastic isotropic) which are collected into the vector of optimisation variables :

$$\vec{x} = \left\{ \frac{E_f}{E_f^{\text{ref}}}, \frac{E_m}{E_m^{\text{ref}}}, \nu_f, \nu_m \right\}, \quad (\text{Eq. 1})$$

where  $E_f$ ,  $E_m$ ,  $\nu_f$  and  $\nu_m$  are the young modulus and the Poisson's ratio of fibre and matrix, respectively, whilst  $E_f^{\text{ref}} = 460$  GPa and  $E_m^{\text{ref}} = 7.92$  GPa are the reference values of the Young's moduli. The lower and upper bounds of the components of the vector  $\vec{x}$  (due to the positive definiteness of the stiffness tensor of each constitutive phase) are defined as :

$$0 \leq \frac{E_f}{E_f^{\text{ref}}} \leq 1, \quad 0 \leq \frac{E_m}{E_m^{\text{ref}}} \leq 1, \quad (\text{Eq. 2})$$

$$-1 < \nu_f < 0.5, \quad -1 < \nu_m < 0.5. \quad (\text{Eq. 3})$$

Finally, the problem is stated as a constrained non-linear programming problem (CNLPP) as follows :

$$\begin{cases} \min_{\vec{x}} \text{obj}(\vec{x}), \\ \vec{x}_{LB} \leq \vec{x} \leq \vec{x}_{UB}. \end{cases} \quad (\text{Eq. 4})$$

In (Eq. Eq. 4)  $obj(\vec{x})$  is the objective function which writes

$$obj(\vec{x}) = \sum_{k=1}^N \left[ \frac{f_k - \bar{f}_k}{\bar{f}_k} \right]^2, \quad (\text{Eq. 5})$$

where  $f_k$  is the  $k^{\text{th}}$  natural frequency provided by the FE model of the plate and  $\bar{f}_k$  is its experimental counterpart.

Concerning the optimisation scheme, a classical gradient-base algorithm has been utilised to perform the solution search. The numerical tool is the *active-set* algorithm implemented in the MATLAB<sup>®</sup> optimisation toolbox [10]. The optimisation tool considered for the problem at hand is a Quasi-Newton method, which is a second order optimisation strategy in which an approximated expression for the inverse of the Hessian matrix is employed. The active-set algorithm has been interfaced with the FE models (micro and macro scales) of the composite which have been built within the ANSYS<sup>®</sup> environment, according to the logical flow-chart illustrated in (Fig. 2).

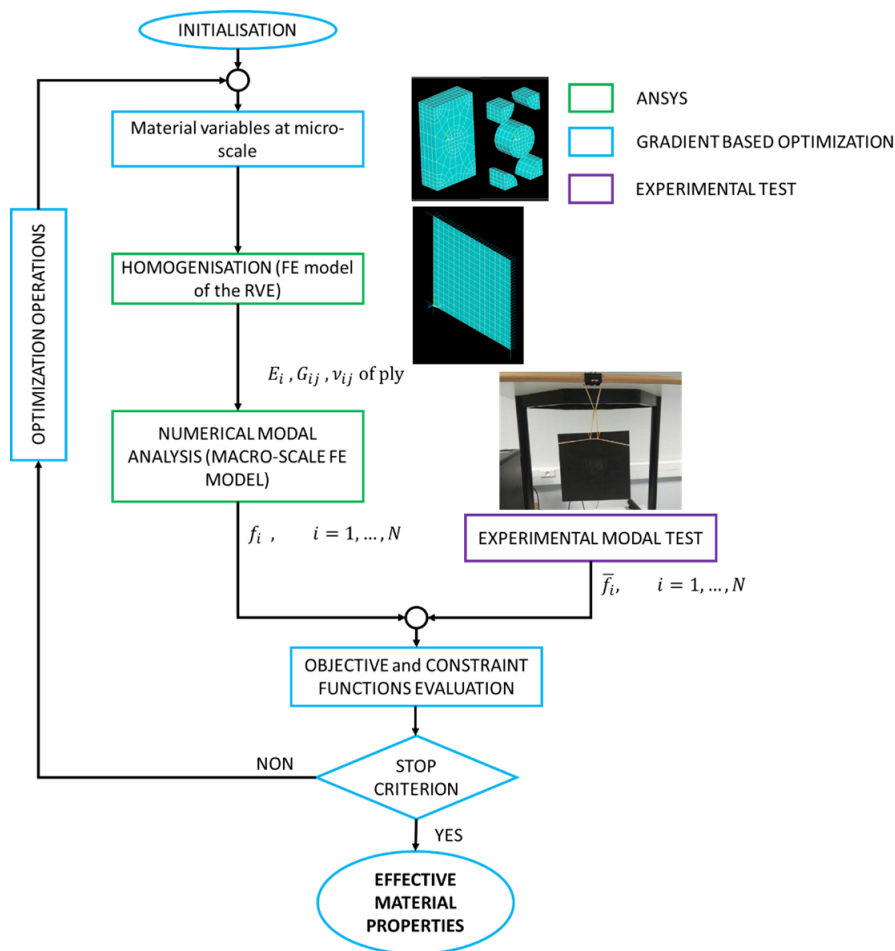

Fig. 2. Logical flow of the MSIS.

## 2.2. THE MICRO-SCALE FE MODEL

In this work a FE-based approach has been chosen as a numerical homogenisation technique to determine the effective elastic properties of the constitutive lamina. Due to the periodicity of the microstructure of the composite, the homogenisation strategy is applied to the RVE illustrated in (Fig. 3). The RVE is defined as the minimum volume which ensures that the obtained results are representative of the heterogeneous media, at the upper scale. At the mesoscopic scale (i.e. at the ply level) the heterogeneous medium is replaced by an equivalent homogeneous anisotropic virtual

material characterised by the elastic properties determined during the homogenisation phase and which will depend upon the geometrical and material parameters of the RVE.

The stiffness tensor of the ply are determined using the strain energy homogenisation technique of periodic media [5]. The main hypothesis of this technique is that the repetitive unit of the periodic structure and the corresponding unit volume of the homogeneous solid undergo the same deformation having, hence, the same strain energy.

In this study, the real random micro-structure of the lamina (which is usually characterised by misalignments of the fibres, porosities, damaged zones, etc.) is not taken into account and the topology of the RVE is described by a perfect hexagonal array, see (Fig. 3).

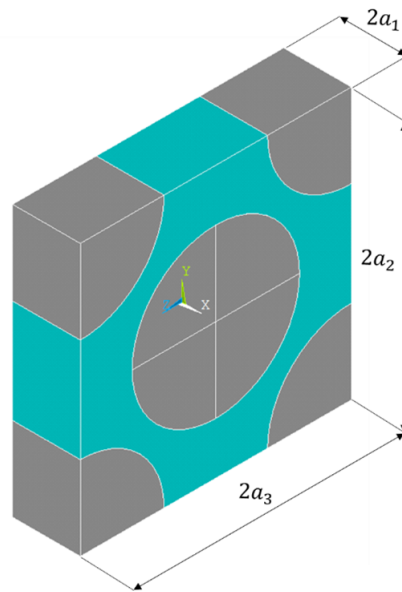

Fig. 3. The Reference RVE.

The FE model of the RVE has been realised within the commercial FE code ANSYS®. A 20-nodes solid element SOLID 186 with three Degrees Of Freedom (DOFs) per node has been utilised. The model along its structured mesh is illustrated in (Fig. 4).

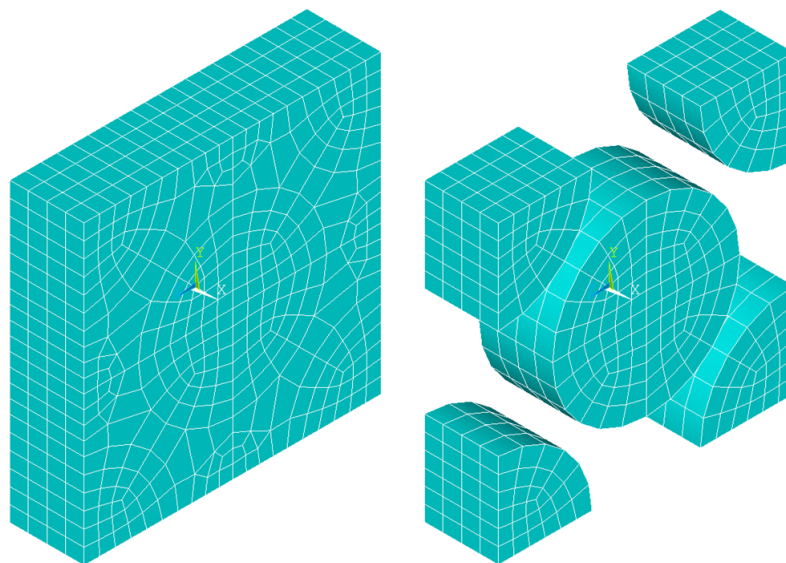

Fig. 4. FE model of the RVE, micro-scale.

In order to evaluate the components of the stiffness matrix  $[C]$ , of the lamina, the RVE has been subjected to an average strain field  $\varepsilon_{ij}^0$  (tensor notation). The six components of the average strain are applied by considering the periodic boundary conditions (BCs) on the RVE [5].

$$\begin{aligned} u_i(a_1, x_2, x_3) - u_i(-a_1, x_2, x_3) &= 2 \cdot a_1 \cdot \varepsilon_{i1}^0, & -a_2 \leq x_2 \leq a_2, -a_3 \leq x_3 \leq a_3, & i = 1, \dots, 3, \\ u_i(x_1, a_2, x_3) - u_i(x_1, -a_2, x_3) &= 2 \cdot a_2 \cdot \varepsilon_{i2}^0, & -a_1 \leq x_1 \leq a_1, -a_3 \leq x_3 \leq a_3, & i = 1, \dots, 3, \\ u_i(x_1, x_2, a_3) - u_i(x_1, x_2, -a_3) &= 2 \cdot a_3 \cdot \varepsilon_{i3}^0, & -a_1 \leq x_1 \leq a_1, -a_2 \leq x_2 \leq a_2, & i = 1, \dots, 3. \end{aligned} \quad (\text{Eq. 6})$$

These BCs results in a complex strain field inside the RVE. The applied average strains always meet the following condition :

$$\bar{\varepsilon}_{ij} = \frac{1}{V} \cdot \int_V \varepsilon_{ij} dV = \varepsilon_{ij}^0. \quad (\text{Eq. 7})$$

For the homogenised material, the relationship between average stress and strain (Voigt's notation) is :

$$\bar{\sigma}_\alpha = C_{\alpha\beta} \cdot \bar{\varepsilon}_\beta, \quad \alpha, \beta = 1, \dots, 6. \quad (\text{Eq. 8})$$

The components of the stiffness matrix  $[C]$  are determined by solving six static analyses on the RVE by imposing the previous periodic BCs, where only one component of the strain  $\varepsilon_\beta^0$  is different from zero for each of the six problems. For each static analysis the volume-averaged value of each component of the stress field  $\bar{\sigma}_\alpha$  (Voigt's notation) can be easily computed and the stiffness matrix of the equivalent homogeneous materials can be calculated one column at time :

$$C_{\alpha\beta} = \frac{\bar{\sigma}_\alpha}{\varepsilon_\beta^0} = \frac{1}{V \cdot \varepsilon_\beta^0} \cdot \int_V \sigma_\alpha(x_1, x_2, x_3) dV, \quad \alpha, \beta = 1, \dots, 6. \quad (\text{Eq. 9})$$

The engineering moduli of the equivalent homogeneous anisotropic continuum can be calculated starting from the components of the compliance matrix  $[S]$  as :

$$[S] = [C]^{-1} \quad (\text{Eq. 10})$$

For more details on the homogenisation procedure the interested reader is addressed to [5]. Finally, after a preliminary mesh sensitivity study the average size of the elements has been chosen in order to obtain an overall number of DOFs equal to 19551.

### 2.3. THE MACRO-SCALE FE MODEL

As stated previously, the multi-scale identification procedure is applied to a reference multilayer composite plate, taken from [1]. The macro-scale FE model of the multilayer plate has been built by using a combination of SHELL281 (shell elements with eight nodes and six DOFs per node) and COMBIN14 elements. The latter is a line element with two nodes and a single DOF per node and it acts as an elastic spring on the edges, to simulate the sponge effects. The FE model is shown in (Fig. 5).

As depicted in (Fig. 1), the effective length of the plate edges is  $a = a_0 - b_e$  which is the edge length of the FE model of the plate (Fig. 5). It is noteworthy that, in order to simulate the elastic pad effects, elastic and torsional springs are placed along the plate edges. The translational and torsional spring constants,  $k_L$  and  $k_R$ , respectively are calculated as :

$$k_L = \frac{E_e \cdot b_e}{h_e}, \quad k_R = \frac{E_e \cdot b_e^3}{12 \cdot h_e}. \quad (\text{Eq. 11})$$

In order to get the numerical values of the first  $N$  natural frequencies of the plate an undamped modal analysis has been performed on the multilayer plate. Finally, after a preliminary mesh sensitivity study the size of the elements has been chosen in order to have the maximum aspect ratio equal to 8.



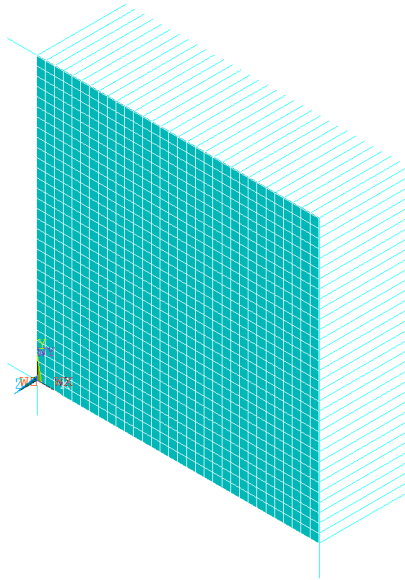

Fig. 5. FE model of the multilayer plate, macro-scale.

### 3. NUMERICAL RESULTS

The effectiveness of the proposed MSIS is proven by considering a reference composite plate taken from [1]. The geometrical and material parameters of this plate are given in Section 2.1. In [1] the author carried out a modal test by extracting the first  $N = 7$  natural frequencies of the multilayer plate, see (Tab. 3). The fibre volume fraction is equal to 0.6. However the purpose of their work was the identification of the elastic properties of the constitutive lamina [1]. Here the identification procedure is generalised by attempting to characterise the material properties of the constitutive phases (fibre and matrix) at the microscopic scale on the basis of the macroscopic dynamical response of the composite. The results of the optimisation process are listed in (Tab. 4- 6). Both experimental and numerical values of the eigenfrequencies are listed in (Tab. 4). The optimum value of the material properties at both microscopic and mesoscopic scales are listed in (Tab. 5) and in (Tab. 6), respectively. The maximum relative error on the eigenfrequencies is relatively small (about 2% on the first natural frequency).

In order to check the effectiveness and the reliability of the MSIS, the micro-scale material properties found at the end of the optimisation process have been compared to the value of the elastic constants of both fibre and matrix provided by technical data sheet available on the net [11]. However, only the Young's modulus of the fibre can be deduced from the technical data sheet for the fibre constituting the elementary ply of the multilayer plate considered in [1] (the rest of the data are no longer available). From the data sheet [11] this value is  $E_f = 230$  GPa. When looking at the micro-scale results summarised in (Tab. 5) the relative error is about 4%. However, when looking at the value of the effective elastic properties of the constitutive layer for the optimum solution a discrepancy occurs between the numerical results and the experimental data provided by ASTM standard tests [1], as summarised in (Tab. 6). In particular the relative error ranges from 14% (for  $E_{22}$ ) to about 6% (for  $\nu_{12}$ ). This discrepancy is related to the following aspects :

- the objective function is highly non-convex. In fact a given set of elastic properties of the ply (and thus a given set of eigenfrequencies of the plate which depends upon these parameters) can be got by considering different combinations of  $E_f$ ,  $\nu_f$ ,  $E_m$  and  $\nu_m$ . Therefore only local minima can be estimated through a gradient-based approach : this strategy must be coupled with a more general global optimisation approach (e.g. a genetic algorithm) in order to catch true global minima ;
- the behaviour of the fibre is not isotropic. Normally the fibre shows a transverse isotropic

behaviour which should be taken into account within the strategy : when considering a more general constitutive behaviour (e.g. transverse isotropic, orthotropic, etc.) several optimisation constraints must be considered within the mathematical formulation of the optimisation problem [6];

- a measurement error on the experimental values of the natural frequencies can strongly affect the final result (in terms of identified material properties) : to go beyond this limitation the measure of the eigenfrequencies of the specimen should be repeated many times (in order to have a statistically significant result);
- the number of natural frequencies is not enough to perform in a proper way the identification process. Normally a certain level of redundancy (in terms of observed states) should be ensured : the number of measurement should be greater than or equal to twice the number of the parameters to be identified;
- the nature of the stacking sequence of the specimen strongly affects the mode shapes and hence the related natural frequencies : the modal test should be repeated on different specimens (characterised by different stack) in order to ensure that each elastic constant of the ply has (more or less) the same influence on the full set of natural frequencies.

Tab. 4. Natural frequency results.

Frequency number	$f_{TEST}$ [Hz]	$f_{FEM}$ [Hz]	error [%]
$f_1$	122	119.48	2.066
$f_2$	281	283.12	-0.7544
$f_3$	364	363.93	0.01923
$f_4$	469	470.10	-0.2345
$f_5$	574	579.94	-1.035
$f_6$	710	715.51	-0.7761
$f_7$	773	772.44	0.07245
Object function value	0,0006556		

Tab. 5. Micro-scale optimisation results.

$E_f$ [GPa]	$E_m$ [GPa]	$\nu_f$	$\nu_m$
220	1.501	0.499	-0.6158

Tab. 6. Meso-scale optimisation results.

Elastic moduli	MSIS values	ASTM test values	Percentage errors [%]
$E_{11}$ [GPa]	133.6	146.503	-8.81
$E_{22}$ [GPa]	10.52	9.223	14.1
$G_{12}$ [GPa]	7.579	6.836	10.9
$\nu_{12}$	0.3246	0.306	6.08
$\nu_{23}$	0.03671	-	-

#### 4. CONCLUSIONS AND FUTURE DEVELOPMENTS

In this work a multi-scale identification strategy (MSIS) able to characterise the elastic properties of composite materials (at each characteristic scale) has been presented. The MSIS relies on the one hand on the strain energy homogenisation technique of periodic media and on the other hand on the experimental results provided by a single non-destructive modal test. The method has been applied to

a reference multilayer plate made of unidirectional carbon/epoxy pre-preg plies, in order to validate its effectiveness. The elastic properties of the composite have been characterised at both micro and meso scales and a good agreement between the non-destructive modal test and standard ASTM tests is observed : the equivalent elastic properties of the ply (meso-scale) are identified with a good accuracy (the maximum relative error being 14% on  $E_2$ ). Furthermore, thanks to the proposed multi-scale identification approach it is possible to retrieve the effective properties of the constitutive phases of the RVE, which cannot be obtained with standard ASTM tests and which represents the major drawbacks of classical destructive tests. Nevertheless, the proposed strategy constitutes just a "first attempt" : the methodology must be generalised and ameliorated in order to catch the true behaviour of the material of the constitutive phases at the microscopic scale. To this purpose, the next steps of the present study will focus on the integration, within the FE models, of the following features :

- linear elastic transversal isotropic behaviour for the fibre ;
- linear elastic/viscoelastic orthotropic behaviour for the matrix ;
- non-linear material behaviour ;
- variability effects induced by the manufacturing process (e.g. local variation of the fibre volume fraction, misalignments of fibres, variation of the plies orientation angles, etc.).

Finally, as stated in the previous section, due to the non-linearity and non-convexity of the objective function a more general optimisation tool must be utilised to perform the solution search for the problem at hand. The next step will be the utilisation of a more suited hybrid optimisation strategy (genetic + gradient-based) able to find the true global minimum.

### Acknowledgements

This project has received funding from the European Union's Horizon 2020 research and innovation programme under grant agreement No 642121.

### Références

- [1] C. Lee, T. Kam « Identification of mechanical properties of elastically restrained laminated composite plates using vibration data », *Journal of Sound and Vibration* Vol. 295 n° -, pp. 999–1016, 2006.
- [2] L. Xing, G. Zhidong, L. Zengshan, L. Lu « A new stress-based multi-scale failure criterion of composites and its validation in open hole tension tests », *Chinese Journal of Aeronautics* Vol. 27 n° 6, pp. 1430–1441, 2014.
- [3] V. Andy, C. Brian N., L. Stepan V., V. Dirk « Multi-scale modelling strategy for textile composites based on stochastic reinforcement geometry », *Computer Methods in Applied Mechanics and Engineering* Vol. 310 n° -, pp. 906–934, 2016.
- [4] Z. X.-Y., G. P.D., U. Z., K. L., P. C.J. « Exploiting the benefits of multi-scale analysis in reliability analysis for composite structures », *Composite Structures* Vol. 155 n° -, pp. 197–212, 2016.
- [5] E. Barbero « Finite element analysis of composite materials », *CRC Press, Taylor and Francis Group* Vol. n° -, pp. -, 2007.
- [6] M. Montemurro, H. Nasser, Y. Koutsawa, S. Belouettar, A. Vincenti, P. Vannucci « Identification of electromechanical properties of piezoelectric structures through evolutionary optimisation techniques », *International Journal of Solids and Structures* Vol. 49 n° 13, pp. 1884–1892, 2012.
- [7] M. Montemurro, M. Catapano, D. Doroszewski « A multi-scale approach for the simultaneous shape and material optimisation of sandwich panels with cellular core », *Composite Part B Engineering* Vol. 91 n° -, pp. 458–472, 2016.
- [8] A. Catapano, M. Montemurro « A multi-scale approach for the optimum design of sandwich plates with honeycomb core. Part I : Homogenisation of core properties », *Composite structures* Vol. 118 n° -, pp. 664–676, 2014.
- [9] A. Catapano, M. Montemurro « A multi-scale approach for the optimum design of sandwich plates with honeycomb core. Part II : The optimisation strategy », *Composite structures* Vol. 118 n° -, pp. 677–690, 2014.
- [10] I. The MathWorks « Optimization Toolbox User's Guide », *MATLAB* Vol. 1 n° -, pp. 1–916, 2017.
- [11] [Online] « <http://www.torayusa.com> », *Torayca online web site* Vol. - n° -, pp. -, 2017.
- [12] K. Kong, Z. Ong, S. Khoo, Z. Ismail, B. Ang, W. Chong, S. Noroozi, A. Rahman « Identification of material properties of orthotropic composite plate using hybrid non-destructive evaluation approach », *Materials Research Innovations* Vol. - n° 18, pp. 423–428, 2014.
- [13] E. Rizzo « Optimization methods applied to the preliminary design of innovative, non conventional aircraft configurations », Ph.D. thesis, Università di Pisa, 2009.