



Science Arts & Métiers (SAM)

is an open access repository that collects the work of Arts et Métiers Institute of Technology researchers and makes it freely available over the web where possible.

This is an author-deposited version published in: <https://sam.ensam.eu>
Handle ID: <http://hdl.handle.net/10985/6534>

To cite this version :

Jean-François OMHOVER, Marc TRELA, Améziane AOUSSAT - Integration of EcoDesign in the early steps of the innovation process - International Journal of Environmental Technology and Management - 2012

Any correspondence concerning this service should be sent to the repository

Administrator : scienceouverte@ensam.eu



Integration of EcoDesign in the early steps of the innovation process

Marc Trela*

Bosch Thermotechnology, Bosch group,
124-126 rue de Stalingrad,
93711 Drancy Cedex, France
E-mail: marc.trela@gadz.org
*Corresponding author

**Jean-François Omhover
and Améziane Aoussat**

Arts et Métiers ParisTech, LCPI,
151 bd de l'Hopital,
75013 Paris, France
E-mail: jean-francois.omhover@ensam.eu
E-mail: ameziane.aoussat@ensam.eu

Abstract: EcoDesign is not easily fitting in the Innovation process, mostly owing to the dedicated time and resources required for learning and applying the EcoDesign-related knowledge when fast decision-making is occurring in early stages of product development and as there is only a low level of information on the new product to be made. In this paper, we propose a way to integrate EcoDesign in the early steps of the innovation process, while taking into account available processes and tools. A pre-assessment-based approach is brought using product typology, flow study and internal Functional Analysis (FA). We illustrate our proposition with an example on a new heating appliance design. Using this case study, we show how the innovation requirements could be met and how standard tools can be employed along the product development phases (Idea Management, Feasibility Assessment and Time To Market).

Keywords: LCA; life cycle analysis; EcoDesign; innovation; tools; hybrid; pre-assessment; process; product typology; design for environment.

Reference to this paper should be made as follows: Trela, M., Omhover, J-F. and Aoussat, A. (xxxx) 'Integration of EcoDesign in the early steps of the innovation process', *Int. J. Environmental Technology and Management*, Vol. X, No. x, pp.xxx-xxx.

Biographical notes: Marc Trela is an Industrial Engineer responsible for innovative product development at Bosch Thermotechnology in France. He is a PhD candidate in the New Product Design and Innovation Laboratory of Arts et Métiers ParisTech and interested in the development of innovative eco-friendly heating appliances through creative techniques such as TRIZ (Theory of Inventive Problem Solving).

Jean-François Omhover is an Assistant Professor in the Product Design and Innovation Laboratory, in Arts and Métiers ParisTech. His research activity is focused on the development of decision supporting tools for design and innovation, based on machine learning techniques.

Améziane Aoussat is the Director of the Product Design and Innovation Laboratory, in Arts and Métiers ParisTech. He has developed several design methodologies related to product design and management of innovation, extensively tested in French industry.

1 Introduction

Industry is facing new issues in product development. In the market of heating appliances for instance, product promotion is driven by CO₂ emission reduction, and primary energy consumption.

However, this need for performance according to these new indicators is opposed to other critical factors, such as the fact that dedicated time, knowledge and resources, have to be allocated to this EcoDesign approach and there is a need to make decisions quickly in the first step of the development of an innovative product together with a lack of environmental-related information with a new product.

2 State-of-the-art

2.1 Industrial context

Environmental considerations are growing (Millenium Ecosystem Assessment, 2005). Strategic product development is more and more driven by environmental considerations (new customer behaviour, legislation change, incentives and policy).

Industrial environmental approach is often led by guidelines, such as Design for Environment (DfE), suitable for re-engineering, modifications, but hardly applicable to the early steps of a new product design, where the information about the new product to come is unclear or partially undefined.

Considering the heating appliance economy sector, we can also notice a strong influence of the new available technologies using renewable energy, whose performance assessments are currently being synthesised within the extension of the European Energy using Products policy and its labelling considerations (Kemna et al., 2007).

Regarding sales regions, new products will also have to meet specific requirements to encounter commercial success. For instance in France, they will have to comply with the national roadmap for residential energy consumption (Ministère de l'écologie, de l'énergie, du développement durable et de l'aménagement du territoire, 2008).

As an example, to achieve the objectives in new built houses, the heating appliances will have to respect the low-energy house standards in 2012 and passive in 2020. However, for this assessment of system performances, it is needed to go further than the designed product boundaries. In our illustration, for domestic heating appliances, we will have to consider new system boundary conditions linked to the sales region (such as representative weather conditions, building characteristics and energy prices), include

Integration of EcoDesign in the early steps of the innovation process

new stakeholders in our environmental assessment, and use specific tools. Once again, if this attempt is not guided, then the product evaluation might require as much effort as the product design (Le Pochat et al., 2005).

As a conclusion, by orienting towards EcoDesign, companies face new performance indicators (such as CO₂ emission, primary energy consumption and shares of renewable energy), they also refer to a new customer behaviour, and require the use of a new related knowledge within a systemic approach gathering different stakeholders while mostly little time, resource and expertise are available for innovative projects.

2.2 Processes supporting eco-design

EcoDesign is globally based on two different approaches applied together: Life Cycle (LC) and multicriteria approaches (Grisel and Duranthon, 2001).

LC approach consists in a flow study during the lifetime of a product, decomposed in phases, from cradle to grave. The main idea is to identify and reduce the entering flow (materials and energy) and the outgoing (air, water and soil pollution) of this assessment.

Multicriteria approaches are based on the different factors that are impacts or impact indicators, like green house effect increase or non-renewable material depletion.

EcoDesign approaches are supported with dedicated product development processes (Bakker, 1995). Some are derived from previous design processes (Janin, 2000) and integrate new key steps and specific information related to the environmental aspect. Some other even integrate the learning process required for tackling this new knowledge base (Le Pochat et al., 2005).

Kobayashi and Wafa Samet (Kobayashi, 2006; Samet et al., 2009) already focused on the early steps of design and proposed an eco-innovation process. This brings a qualitative assessment of a product far less detailed than Life Cycle Analysis (LCA) results but orienting the designer (Samet et al., 2009). Indeed, it is necessary to tackle environmental concerns at the earliest stages of product requirements establishment, even though the most EcoDesign tools are not suitable for this stage (Reine Karlsson, 2005).

2.3 Tools

There are lots of different EcoDesign tools, categorised (Janin, 2000) as following:

- evaluation tools
- improvement tools
- strategic tools
- communication tools.

Even in a common category, these tools are not equivalent, it is thus hard for the company to make a choice, which will be based on needs, internal capacity and performance level of the tool (reliability, sensitivity, precision) (Le Pochat et al., 2005).

Assessment tools enable the comparison of the existing products, or a product against a norm, a recommendation, or even legislation. They also allow identifying the weakest points of the product and find a path towards improvement (Grisel and Duranthon, 2001).

There is thus a great interest for companies to master at least one of these tools. The most known of these environment assessment tools is the LCA.

2.3.1 *Life Cycle Analysis (LCA)*

ISO 14040 (AFNOR, 1997) defines LCA as the compilation and evaluation of inputs and outputs, as well as the potential environmental impacts of the system during its lifetime.

LCA makes possible the objective and quantitative evaluation of the impacts of a selected system. However, this tool requires a high-initial investment in time and skills (expertise), because its completeness characteristic implies a high degree of complexity (Grisel and Duranthon, 2001).

2.3.2 *Simplified LCA*

Another EcoDesign tool frequently met is simplified LCA. This LCA-based tool has quite some advantages: it reduces the time required for evaluation, and makes interpretation easier. It is generally presented as software and can be used for environmental improvement (Le Pochat et al., 2005). Its drawback is that simplification is reducing the precision of the final result and the confidence the designer can have in it. Actually, it is hard and even almost impossible for a company without any expertise on this topic to have the background required for the choice in the most interesting simplification hypothesis.

Therefore, the main weaknesses of simplified LCA tools are then their simplification hypothesis and the set of indicators expressing their results. For a company not having the needed internal knowledge, an alternative could be to rely on a dedicated technical centre (Bensafi et al., 2005), gathering several companies selling comparable products (at least in terms of environmental profile creation), for which the access to knowledge and accurate data would be easier. Moreover, even for a bigger company, it is always interesting to benefit from the return of experience of a tool used on several products close to the ones it produces.

As explained earlier, most of the EcoDesign tools focus on the detailed design of a product, which is to say after the agreement on the product specifications. However, a large amount of the future impacts of the product are already fixed at this stage (Conrad Luttrupp, 2005). Once more, we must notice that these tools are not directly usable by designers (Le Pochat et al., 2005) unless they invest a lot of effort.

If a standard method is not applicable in the case of a new product EcoDesign then we should investigate the available tools at this stage and how EcoDesign principles could be integrated.

2.3.3 *Functional analysis*

When a FA is performed on the early stages of product design, the designer has to study all the different stages or phases of the product life and its interaction with the elements that it is interfering with to express the functions a product has to meet. This is in accordance with the EcoDesign approaches described earlier, as impacts of the product may also be described in a wide set of indicators (multi-criteria approach).

Some of the specific tools of FA are adapted to the representation, understanding and evaluation of the product functions as a flow diagram study (Bauer et al., 2008). As the requirements of the EcoDesign are met (LCA and multi-criteria) the model of FA could be used as an EcoDesign tool for early stage of product development (specification establishment and technical solutions evaluation).

2.4 Problem synthesis

As we saw through the industrial context and state-of-the-art, our problem is that:

- Companies have difficulty in handling EcoDesign with their available resources (time and expertise)
- New stakeholder relationships are interfering
- The two concepts of EcoDesign (LC and multicriteria) are not easy to manipulate in early design steps with the current tools, even though some other approaches (FA), already based on these principles, are easier to apply.

Regarding available tools, Design for Environment guidelines are not directly adaptable to the early steps of product design because they refer to considerations that are not determined yet or they tackle the whole product life cycle, without specific adaptation to the product itself.

For instance, it is not always relevant to ask if a new part comply with some environmental legislation (REACH, RoHs ...) when it has not even been designed or specified yet.

3 Hypothesis

3.1 Product typology

To complete a full LCA, with the aim of the EcoDesign of the product, time and expertise and thus resources have to be available. Hardly any EcoDesign tools are suitable for the early development phase. It is then necessary to find a way of reducing assessment time and targeting the most important product life phases and environmental impacts.

One of these approaches is product typology. Every product is attached to an environmental profile (Le Pochat et al., 2005).

Other ways can be found such as using previous LCA computed on similar products (Bensafi et al., 2005).

Furthermore, environmental profile study enables the selection of the most accurate design approach and it can be established by a project team (AFNOR, 2009) even if there is no environmental expert in it.

3.2 Flow study and internal functional analysis

As explained earlier, EcoDesign principle is based on the notion of a multi-criteria flow study during the lifetime of the product and some design tools already focus on the flow within the designed system.

The gap between these FA tools and EcoDesign tools is that it is almost impossible to gather all the information required for this flow assessment. The reason for this is that the designer is often only one of the stakeholders of the product.

This weakness is tackled thanks to PRE-assessment.

3.3 *Pre-assessment*

In the design of many different products, when diagram flow tools are applied, we can see that the inputs and outputs of the systems (i.e., their boundary conditions) are of the same nature. We can then apply guidelines (Le Pochat et al., 2005) to know what the best alternative is for the designer between accuracy and effort spent.

As an example, for a product consuming energy within its use phase, then this phase will often be the most important phase (more than 80% of total life cycle impacts), and energy consumption has then such an importance that LC impacts can be directly derived from it (Kaebernick and Soriano, 2000).

Thus, from a designer perspective, the EcoDesign input for a light bulb or an electrical heat pump can be simplified to an amount of primary energy consumed and CO₂ emitted to produce the amount of final electrical energy the product will need, and the most suitable person for providing this data is the designer.

The boundary conditions are of high importance in the pre-assessment model choice. In this example, the difference between these two product boundary conditions will be on the use conditions of the products. For instance, if they were used in France, then we would consider that the light bulb would reject 80geqCO₂ (one of the criteria) for each kWh (the system input for the designer) of final energy it consumes and the heat pump will reject 180geqCO₂ for each kWh as it is used mostly in winter when electrical energy production is more pollutant (Clodic, 2009; Bouchereau, 2009). The purpose of pre-assessment is to get the designer to these standard values without going for a whole re-assessment of the electrical energy production system.

3.4 *Technical centre support*

Technical centres generally possess adapted solutions for companies willing to take the path of EcoDesign (Bensafi et al., 2005). The reason is that they treat close family products, and within a product class it is possible to choose relevantly between simplification hypothesis, tools and indicators (AFNOR, 2009).

Moreover, if no solution was searched before, this becomes an opportunity for bilateral improvement of knowledge base (ADEME, 2007). Technical centres may then release simplified tools usable by companies even if they do not benefit from an environmental expertise. As explained, these simplifications could be (Bensafi et al., 2005):

- Hypothesis, to avoid complex calculations or measures that have a reduced effect on the final result.
- Pre-assessment realised for clearly specified boundary conditions thanks to referenced LCA methods.
- Restrictions in material classes considered, to simplify material impact assessment in the production phase.
- Restriction in indicators analysed, to compute and display only the most significant impacts.

This work with the technical centres can be justified, in addition to what has been explained before, by the fact that they are the embodiment of all the different

stakeholders of a product and for instance in France, they are involved in the National Strategy for Sustainable Development (Le Pochat et al., 2005).

4 Method

4.1 Focus on the designed system

If the previous hypotheses are applied together, than the designer chose the adapted strategy (first hypothesis), built a flow diagram chart (second hypothesis) that will be used in further developments, found and applied the correct pre-assessment elements to the system boundaries. The designer (or the project team) is then able to see what will be the environmental impacts of each choice in product design.

4.2 The proposed model

The model (Figure 1) is derived from a conventional product design process.

Figure 1 Model proposed

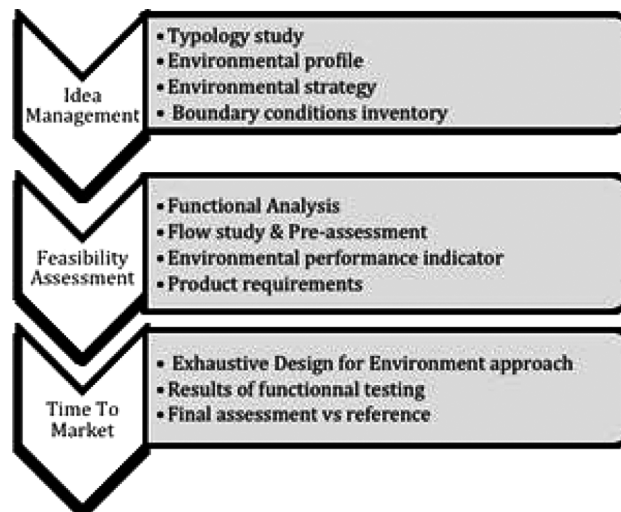

Product typology is applied to release a product profile and set an environmental strategy. For instance, this can be done thanks to:

- previous studies, which could be found during an analysis of the existing products (industrial state-of-the-art)
- guidelines on product typology (Bensafi et al., 2005)
- norms guiding for project teams towards an environmental profile (AFNOR, 2009).

Once product typology and environmental profile are settled, it is possible to choose an environmental strategy and select the impacts and product phases it is relevant to focus on.

The second step is to perform a FA to deliver product requirements. Once completed, the most important phases must be described thanks to a flow diagram in which pre-assessments are to be integrated on system boundary.

This representation is then a basis for component selection and first theoretical environmental assessments (without physical prototype testing).

Eventually, if the overall technical feasibility is confirmed (thanks to a first feasibility sample) and if market requirements are met, the rollout of Design for Environment guidelines and the detailed design of the product are possible. The next samples may then be tested and compared if a reference product or standard assessment exists.

5 Case study: innovative heating appliance design

Let us see how this approach can be derived to the EcoDesign of a new and innovative heating appliance within Robert Bosch Company (Trela et al., 2010). The aim is to design a new product ensuring higher end customer benefits than competitors. Market acceptance is required as market success is part of the definition of an innovation (Schumpeter, 1939).

Bosch Thermotechnology is the world leader in heating appliances industry. This division sells boilers, water heaters, regulation systems, renewable energy-based appliances, ventilation units, accessories and control devices. In 2009, the division recorded 2.87 billion € of sales and dedicated 3.2% of it in R&D budget.

A recent study on the impacts of the different activities within the company (including for instance plant energy consumption, logistics and workers travelling) showed that more than 98% of the equivalent CO₂ emissions came from the products sold in the market. This is why the DfEDfE approach is critical to achieve a reduction of the environmental impact of the whole company.

Finding the idea for the product will not be detailed here. It is assumed that we already have an idea to investigate. For our example, a hybrid-heating appliance is considered. It would be built with two subsystems, an electrical heat pump and a gas boiler, in a compact casing. The idea is, depending on external conditions (such as air temperature, energy and ecological cost) to provide heat with the lowest impact possible using the heat pump alone, the gas boiler alone or both subsystems.

5.1 Idea management

The product considered will be consuming energy (electricity and natural gas) during a long use phase (at least 15 years). Therefore, the use phase and the efficiency of the appliance will be the most important elements to consider, this environmental profile characteristic can be derived in our example from:

- Typology study (Kaebernick and Soriano, 2000)
- EcoDesign guidelines (AFNOR, 2009)
- Published LCA (Bensafi et al., 2005)

Typology study consists in the linkage of a product to a given environmental profile thanks to criteria, such as the product use phase length or its composition (Kaebernick and Soriano, 2000). The interest in such an approach is to get a profile for a product that

Integration of EcoDesign in the early steps of the innovation process

has not been studied yet and link it to others with similar environmental profiles. However, the drawback is that the hierarchy between main impacts is not easily established.

Even if EcoDesign guidelines are also based on typology, the issue of environmental impacts hierarchy is partially solved thanks to an algorithm enabling to build quickly a full environmental profile. One particular interest of these guidelines is that their efficiency is based on teamwork as product knowledge is involved from different aspects, such as product use, material composition, transportation and even legal status. This approach could for instance be brought in project team kick-off. For our example, the EcoDesign guideline (AFNOR, 2009) was assessed and its results, displayed in the Figure 2 can be compared with one of the LCA published on the closest existing appliance.

Figure 2 Product profile (see online version for colours)

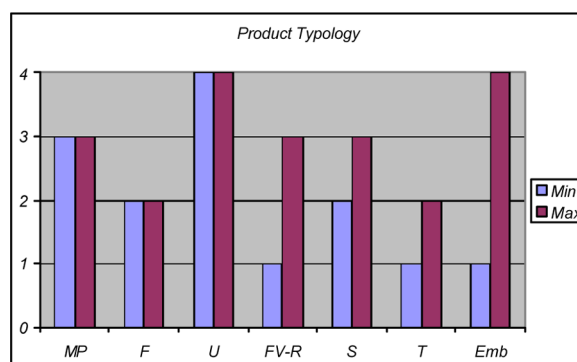

MP: Raw materials usage; F: Manufacturing; U: Use phase;
FV-R: End of life – Recycling; S: Substances; T: Transportation; Emb: Packaging.

Source: AFNOR (2009)

Two environmental profiles are displayed in Figure 2, the differences between ‘Min’ and ‘Max’ profiles are owing to a few different hypotheses regarding the product characteristics, which are not fixed yet in this early stage of the development. In our example, we can however, see that whatever the first hypotheses are, the use phase of the product will be the most critical and should be in our focus.

As more and more product LCAs using referenced methods can be found, they must also be considered in the scope of the research and results should be integrated. The purpose is not to set the perfect environmental profile, as a new product profile would be different, but take the best environmental strategy on the earliest product design stages.

In our case, an example can be found within a study from the CETIAT (Bensafi et al., 2005), which is a French technical centre dedicated to heating industries. As explained earlier, this kind of structure is one of the best suited for providing environmental profiles, as they are, most of the time, working with similar product ranges. Figure 3 shows the environmental profile of a gas boiler according to the CETIAT. For each considered environmental indicator, the impact of the manufacturing phase (in red, including material and energy consumption involved in the whole process), the use phase (in green, including the gas consumption), and the end of life phase (in yellow) are displayed. This study, which was conducted on a boiler similar to the one integrated in

the hybrid product, shows that once again most of the impacts (except the solid-waste impact) of the appliance will come its energy consumption within its use phase. The point is that if we want to consider the most frequently used indicators, greenhouse effect and energy resources, no significant improvement can be made by working on any other phase than the use phase. Thus focus must be on the energy consumption of the appliance and its overall efficiency.

Figure 3 Environmental impacts (EI95) of a gas boiler (see online version for colours)

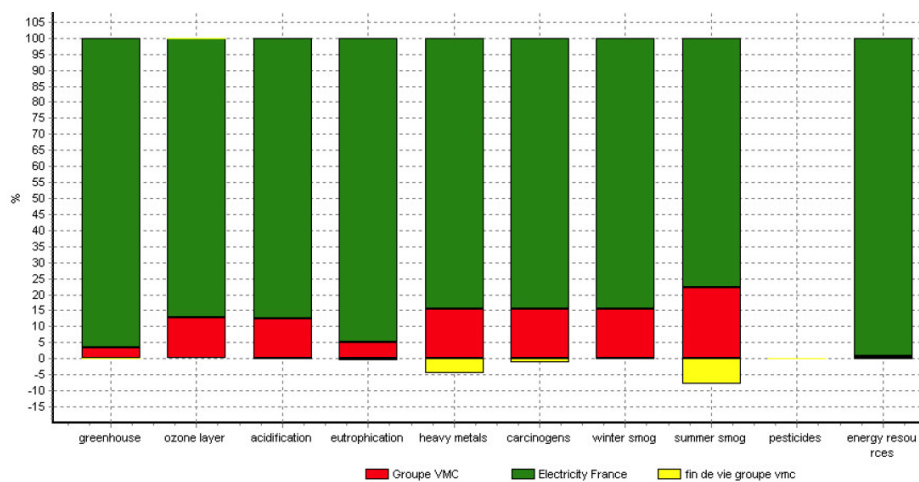

Source: Bensafi et al. (2005)

For our particular application, it was shown that the use phase was the most important regarding environmental impacts, mainly because of the high-energy consumption. However, the behaviour of the appliance, and thus the device efficiency, will depend on the ‘boundary conditions’ of the system (such as weather type, convectors efficiency and energy prices) and the control strategy applied within the use phase, which are depending on the market considered for the appliance (country, house type ...).

That is owing to the sensitivity of the heat pump to the heat source temperature (for instance outside air) and to the sink source (central heating water). In comparison, the gas boiler sensitivity is lower. As a consequence, the device efficiency will then be different for each market as the outside air temperature is depending on the climate and as central heating circuit temperature is depending on the country and building type.

Getting data about the boundary conditions is the first step and is investigated with the support of other stakeholders (such as energy providers for instance).

Therefore, we can notice that there is a gap between the appliance designer and the environmental expert, resulting in communication difficulties. The interface between these two actors can be realised thanks to the pre-assessments.

To complete the Idea Management phase, it is then required to provide an environmental profile for the product and build a strategy to bring a new product with the lowest impact possible on the environment. In our example, it is considered as a priority to reduce the consumption of primary energy and CO₂ emissions within the use phase thanks to product architecture, component selection and system command. The result would then be a good balance between gas and electricity consumption, with a reduced

Integration of EcoDesign in the early steps of the innovation process

overall primary energy consumption and overall CO₂ emissions in comparison with the latest comparable appliance. We would also be able to see which markets could be selected for the selling of this appliance.

5.2 Feasibility analysis

Once product typology established, a FA was performed to provide product requirements. This FA is conducted for each phases of the product life cycle. However, most of the effort was spent on the most critical phase, which was, as identified thanks to product typology, the use phase.

Figure 4 shows a simplified flow diagram for the product. This first level must be detailed to bring the designer to component and architecture selection.

Figure 4 First level of the flow diagram (see online version for colours)

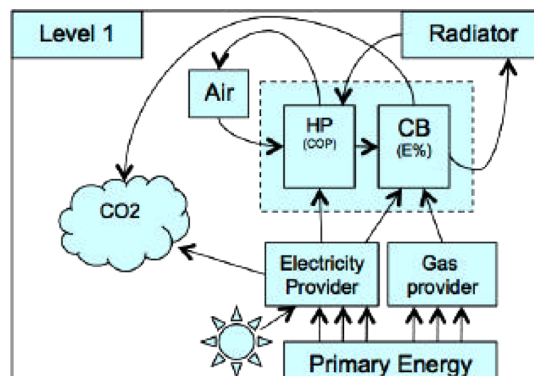

HP : Heat-Pump; CB : Condensing gas boiler.

As it was shown that the focus had to be on the primary energy consumption and the greenhouse effect, we should then detail the system behaviour to assess its efficiency and its energy (gas and electricity) consumption. While the designer can work on the second level of the system (Figure 5), the environmental expertise consists in selecting the right pre-assessments.

Figure 5 Second level of the flow diagram (see online version for colours)

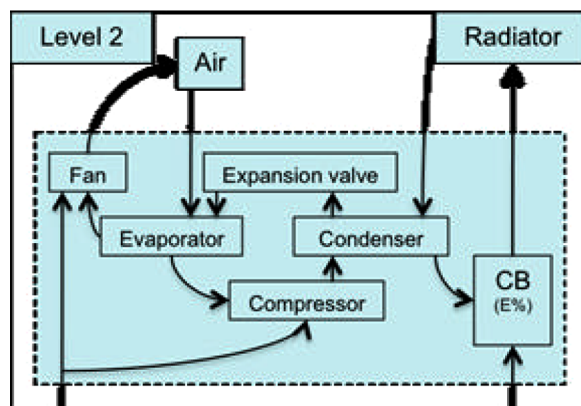

If we consider the electricity consumption for instance, the hypotheses are critical. The market (country) considered will have a great effect and also the computation method for the LCA is important. The Figure 6 displayed an example for the pre-assessment to be considered for electricity on the French market regarding a heating appliance. As this kind of product is consuming electricity in the cold period of the year, the CO₂ emissions per electrical kWh are higher than for a lamp for instance. This is owing to the fact that nuclear power plants produce French electricity as a basis but in winter other types of energy plants have to be used to answer the demand, thus increasing the CO₂ emissions of the heating appliance.

Figure 6 Example of pre-assessment

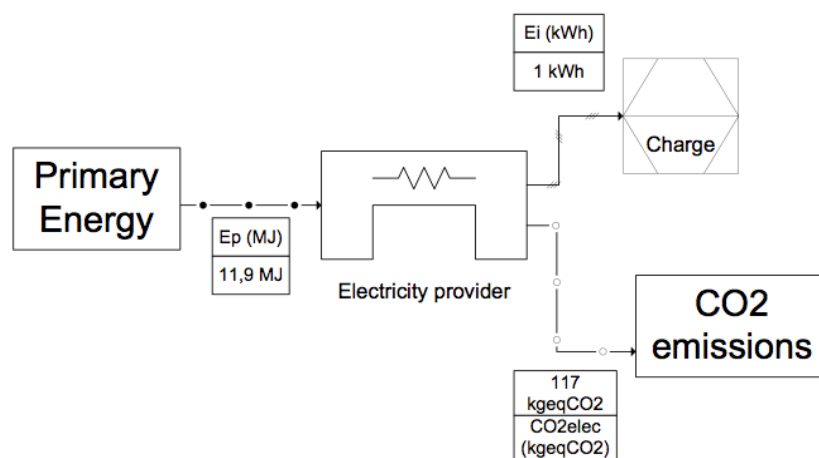

The same pre-assessment can be realised for the gas consumption even though the difference is that its impact has to be considered both before the delivery to the customer's (mainly energy resources) and after its combustion (CO₂ emissions).

Thanks to this approach, we were able to assess different architecture solutions and after different components alternatives (with different transfer functions).

The use of flow diagram charts enables communication with different stakeholders as the system can be seen as a black box.

For instance it is possible to make a static view of the product to explain to the end customer what his interest in the solution would be against the latest competitive available solutions.

The end customer advantages may then be given in quantitative terms, as well as the impact on the environment.

It is also a good vector for communication towards decision makers and stakeholders, showing links that might not have been clearly understood before and get a systemic point of view.

The purpose of the feasibility investigation in our example was to proceed to component, architecture selection and control strategy to provide, for the considered markets, the product with the smallest environmental impact (CO₂ equivalent emissions and Primary Energy consumption).

5.3 Time to market

Within the Time To Market process, it is then required to bring the product to the best achievable quality level, using methods, such as FMEA, in which the different level decomposition of the FA is a great input.

The formalism adopted during the flow diagram construction can be used as a base for computation and dynamic model creation. That is to say that transfer functions are now closer to real dynamic behaviour of the system (Figure 6).

This computation was done in our example and served as an input for control algorithms and specifications of the product.

As the entire product characteristics must be defined and as the maturity is now high enough, standard Design for Environment guidelines can be considered and applied. For instance, product life phases that were not identified as critical in the environment profile construction must be integrated.

Our approach is proposed as a practice and in our case; final validation is done thanks to European policy on Energy using Products (Kemna et al., 2007) and its derived calculation model for environmental labelling of products. It is indeed very important to have a common neutral and objective calculation model to ensure that there were no impact movement out of the designer scope and that the final solution reaches the goals set as market specifications.

Furthermore, our project became, during the Time To Market phase a pilot project for new Design for Environment guidelines application. For instance, special attention was given to the selection of materials in the new components to comply to the Bosch standards taking into account directives such as Registration, Evaluation and Authorisation of Chemicals (REACH), Reduction of Hazardous Substances (RoHS) and the Battery Directive. Another important aspect, that could not have been studied earlier, was the recyclability rate of the appliance, based on the material selection for components and their own recyclability.

6 Discussion

This step-by-step approach enabled to deal with major issues and choices (later implying the greatest environmental impacts) in the early stages of the project. We were also able to comply with both relevance and feasibility of the study of these first aspects (for instance overall efficiency and architecture selection). This early concerns, considered before freeze of product specifications lead to consider the boundary conditions of the product (house type, radiator characteristics, weather data and energy prices) as key variables for market selection and thus supported marketing activities.

Once product specification settled and detailed design started, we were then able to start longer and more extensive processes, such as the declaration of substances for new parts, requiring a precise knowledge of the new parts to be used and advanced exchange with the selected suppliers to track these substances.

Even though this approach is specified for innovative product design it still has some drawbacks that should be noticed. As it is based on the available pre-assessments, the designer must then have a good confidence in the source of this data, which might not always be obvious to find, or update.

The designer must also have a systemic look on the product and understand the basics of the energetic concepts summoned to provide the relevant data from the designed system to the boundary conditions.

The next steps on this topic could be to provide a database for the most used pre-assessments, under given boundary conditions, and done thanks to referenced methods.

7 Conclusion

This paper showed with an example, which kinds of issues are met within the early stages of the EcoDesign of an innovative product.

These new situations will occur more and more often, and thus processes and tools have to be adapted to tackle them efficiently.

An approach was proposed to help the designer in accordance to the EcoDesign principles, including three hypotheses: the early strategic decision based on product typology, the flow study and the pre-assessments. The main interest is to proceed quickly with the most important impacts and gather all the environmental expertise within a few pre-assessment models. This was illustrated with the EcoDesign of a hybrid-heating appliance developed within Robert Bosch Company, which is deeply committed to the environment protection. Responsibility is a key value inspired by its founder and thus social and environmental responsibilities have to be demonstrated. Moreover, Franz Fehrenbach, the current chairman was awarded Eco-manager of the year 2006 by the environmental foundation WWF Germany and ‘Capital’ for its commitment, and in 2009 the ADAC ‘Gelber Engel’ price recognising the ecologically oriented innovative strength. Last but not least, Bosch is also a member of the World Business Council for Sustainable Development (WBCSD).

References

- ADEME (2007) *La recherche en éco-conception: Bilan très positif de l'appel à projets de 2004*, Press release, Relations presse ADEME – H&B Communication.
- Association Française de Normalisation (1997) *Norm NF EN ISO 14040, Environmental Management, Life Cycle Assessment*, Principles and Framework (AFNOR, Ed.)
- Association Française de Normalisation (2009) *Norm XP E 01-005, Produits mécaniques, Méthodologie d'éco-conception* (AFNOR, Ed.)
- Bakker, C. (1995) *Environmental Information for Industrial Designers*, PhD Thesis, University of Technology, Delft, The Netherlands.
- Bauer, D., Bourgeois, R. and Jakubowicz, M. (2008) *Mémotech. Sciences de l'ingénieur*, Casteilla, Paris.
- Bensafi, A., Richard, L. and Durier, F. (2005) *PRESSAT : un outil simplifié pour l'évaluation du profil environnemental d'appareils de chauffage, ventilation et climatisation*, CETIAT.
- Bouchereau, J-M. (2009) *Contenus en CO2 des différentes énergies*, Séminaire PREBAT, <http://www.chantier.net/documents/014Bouchereau.pdf>
- Clodic, D. (2009) *Les équipements actuels : leurs performances, leurs limites, leurs évolutions à venir*, Séminaire PREBAT, <http://www.chantier.net/documents/004Clodic.pdf>
- Conrad Luttrupp, J.L. (2005) EcoDesign and The Ten Golden Rules: generic advice for merging environmental aspects into product development.

Integration of EcoDesign in the early steps of the innovation process

- Grisel, L. and Duranthon, G. (2001) *Pratiquer l'éco-conception*, Association Française de Normalisation (AFNOR).
- Janin, M. (2000) *Démarche d'éco-conception en entreprise. Un enjeu : construire la cohérence entre outils et processus*, PhD Thesis, Chambéry, France.
- Kaebnick, H. and Soriano, V. (2000) 'An approach to simplified environmental assessment by classification of products', *7th CIRP International Seminar on LCE*. Tokyo.
- Kemna, R., van Elburg, M., Li, W. and van Holsteijn, R. (2007) *Eco-design of CH-Boilers*, Delft, VHK.
- Kobayashi, H. (2006) 'A systematic approach to eco-innovative product design based on life cycle planning', *Advanced Engineering Informatics*, Elsevier, Vol. 20, pp.113–125.
- Le Pochat, S., Bertoluci, G., and Froelich, D. (2005) 'Integrating ecodesign by conducting changes in SMEs', *Journal of Cleaner Production*, Vol. 15, No. 7, pp.671–680.
- Millennium Ecosystem Assessment (2005) *Millennium Ecosystem Assessment Synthesis Report*, Pre-publication Final Draft Approved by MA Board on 23 March.
- Ministère de l'écologie, de l'énergie, du développement durable et de l'aménagement du territoire (2008) *Programme Travail PREBAT, 2007-2012*, http://rp.urbanisme.equipement.gouv.fr/puca/edito/Prebat2007_2012.pdf
- Reine Karlsson, C.L. (2005) 'EcoDesign: what's happening? An overview of the subject area of EcoDesign and of the papers in this special issue', *Journal of Cleaner Production*, Vol. 14.
- Samet, W., Ledoux, Y. and Nadeau, J-P. (2009) *Evolution des outils MAL'IN vers l'éco-innovation*, 11ème Colloque National AIP PRIMECA.
- Schumpeter, J.A. (1939) *Business Cycles: A Theoretical, Historical and Statistical Analysis of the Capitalist Process*, Two vols., McGraw Hill Book Co., New York, pp.xvi, 1095.
- Trela, M., Gay, A. and Bimont, C. (2010) *Installation de chauffage et/ou de fourniture d'eau chaude sanitaire*, Patent No. FR 2 947 896, Robert BOSCH GMBH.