



Science Arts & Métiers (SAM)

is an open access repository that collects the work of Arts et Métiers ParisTech researchers and makes it freely available over the web where possible.

This is an author-deposited version published in: <http://sam.ensam.eu>
Handle ID: <http://hdl.handle.net/10985/7542>

To cite this version :

Chuan HONG ZHOU, Benoît EYNARD, Lionel ROUCOULES - Interoperability Between PLM and RoHS Compliance Management Based on XML and Smart Client - Journal of Computing and Information Science in Engineering - Vol. 9, n°3, p.6p - 2009

Any correspondence concerning this service should be sent to the repository

Administrator : archiveouverte@ensam.eu

Interoperability Between PLM and RoHS Compliance Management Based on XML and Smart Client

Chuan Hong Zhou

Associate Professor
CIMS & Robot Center of Shanghai University,
Shanghai 200072, China
e-mail: chzhoushu@gmail.com

Benoît Eynard

Professor
Department of Mechanical Systems Engineering,
Université de Technologie de Compiègne,
BP 60319,
F.60203 Compiègne Cedex, France
e-mail: benoit.eynard@utc.fr

Lionel Roucoules

Professor
Laboratoire des Sciences de l'Information et des
Systèmes - UMR CNRS 6168,
Arts et Métiers Paris Tech,
Centre d'Aix en Provence 2,
cours des Arts et Métiers,
F.13617 Aix-en-Provence, France
e-mail: lionel.roucoules@ensam.eu

Nowadays, more and more companies are going to adapt themselves to restriction on the use of certain hazardous substances (RoHS) compliance and enforcement by leveraging product lifecycle management (PLM) technology. The paper presents a general framework that integrates the bill of material extensible markup language (XML) files from heterogeneous PLM systems to RoHS compliance management system. This framework is based on the use of Smart Client technology to obtain flexibility required for complex and distributed environments. It also makes use of XML technology and data structure to obtain reuse and robustness. [DOI: 10.1115/1.3184601]

Keywords: product lifecycle management, restriction on the use of certain hazardous substances, bill of material, extensible markup language, Smart Client

1 Introduction

Considering harmful effects of specific substances, it is necessary to reduce the amounts of waste generated by used and discarded products and to manage their end of life. So, laws have been made to limit the hazardous substances contained in products and restriction on the use of certain hazardous substances (RoHS) is widely adapted in electrical and electronic equipment [1,2]. RoHS aims at limiting the use of substances, such as lead, cadmium, and many other materials that are harmful to the environ-

ment. RoHS is also one of the rules forcing manufacturers to take more environmental responsibility. In China and Korea, similar laws and procedures have existed [3].

Managing detailed data on the material composition of each product component and part will become a critical subject. Companies will be forced to closely monitor the substances contained in each part. They will also have to consider additional changes from new legislation and from RoHS directive in other regions. Nevertheless, many manufacturers are still far from complying with RoHS issues, with collecting and managing the data efficiently still remaining as the biggest stakes. On the basis of investigation by leading consulting corporations, it is an important fact that collecting and managing components and materials data are proving to be the stumbling blocks for large manufacturers [4].

An overall RoHS compliance process [4–6] centered on materials databases is summarized in Fig. 1. First, original equipment manufacturers (OEMs) submit material data. The data must be validated and verified before storing in materials databases. The above process is named as RoHS compliance declaration. Second, the product bill of material (BOM) information needs to be extracted from BOM extensible markup language (XML) files of product lifecycle management (PLM) systems. The BOM information will connect with materials databases to extend and merge into a new BOM (compliance BOM), which includes parts, material, and substance (Fig. 4). Last, the analysis of the RoHS compliance can be based on life cycle assessment (LCA) and other related approach (for example, a stochastic optimization method [7]). The paper deals with a general framework that integrates the BOM XML files from heterogeneous PLM systems to RoHS compliance management system (Fig. 1, dashed rectangle), and does not address compliance analysis and RoHS compliance declaration.

PLM promises significant benefits to manufacturing industry and the market is full of vendors claiming to provide faster time-to-market for new products, reduced costs for product development and manufacture, increased revenue, better quality of products, enhanced product innovation, and other valuable benefits [6]. Because of the high appeal of these benefits and its associated return on investment (RoI), PLM has become one of the fastest growing categories of enterprise systems and applications. With intense global competition and increasing product complexity in manufacturing industry, companies are increasingly relying on collaborative PLM systems and information technology (IT) solutions to streamline product development and production processes [8]. RoHS compliance needs BOM data and other materials data, which are often distributed in heterogeneous information systems. There are so many PLM and similar systems used by manufacturers and their OEMs that it is difficult for them to collect and manage needed data for RoHS compliance.

Applications interoperability between PLM and RoHS compliance management based on XML and Smart Client has not been previously studied in literature. However, some methods to integrate with heterogeneous PLM systems and the selection of hazardous substance and recyclable content specifications for components have been discussed. Joshi and Dutta [7] presented a new approach for taking into account of regulatory requirements in the early design phase, with the aim of reducing downstream costs of compliance. By the way, XML is a very important role to support the creation, exchange, management, and archival of information about product, process, people, and services across the networked and extended enterprise covering the whole spectrum of product lifecycle. For example, most recent standard, such as Product Data Markup Language (PDML) and Electronic Business using eXtensible Markup Language (ebXML), are based on XML [9,10]. So several leaders of PLM industry vendors want to build their XML standard to get a competitive advantage in markets. There are other examples of XML applications, such as Siemens PLM (PLM XML) and Dassault Systèmes (3D XML). In the same way, other PLM vendors implement similar XML connectors in their

Contributed by the Engineering Informatics Committee of ASME for publication in the JOURNAL OF COMPUTING INFORMATION SCIENCE AND ENGINEERING. Manuscript received December 20, 2007; revised manuscript received November 27, 2008; published online September 2, 2009. Editor: S. Callahan.

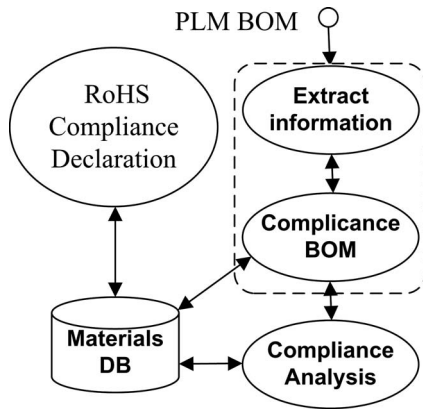

Fig. 1 RoHS compliance process

systems [11]. Moreover, concerning the study on RoHS compliance standard, IPC 1752 (Association Connecting Electronics Industries)¹ [12] is the standard for the exchange of materials declaration data, which capable of supporting XML. This standard is developed by a group of OEMs, emergency medical service (EMS) providers, component manufacturers, circuit board manufacturers, materials suppliers, information technology solution providers, and the National Institute of Standards and Technology. Using Adobe's Acrobat technology, IPC1752 allows creating a consistent format to transfer detailed specifications between the members of the global electronics supply chain. There is lack of adoption for several reasons. One of main reasons is that IPC1752 form still does not offer the flexibility needed by some OEMs [4].

This paper is organized as follows. In Sec. 2 we introduce an overview of the interoperability framework. It integrates the BOM XML files from heterogeneous PLM systems to RoHS compliance management system. The development of RoHS compliance management system based on Smart Client is detailed in Sec. 3. In Sec. 4 we present the specific scenario of the business case study, which integrates the BOM XML files from SmarTeam and Teamcenter Engineering to RoHS compliance management system. Finally, the main issues of the case studies will be summarized, and concluding remarks along with future research works are given in Sec. 5.

2 Interoperability Framework

The interoperability framework has a complex architecture illustrated in Fig. 2 (where numbers indicate the sequence of steps). These steps are explained below.

- (1) Publish the RoHS compliance Smart Client. Smart Client is a new technology used in software development, which will be discussed in Sec. 3. The IT administrator will publish a software package for the RoHS compliance Smart Client in his/her enterprise's website.
- (2) As users, compliance engineers download and install the RoHS compliance Smart Client, and then can run it.
- (3) The function "Extract information" concerns the definition of BOM XML file from PLM systems. As there are heterogeneous PLM systems, various BOM XML file formats are needed. The method presented is to settle this problem, which will be discussed in Sec. 3. After the RoHS compliance Smart Client extracts the product BOM data, it is necessary to build a new BOM through joining materials data from material database. This new BOM is named "Compliance BOM" and described in Sec. 3.

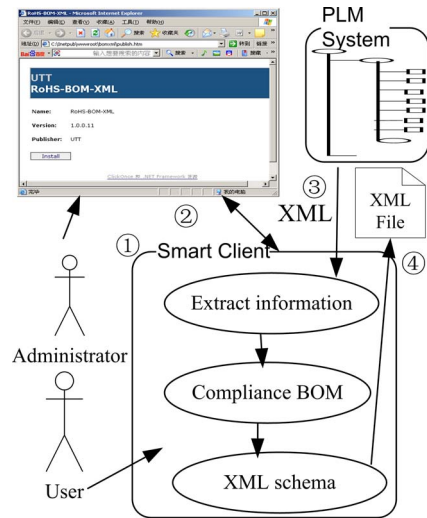

Fig. 2 Architecture of system interoperability framework

- (4) It is essential to export an XML file as a result for analyzing RoHS compliance. An XML Schema file is defined for the XML file and it will be detailed in Sec. 3.

3 Development of the Interoperability Framework

The management of RoHS compliance needs a kind of software technology, which has following characters. First, it must be easy to connect with internet materials databases, which often are distributed to different places. Second, it needs to provide the snappy look and feel inherent to desktop applications to analyze and display graphic results of RoHS compliance. Finally, it must be automated update in order to adapt to different RoHS-style environmental laws. Fortunately, Smart Client is a good solution for the above mentioned needs.

Smart Client is a new technology used in software development, generally referring to applications, which are delivered via the web, do not require installation (or provide automated installation and updates), automated update without user action, and have a graphic user interface of standard desktop applications [13]. Smart Client applications bridge the gap between web applications and desktop applications.

In order to develop a reusable and extendable Smart Client for RoHS compliance, C# was chosen to develop it. This language allows the easy decomposition of a program into modules dedicated to specific functions. Moreover, this kind of modular program can easily be re-used, updated, and improved if the output format has to be modified.

3.1 Extract Information From BOM XML Files of PLM Systems.

A bill of materials describes a product in terms of its assemblies, subassemblies, and basic parts. Basically consisting of a list of parts, a BOM is an essential reference of the design, manufacture, and maintenance of any product. RoHS compliance uses BOM and integrates the material's data.

At the moment, a lot of software systems, such as Teamcenter Engineering from Siemens PLM Software and SmarTeam from Dassault Systèmes are available with BOM XML output functionality. However, traditional BOM XML data are, in general, stored in proprietary data formats and constrained by heterogeneous software systems. Each of these systems has its own proprietary formats for saving BOM XML data as files [10].

Considering the BOM XML file is generally open, it is important to find key information. Analysis process of BOM tree is shown in Fig. 3. This figure gives an example for the BOM XML file from SmarTeam.

First, the relationship between parent and child items is impor-

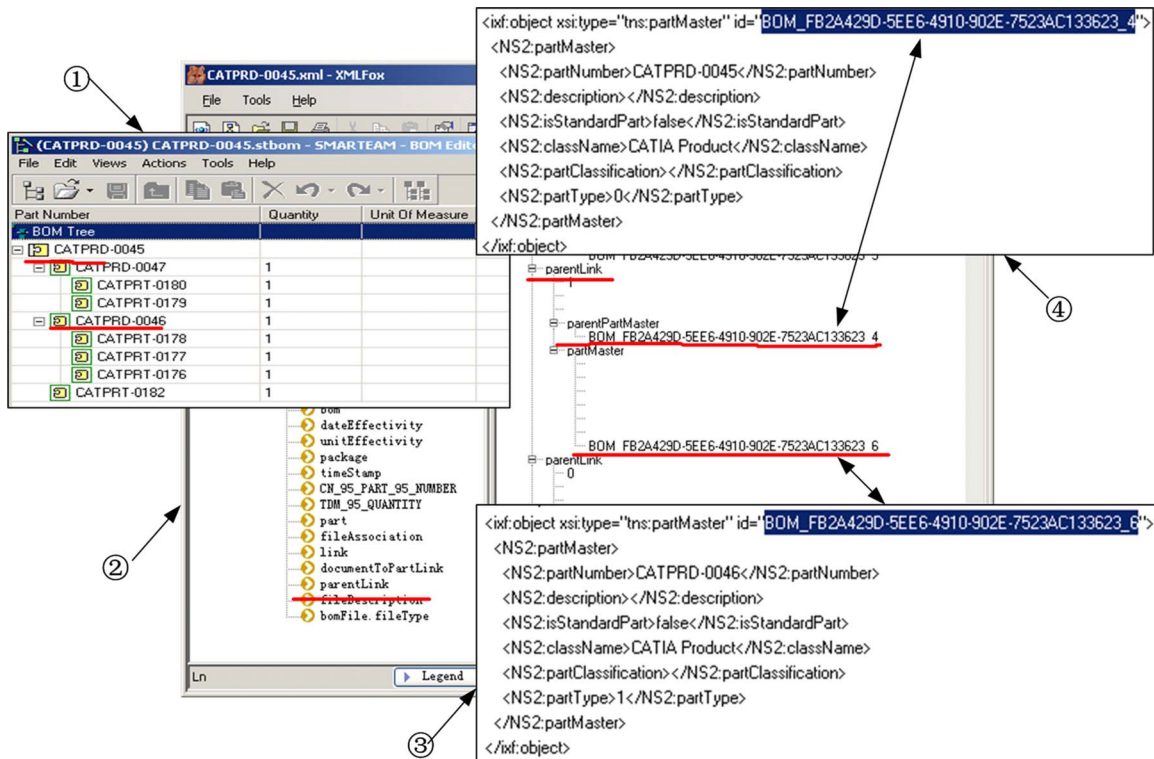

Fig. 3 Understanding the BOM XML file from SmarTeam

tant to understand the BOM XML file. As shown in Fig. 3 (①), parent item “CARPRD-0045” has several child items, which include child item “CARPRD-0046.” Second, there exists a very interesting XML Element “parentLink” (②), which includes two XML elements, “parentPartMaster” and “partMaster” with XML Attribute “href.” Lastly, using XML Attribute “href” corresponding “id,” it is easy to find parent item “CARPRD-0045” and child item “CARPRD-0046,” as shown in Fig. 3 (③,④). Other information linked to items can be captured from XML Element “partMaster.”

In the same way, the BOM XML file from Teamcenter Engineering has an important XML Element “Occurrence,” which includes two XML Element “id” and “parentRef.” It is easy to know that Occurrence is similar with the above-mentioned “parentLink.”

After the BOM information, which just includes parts information, is extracted from the BOM XML file, it will connect with materials’ databases to extend and merge into a new BOM (compliance BOM), which includes parts, material, and substance (Fig. 4). So there is no repetition of information.

3.2 Compliance BOM. Compliance BOM is composed of parts and material data, as shown in Fig. 4. First, the part layer is mainly based on BOM XML file from PLM systems; second, OEMs provide materials data for the material layer, which should be a homogenous material (a material that cannot be mechanically disjointed into different materials) [14]; finally, some professional institutions provide checking RoHS information for substance layer. So, compliance BOM is huge and more complex than the general engineering BOM.

In the field of computer science, a data structure is a way of storing data in a computer so that it can be used efficiently [15]. In Fig. 4, a terse “struct” type is designed to build data structure for “Treenode relationship” and “Attribute Column.” In order to adapt compliance BOM data structure to grow dynamically, “ArrayList” is chosen for the basic data structure. This data structure is automatically expanded to accommodate new objects if filled beyond

its current size, and also automatically recovers some of its unused space to save memory. On the other hand, class “Treenodecontent” combining “Hashtable” and ArrayList holds detail across a range of information for the Compliance BOM tree.

3.3 XML Schema Specification. Naturally, it is useful to save compliance BOM as an XML file, which can be imported into PLM systems as RoHS compliance results whenever the results of RoHS compliance can be browsed. Moreover, an XML schema [16] is a description of a type of XML document, typically expressed in terms of constraints on the structure and content of documents of that type, above and beyond the basic syntax constraints imposed by XML itself. So specifying a relevant XML schema is a key to create the Compliance BOM XML file.

Regarding established patterns of object-oriented programming in constructing XML schemas, the compliance BOM XML schema is specified based on such an approach and is enabled to implement a flexible architecture. This architecture ensures consistency throughout the system and helps to accommodate growth and changes. Figure 5 describes the main principle of object-oriented design, i.e., encapsulation.

4 Case Studies

A significant number of case studies were carried out in order to assess the efficiency of above interoperability framework that integrates the BOM XML files from heterogeneous PLM systems to RoHS compliance management system. The tests were based upon two BOM XML files (one from Teamcenter Engineering 2005 SR1, another from SmarTeam Editor V5R16) corresponding to a subassemble parts of cutter. Figure 6 shows the process during case studies.

The first step of the case studies was to import the BOM XML file (Fig. 6 (①)) and to display the RoHS compliance result in the main windows (②) of RoHS compliance Smart Client. For simplicity, the case studies have no RoHS compliance analysis process, and material composition and hazardous substance data are

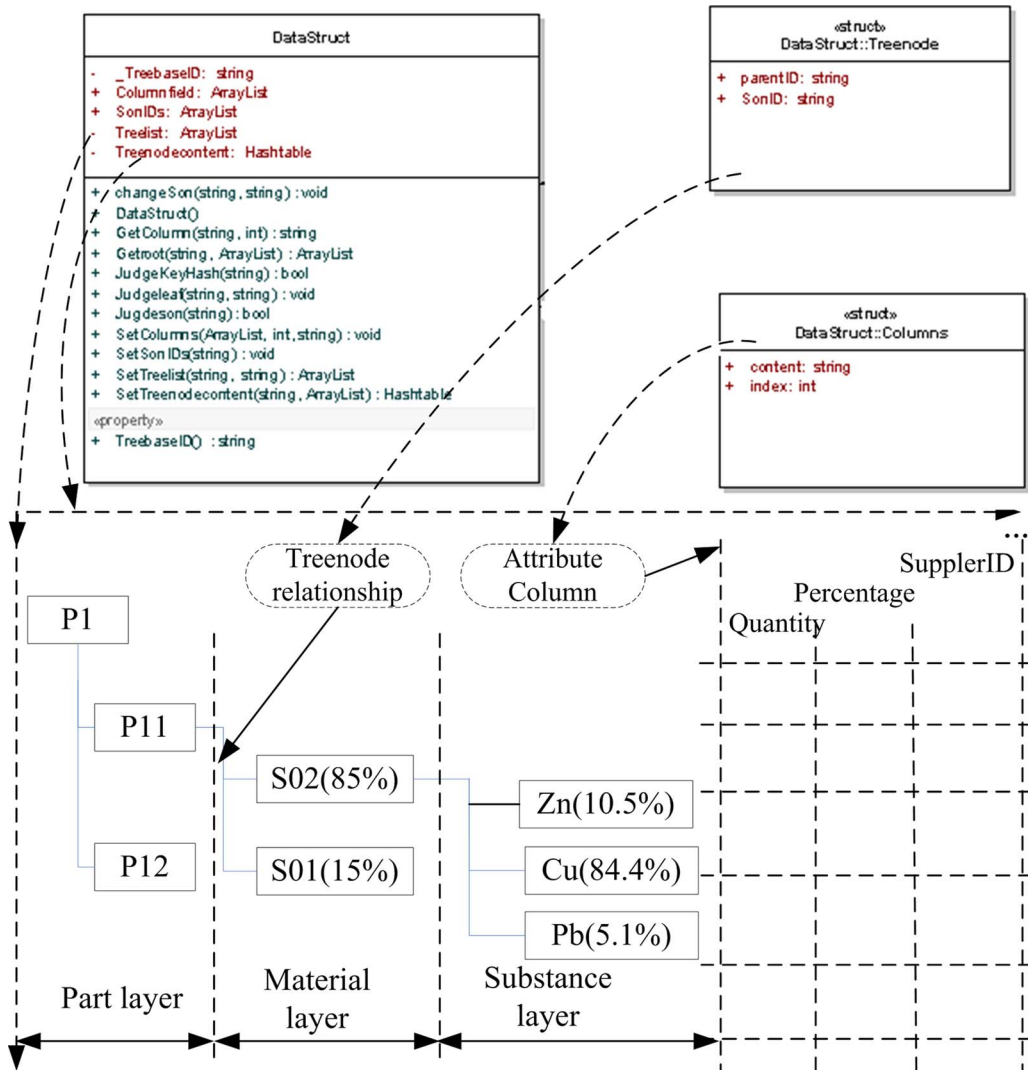

Fig. 4 Compliance BOM data structure

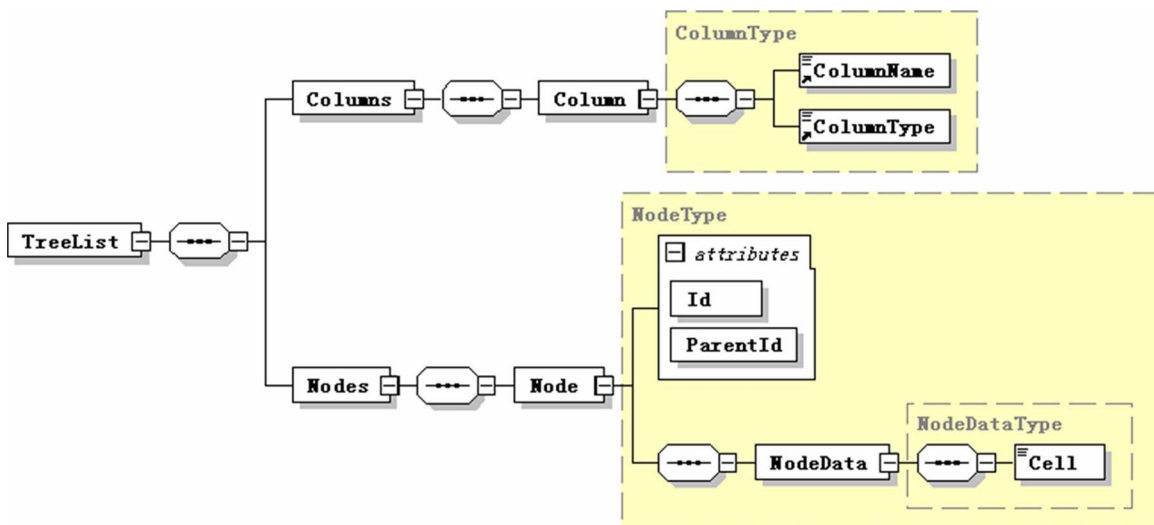

Fig. 5 XML schema model for the compliance BOM XML

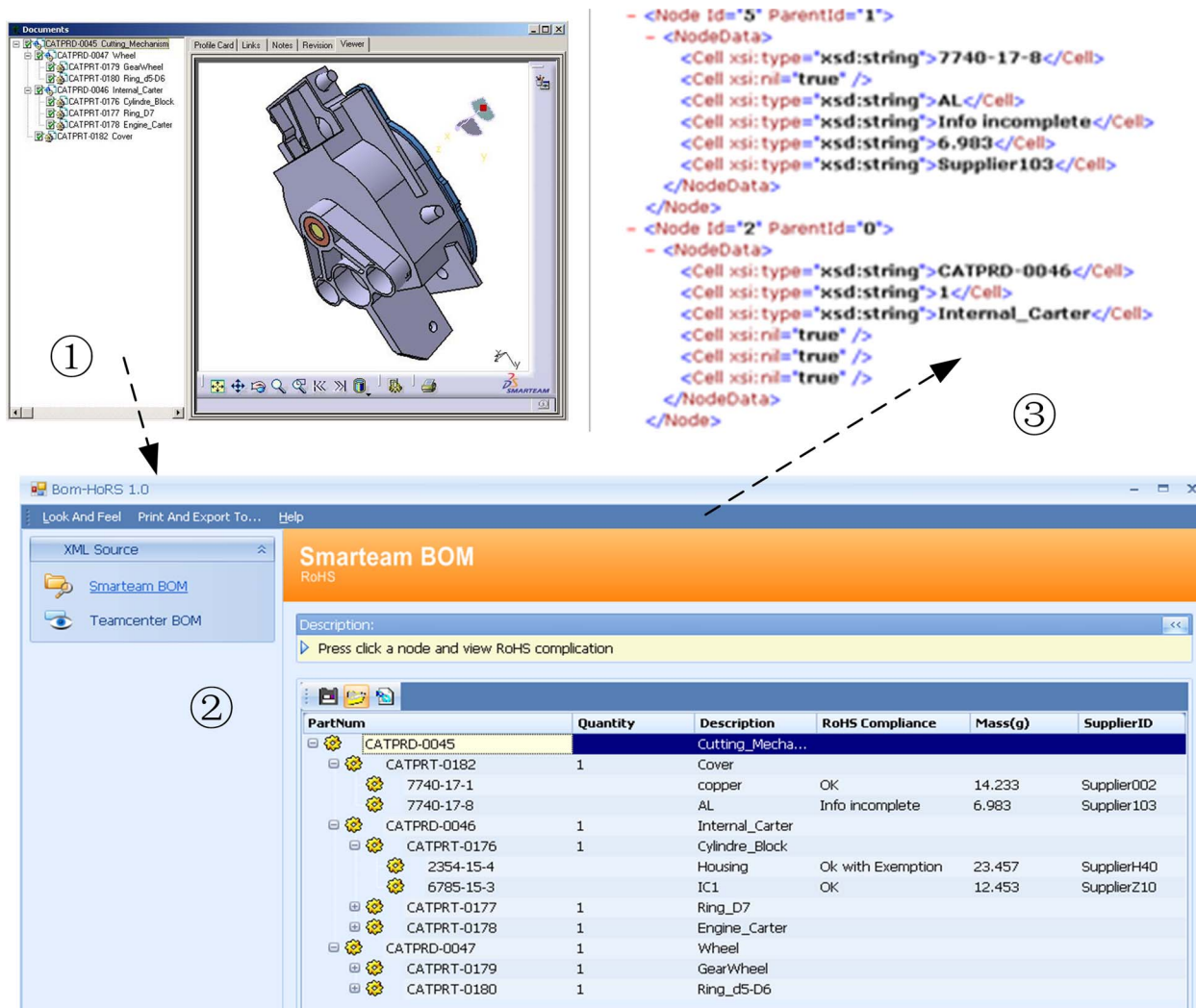

Fig. 6 Case studies process

stored in a textual encoding of the product data (ASCII) file. The following step was then to output the compliance BOM XML file in order to share with other systems (③).

As summary of results, it can be underlined that in these case studies, the interoperability framework that integrates the BOM XML files from heterogeneous PLM systems to RoHS compliance management system based on Smart Client and XML was to be addressed. The feasibility of the standardization of the data exchange, based on XML, was to be demonstrated. The development of RoHS compliance Smart Client to get BOM information from XML files (Teamcenter Engineering and SmarTeam) was to be tested. Moreover, this kind of interoperability framework can easily be re-used and improved if the application environments have to be modified.

5 Conclusion and Future Works

Over the past several years, manufacturers have faced an increasing array of new environmental mandates from jurisdictions such as the EU, China, Japan, and some states in the United States. The RoHS directive is famous in these environmental mandates. Many companies are going to adapt themselves to RoHS compliance enhanced by PLM technology. The paper has presented an interoperability framework based Smart Client and XML with the aim of using the recent advancements in PLM software capabilities to manage the data more efficiently in RoHS compliance.

The main conclusions are drawn as follows. This interoperability framework has the following characteristics.

- Smart Client makes this integration framework with both benefits of a rich client application and a thin client application.
- Making use of XML technology—the framework presented is not restricted to use BOM XML files from PLM systems, and can output XML files to share with other systems.
- Flexible application of object-oriented programming and data structure makes the framework obtain the property of reuse and robustness.

Future research works may focus on developing in a deepgoing way of interoperation between PLM system and RoHS compliance management system. It includes two aspects: to research material submitting process in order to get the material content for OEMs better and accurately; to improve the RoHS compliance process by LCA and other ecotechnology deployment.

Acknowledgment

The authors acknowledge the support from Department of Mechanical Engineering of Université de Technologie de Troyes, France. Certain commercial equipment, software, or materials are identified in this paper in order to facilitate understanding. Such identification does not imply recommendation or endorsement by

Department of Mechanical Engineering of Université de Technologie de Troyes, France. In addition, this research was jointly sponsored by Shanghai Leading Academic Discipline (Project No. Y0102).

References

- [1] Puttlitz, K., and Galyon, G., 2007, "Impact of the ROHS Directive on High-Performance Electronic Systems—Part I: Need for Lead Utilization in Exempt Systems," *J. Mater. Sci.: Mater. Electron.*, **18**(1–3), pp. 331–346.
- [2] Puttlitz, K., and Galyon, G., 2007, "Impact of the ROHS Directive on High-Performance Electronic Systems—Part II: Key Reliability Issues Preventing the Implementation of Lead-Free Solders," *J. Mater. Sci.: Mater. Electron.*, **18**(1–3), pp. 347–365.
- [3] Spiegel, R., 2006, "Each RoHS Law Is Different," http://www.designnews.com/article/13774-Each_RoHS_law_is_different.php.
- [4] Karofsky, E., 2006, "RoHS—the Data Collection Problem," <http://www.amrresearch.com/Content/View.asp?pmillid=19996>.
- [5] Image Asia Limited, 2005, "Gaining Competitive Advantage through WEEE/RoHS/ELV Regulatory Compliance," Matrixone Innovation Seminar 2005.
- [6] Rangan, R. M., Rohde, S. M., Peak, R., Chadha, B., and Bliznakov, P., 2005, "Streamlining Product Lifecycle Processes: A Survey of Product Lifecycle Management Implementations, Directions, and Challenges," *ASME J. Comput. Inf. Sci. Eng.*, **5**(3), pp. 227–237.
- [7] Joshi, N., and Dutta, D., 2006, "Towards Regulatory Compliance Through PLM," *Proceedings of the International Design Engineering Technical Conferences & Computers and Information in Engineering Conference, ASME DETC/CIE 2006*, Philadelphia, PA, Sept. 10–13.
- [8] ARC Advisory Group, 2001, *PLM Strategy, Key to Future Manufacturing Success*, Whitepaper.
- [9] Rachuri, S., Subrahmanian, E., Bouras, A., Fenves, S. J., Fofou, S., and Sriram, R. D., 2006, "The Role of Standards in Product Lifecycle Management Support," *Proceedings of the International Conference on Product Lifecycle Management, PLM'06*, Bangalore, India, July 10–12.
- [10] Peak, R., Lubell, J., Srinivasan, V., and Waterbury, S., 2004, "STEP, XML, and UML: Complementary Technologies," *ASME J. Comput. Inf. Sci. Eng.*, **4**(4), pp. 379–390.
- [11] Rowe, J., 2005, "3D XML Specifications and Player Available From Dassault Systemes," http://www10.mcadcafe.com/nbc/articles/view_weekly.php?section=Magazine&articleid=206754&printerfriendly=1.
- [12] Association Connecting Electronics Industries (IPC), IPC 1752 for Materials Declaration, http://members.ipc.org/committee/drafts/2-18_d_Materials_DeclarationRequest.asp.
- [13] Hill, D., Webster, B., Jezierski, E. A., Vasireddy, S., Al-Sabt, M., Wastell, B., Rasmusson, J., Gale, P., and Slater, P., 2004, "Smart Client Architecture and Design Guide," <http://msdn2.microsoft.com/en-us/library/ms998468.aspx>.
- [14] McGrady, T., 2006, "The EU RoHS Directive: Big Issues Linger: Requirements Are Not so Crystal Clear, Industry Observer Says," *Met. Finish.*, **104**(11), pp. 51–53.
- [15] Aho, A. V., Ullman, J. D., and Hopcroft, J. E., 1983, *Data Structures and Algorithms*, Addison-Wesley, Reading, MA, Chap. 1.
- [16] Madria, S. K., 2005, "XML Schema and Data Management," *Data Knowl. Eng.*, **52**(2), pp. 181–183.