



### **Science Arts & Métiers (SAM)**

is an open access repository that collects the work of Arts et Métiers Institute of Technology researchers and makes it freely available over the web where possible.

This is an author-deposited version published in: <https://sam.ensam.eu>  
Handle ID: <http://hdl.handle.net/10985/11178>

#### **To cite this version :**

Francis PRAUD, George CHATZIGEORGIOU, Yves CHEMISKY, Fodil MERAGHNI -  
Micromechanical modelling of viscoelastic-viscoplastic-damage behaviour for polyamide woven fabric composites under cyclic loading. - 2016

Any correspondence concerning this service should be sent to the repository

Administrator : [scienceouverte@ensam.eu](mailto:scienceouverte@ensam.eu)



# MICROMECHANICAL MODELLING OF VISCOELASTIC-VISCOPLASTIC-DAMAGE BEHAVIOUR FOR POLYAMIDE WOVEN FABRIC COMPOSITES UNDER CYCLIC LOADING

F. Praud<sup>1,2</sup>, G. Chatzigeorgiou<sup>1</sup>, Y. Chemisky<sup>1</sup>, F. Meraghni<sup>1</sup>

<sup>1</sup>Arts et Metiers ParisTech, LEM3-UMR 7239 CNRS, 4 rue Augustin Fresnel, 57078 Metz, France

<sup>2</sup>IRT Jules Verne, Chemin du Chafault, 44340 Bougenais, France

**Keywords:** periodic homogenization, constitutive laws, damage, viscoelasticity, viscoplasticity

## Abstract

In this paper, a micromechanics model, based on the periodic homogenization method, is utilized to study thermoplastic woven composites. The proposed approach accounts for the microstructure effects and the local behaviour of the matrix accounting for viscoelastic, viscoplastic and damage phenomena. The damage mechanisms occurring into the yarns are modelled through a hybrid micro-phenomenological constitutive law based on the Mori-Tanaka mean field theory. Finally, the model capabilities have been illustrated under both monotonic and oligocyclic loading conditions.

## 1. Introduction

Due to their highly dissipative aspect, thermoplastic based composites exhibit a complex behaviour when subjected to cyclic loading. In these materials, the microstructure plays a key role in the initiation and the evolution of damage mechanisms which interplay with the matrix viscous phenomena. In this context, the present work aims at developing an integrated multi-scale modelling of cyclic damage behaviour for thermoplastic woven composites.

Based on the works of [1], [2] and [3] a comprehensive methodology using the concept of periodic homogenization has been established to ensure the transition between macroscopic and mesoscopic scales. This framework allows simulating the non-linear behaviour of periodic media using the approach of the constraint drivers as proposed in [3]. From this point, a meta-model (a meta-model is a model resulting from the imbrication of sub-models) has been implemented using a finite element unit cell including each constituent of the composite (matrix and yarns). Then, this approach has been successfully extended to account for damage coupled to the viscoelasticity and viscoplasticity of the matrix. Moreover, the damage mechanisms occurring into the yarns have been modelled using a damage scheme based on the Mori-Tanaka mean field theory [4–7]. The capabilities of the approach are demonstrated through virtual experiments including off-axis monotonic tensile and cyclic shear tests.

## 2. Scale transition methodology

### 2.1. Theoretical framework and model formulation

A periodic medium, such as woven composites, can be defined by a unit cell. If the dimensions of the unit cell are small enough compared to the dimensions of the macroscopic medium, a scale separation

can be assumed and then two scales are considered: A macroscopic scale defined by the macroscopic (or global) coordinates denoted by  $\bar{\mathbf{x}}$  and a microscopic scale defined by the microscopic (or local) coordinates denoted by  $\mathbf{x}$ . The assumption of scale separation ( $\bar{\mathbf{x}} \gg \mathbf{x}$ ) allows to consider the unit cell as a macroscopic material point. Thus, at the macroscopic scale, the heterogeneous medium can be replaced by a equivalent homogeneous medium. The motions of any macroscopic and microscopic material point  $\bar{M}(\bar{\mathbf{x}})$  and  $M(\bar{\mathbf{x}}, \mathbf{x})$ , respectively, are governed by the macroscopic and microscopic equations given in Table 1.

Table 1: Macro-scale and micro-scale equations

Equations	Macro-scale $\forall \bar{\mathbf{x}} \in \bar{V}$	Micro-scale $\forall \bar{\mathbf{x}} \in \bar{V}, \forall \mathbf{x} \in V$
Equilibrium	$\mathbf{div}_{\bar{\mathbf{x}}}(\bar{\boldsymbol{\sigma}}) = 0$	$\mathbf{div}_{\mathbf{x}}(\boldsymbol{\sigma}) = 0$
Kinematics	$\bar{\boldsymbol{\varepsilon}} = \frac{1}{2}(\nabla_{\bar{\mathbf{x}}}(\bar{\mathbf{u}}) + \nabla_{\bar{\mathbf{x}}}^T(\bar{\mathbf{u}}))$	$\boldsymbol{\varepsilon} = \frac{1}{2}(\nabla_{\mathbf{x}}(\mathbf{u}) + \nabla_{\mathbf{x}}^T(\mathbf{u}))$
Constitutive law	$\bar{\boldsymbol{\sigma}} = \bar{\mathbf{F}}(\bar{\boldsymbol{\varepsilon}})$	$\boldsymbol{\sigma} = \mathbf{F}(\mathbf{x}, \boldsymbol{\varepsilon})$
Energy	$\bar{W} = \bar{\boldsymbol{\sigma}} : \bar{\boldsymbol{\varepsilon}}$	$W = \boldsymbol{\sigma} : \boldsymbol{\varepsilon}$

In Table 1,  $\mathbf{div}_{\bar{\mathbf{x}}}$  and  $\mathbf{div}_{\mathbf{x}}$  denote the global and local divergences, while  $\nabla_{\bar{\mathbf{x}}}$  and  $\nabla_{\mathbf{x}}$  are the global and local gradients respectively. The homogenization step consists in defining the global constitutive behaviour through the operator  $\bar{\mathbf{F}}$  from the known local behaviours defined by the operator  $\mathbf{F}$  (that may be non-linear and rate dependent). To do so, a connection between scales is required. From the divergence theorem, it can be shown that the stress and strain averages within a unit cell are equal to stress and strain applied on its boundaries, which are considered as the macroscopic strain and stress respectively. Then, the connection between scales is ensured by the following equations:

$$\bar{\boldsymbol{\sigma}}(\bar{\mathbf{x}}, t) = \frac{1}{V} \int_V \boldsymbol{\sigma}(\bar{\mathbf{x}}, \mathbf{x}, t) dV = \frac{1}{V} \int_{\partial V} \boldsymbol{\sigma}(\bar{\mathbf{x}}, \mathbf{x}, t) \cdot \mathbf{n} \otimes \mathbf{x} dS, \quad (1)$$

$$\bar{\boldsymbol{\varepsilon}}(\bar{\mathbf{x}}, t) = \frac{1}{V} \int_V \boldsymbol{\varepsilon}(\bar{\mathbf{x}}, \mathbf{x}, t) dV = \frac{1}{2V} \int_{\partial V} (\mathbf{u}(\bar{\mathbf{x}}, \mathbf{x}, t) \otimes \mathbf{n} + \mathbf{n} \otimes \mathbf{u}(\bar{\mathbf{x}}, \mathbf{x}, t)) dS. \quad (2)$$

The assumption of periodicity implies that, within the unit cell, the displacement vector  $\mathbf{u}$  of any microscopic material point  $M(\bar{\mathbf{x}}, \mathbf{x})$  can be written under the form of an affine part on which a periodic fluctuation  $\mathbf{u}'$  is added:

$$\mathbf{u}(\bar{\mathbf{x}}, \mathbf{x}, t) = \bar{\boldsymbol{\varepsilon}}(\bar{\mathbf{x}}, t) \cdot \mathbf{x} + \mathbf{u}'(\bar{\mathbf{x}}, \mathbf{x}, t). \quad (3)$$

As the fluctuating part of the displacement  $\mathbf{u}'$  is periodic, it takes the same value on each opposite side of the unit cell. Also, the strain average (within the unit cell) produced by  $\mathbf{u}'$  is null. Therefore, the total strain average is well equal to the macroscopic strain as mentioned in (2). By introducing the conditions of periodicity (3) into the the micro-scale equations (given in Table 1) and considering the connection between scales (1), the relationship between the macroscopic stress and strain (operator  $\bar{\mathbf{F}}$ ) can be defined for any macroscopic material point  $\bar{\mathbf{x}}$ .

## 2.2. Numerical implementation

From a computational point of view, considering a cubic Finite Element unit cell, the aim of the proposed method is to apply a macroscopic strain on the unit cell by expressing the equality of the fluctuating

displacement field  $\mathbf{u}'$  on each pair of opposite border nodes (denoted by the indices  $i$  and  $j$ ):

$$\mathbf{u}'_i = \mathbf{u}'_j \quad \Leftrightarrow \quad \mathbf{u}_i - \mathbf{u}_j = \bar{\boldsymbol{\varepsilon}} \cdot (\mathbf{x}_i - \mathbf{x}_j). \quad (4)$$

The six components of the macroscopic strain tensor  $\bar{\boldsymbol{\varepsilon}}$  are introduced as additional degrees of freedom that are connected to the mesh of the unit cell using kinematic equations derived from (4). Then, these degrees of freedom are used as constraint drivers. Using this formalism, it can be shown that the dual forces on the constraint drivers can be directly linked to the corresponding components of the macroscopic stress tensor  $\bar{\boldsymbol{\sigma}}$ .

### 3. Definition of the unit cell

The studied material is a 2.2 twill weave glass fibre reinforced PA6.6 composite (Figure 1a). The unit cell has been modelled (Figure 1b) and periodically meshed using the open source software TexGen, developed at the University of Nottingham [8].

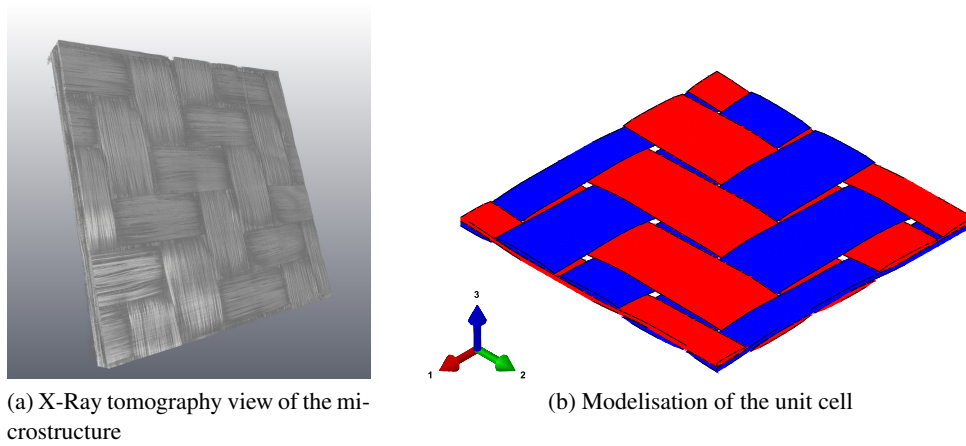

Figure 1: 2.2 twill weave pattern

The yarns are composed of numerous fibres unidirectionally oriented. From a modelling point of view, the yarns are considered to behave as an equivalent material that is anisotropic. Consequently, their mechanical behaviour depends on a certain orientation that is to be defined for each yarn separately. This orientation follows the middle line of the yarns.

### 4. Local constitutive laws

Using the previously described framework in Section 2, a meta-model can be established knowing the local constitutive laws of each phase of the microstructure (matrix and yarns).

#### 4.1. Constitutive laws of the matrix

Semi crystalline polymers such as PA66 are well known to exhibit a highly dissipative behaviour combining both solid and fluid properties (making them rate dependent) coupled to damage mechanisms (loss of apparent stiffness). To model such mechanical behaviour, it is proposed to consider a thermodynamically based constitutive law coupling viscoelasticity, viscoplasticity and ductile damage founded on the principle of effective stress [9, 10], as represented in the rheological scheme of Figure 2. The state laws

of the proposed model are defined by the following form of the Helmholtz free energy:

$$\rho\psi(\boldsymbol{\varepsilon}, \boldsymbol{\varepsilon}_v, \boldsymbol{\varepsilon}_p, r, D) = \frac{1}{2}(\boldsymbol{\varepsilon} - \boldsymbol{\varepsilon}_v - \boldsymbol{\varepsilon}_p) : (1 - D)\mathbb{C}_e : (\boldsymbol{\varepsilon} - \boldsymbol{\varepsilon}_v - \boldsymbol{\varepsilon}_p) + \frac{1}{2}\boldsymbol{\varepsilon}_v : (1 - D)\mathbb{C}_v : \boldsymbol{\varepsilon}_v + \int_0^r R(\xi)d\xi, \quad (5)$$

where  $\mathbb{C}_e$  and  $\mathbb{C}_v$  are fourth order stiffness tensors (classically defined for bulk isotropic media) while the internal state variables  $\boldsymbol{\varepsilon}_v$ ,  $\boldsymbol{\varepsilon}_p$ ,  $r$  and  $D$  respectively denote a recoverable viscoelastic strain, an irrecoverable viscoplastic strain, the isotropic hardening and the damage variable. Respectively to the

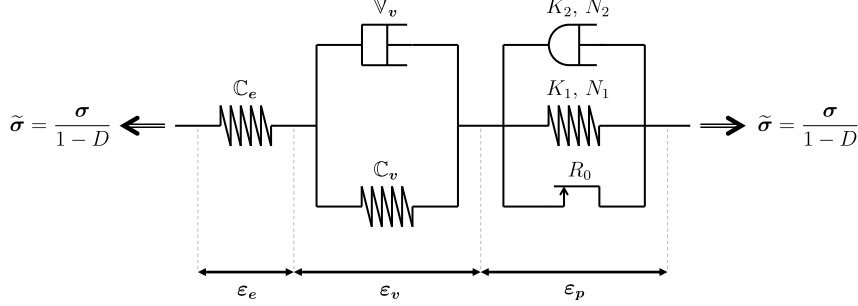

Figure 2: Rheological scheme of the PA66 matrix

thermodynamic potential given in (5), the stress is defined by derivation of this potential with respect to the total strain  $\boldsymbol{\varepsilon}$ :

$$\boldsymbol{\sigma} = \rho \frac{\partial \psi}{\partial \boldsymbol{\varepsilon}} = (1 - D)\mathbb{C}_e : \underbrace{(\boldsymbol{\varepsilon} - \boldsymbol{\varepsilon}_v - \boldsymbol{\varepsilon}_p)}_{\boldsymbol{\varepsilon}_e}. \quad (6)$$

In the same manner, the associative variables are obtained by derivation of the potential with respect to the internal state variables:

$$-\boldsymbol{\sigma}_v = \rho \frac{\partial \psi}{\partial \boldsymbol{\varepsilon}_v}, \quad -\boldsymbol{\sigma} = \rho \frac{\partial \psi}{\partial \boldsymbol{\varepsilon}_p}, \quad R(r) = \rho \frac{\partial \psi}{\partial r}, \quad -Y = \rho \frac{\partial \psi}{\partial D}, \quad (7)$$

where  $\boldsymbol{\sigma}_v$ ,  $R(r)$  and  $Y$  denote the viscous stress in the linear dash-pot (associated to the viscoelastic strain), the hardening function and the energy density release respectively. The evolution of the viscoelastic strain  $\boldsymbol{\varepsilon}_v$  is given by derivation of a pseudo-potential in which the expression of the viscous stress  $\boldsymbol{\sigma}_v$  is substituted. This finally gives a Kelvin-Voigt branch shown in Figure 2 which allows to express the stress as a function of the viscous strain  $\boldsymbol{\varepsilon}_v$  and its rate:

$$\frac{\boldsymbol{\sigma}}{1 - D} = \mathbb{C}_v : \boldsymbol{\varepsilon}_v + \mathbb{V}_v : \dot{\boldsymbol{\varepsilon}}_v. \quad (8)$$

In the above expression,  $\mathbb{V}_v$  is a fourth order viscosity tensor (classically defined for bulk isotropic media). The evolutions of the viscoplastic strain  $\boldsymbol{\varepsilon}_p$  and the damage variable  $D$  are both ruled by a dissipation surface [11] that once derived links both of them to the viscoplastic multiplier ( $\dot{\lambda} = \dot{r}$ ):

$$\dot{\boldsymbol{\varepsilon}}_p = \frac{3}{2} \frac{\mathbf{dev}(\boldsymbol{\sigma})}{eq(\boldsymbol{\sigma})} \frac{\dot{r}}{1 - D}, \quad \dot{D} = \left(\frac{Y}{S}\right)^\beta \frac{\dot{r}}{1 - D}, \quad (9)$$

where  $\mathbf{dev}(\boldsymbol{\sigma})$  and  $eq(\boldsymbol{\sigma})$  denote the deviatoric part of the stress tensor and the Von Mises equivalent stress respectively, while  $S$  and  $\beta$  are material parameters. The evolution of the multiplier  $\dot{r}$  is only activated ( $\dot{r} > 0$ ) when the criterion function  $f$  becomes positive. Then, its evolution can be written by expressing the equality between the positive part of  $f$  and the non-linear viscous stress (associated to the viscoplastic strain) given by the function  $Q(\dot{r})$ :

$$\left\langle \underbrace{\frac{eq(\boldsymbol{\sigma})}{1 - D} - R(r) - R_0}_f \right\rangle_+ = Q(\dot{r}). \quad (10)$$

In the proposed model, the hardening and viscous stress functions  $R(r)$  and  $Q(\dot{r})$  are both written under the form of power laws.

$$R(r) = K_1 r^{N_1}, \quad Q(\dot{r}) = K_2 \dot{r}^{N_2}. \quad (11)$$

This type of modelling presents the capability of capturing some well known phenomena occurring during cyclic loading such as the stiffness loss or the plastic strain accumulation [12].

## 4.2. Constitutive laws of the yarns

As previously mentioned, the yarns are composed of numerous fibres unidirectionally oriented along the first direction. Consequently they can be considered as an equivalent material that is supposed to be initially transversely isotropic. Since the intra-yarns volume fraction is quite high, the associated damage mechanisms are mainly due to debonding effects that gradually propagate to form transverse micro cracks. In order to capture the previously described mechanism, it is proposed to consider a hybrid micro-phenomenological approach [13] accounting for the anisotropic stiffness loss induced by oriented micro cracks. As for the matrix, the model of the yarns is written in the framework of thermodynamics, the state laws are then defined through the Helmholtz free energy written under the following form:

$$\rho\psi(\boldsymbol{\varepsilon}, \gamma_c) = \frac{1}{2} \boldsymbol{\varepsilon} : (\mathbb{C}_0 - \mathbb{D}(\gamma_c)) : \boldsymbol{\varepsilon}, \quad (12)$$

where  $\mathbb{C}_0$  is the initial fourth order stiffness tensors (classically defined for transversely isotropic medium) and  $\mathbb{D}(\gamma_c)$  another fourth order tensor that defines the anisotropic stiffness loss induced by the presence of micro cracks quantified by the internal variable  $\gamma_c$ . According to the thermodynamic potential given in (12), the stress and the energy density release are defined by derivation of this potential with respect to the total strain  $\boldsymbol{\varepsilon}$  and the variable  $\gamma_c$  respectively:

$$\boldsymbol{\sigma} = \rho \frac{\partial \psi}{\partial \boldsymbol{\varepsilon}} = (\mathbb{C}_0 - \mathbb{D}(\gamma_c)) : \boldsymbol{\varepsilon}, \quad -Y_c = \rho \frac{\partial \psi}{\partial \gamma_c} = -\frac{1}{2} \boldsymbol{\varepsilon} : \frac{\partial \mathbb{D}(\gamma_c)}{\partial \gamma_c} : \boldsymbol{\varepsilon}. \quad (13)$$

The constitutive law of the yarns then depends on the variable  $\gamma_c$  and consequently the expression of the stiffness loss tensor  $\mathbb{D}(\gamma_c)$ . Considering micro cracks as quasi flat ellipsoidal inclusions of void [5–7] (inclusions with zero stiffness) perpendicularly oriented to the second direction  $\vec{e}_2$  (see Figure 3), an explicit expression of the stiffness loss tensor can be obtained according to the volume fraction of created voids that are directly represented by the internal variable  $\gamma_c$  (micro crack density). The second local direction  $\vec{e}_2$  is parallel to the plane of the woven pattern (see Figure 1b). Using the micromechanical

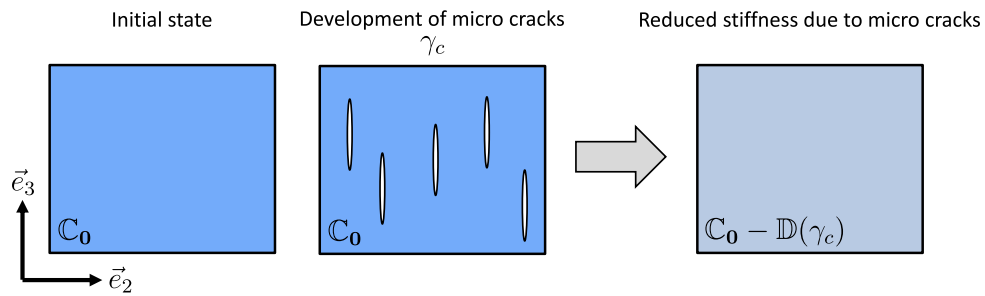

Figure 3: Assessment of the stiffness loss of the yarn using micromechanics

scheme of Mori-Tanaka [4] based on the Eshelby's solution [14], the expression of the stiffness loss tensor  $\mathbb{D}(\gamma_c)$  can be directly deduced:

$$\mathbb{D}(\gamma_c) = \gamma_c \mathbb{C}_0 : \mathbb{T}_c : \mathbb{A}_0(\gamma_c) \quad \text{with} \quad \mathbb{T}_c = (\mathbb{I} - \mathbb{S}_E)^{-1} \quad \text{and} \quad \mathbb{A}_0(\gamma_c) = (\mathbb{I} + \gamma_c(\mathbb{T}_c - \mathbb{I}))^{-1}, \quad (14)$$

where  $\mathbb{I}$  is the fourth order identity tensor,  $\mathbb{T}_c$  the strain interaction tensor of the void inclusion and  $\mathbb{A}_0(\gamma_c)$  the strain localisation tensor of the reference medium.  $\mathbb{S}_E$  denotes the Eshelby tensor that depends on the stiffness tensor of the reference medium  $\mathbb{C}_0$  and the aspect ratios of the void inclusion (quasi flat ellipsoid). In the present case, since the reference medium is not isotropic, the Eshelby tensor  $\mathbb{S}_E$  must be numerically evaluated using the integration scheme proposed by [15]. Next, a Weibull like evolution law is used to drive the growth of micro crack density:

$$\gamma_c = \gamma_c^s \left[ 1 - \exp \left( - \left[ \frac{\langle \text{sup}(Y_c) - Y_c^0 \rangle_+}{S} \right]^\beta \right) \right], \quad (15)$$

where  $S$  and  $\beta$  are material parameters,  $Y_c^0$  the damage threshold and  $\gamma_c^s$  the level of micro cracks saturation.

## 5. Virtual testing

In order to demonstrate the capabilities of the proposed approach, a series of virtual tests are performed using material parameters that provide realistic tendencies with respect to experimental observations. At first, off axis monotonic tensile tests have been computed for four different orientations ( $0^\circ$ ,  $15^\circ$ ,  $30^\circ$  and  $45^\circ$ ). The results presented in Figure 4 highlight well the anisotropy induced by the microstructure. Indeed, the composite tends to have a quasi linear elastic behaviour when loaded along the yarns. In this case, even if damage mechanisms occur in the matrix and in the transversal yarns (Figure 5), the longitudinal yarns can still carry much of the load. Consequently, the induced stiffness loss remains very small at the macroscopic scale. When not loaded in the yarns direction ( $45^\circ$ ), the behaviour of the composite becomes strongly non linear, mainly due to the appearance of shear that quickly degrades the stiffness properties of yarns. At high stress levels, the load is almost exclusively carried by the matrix.

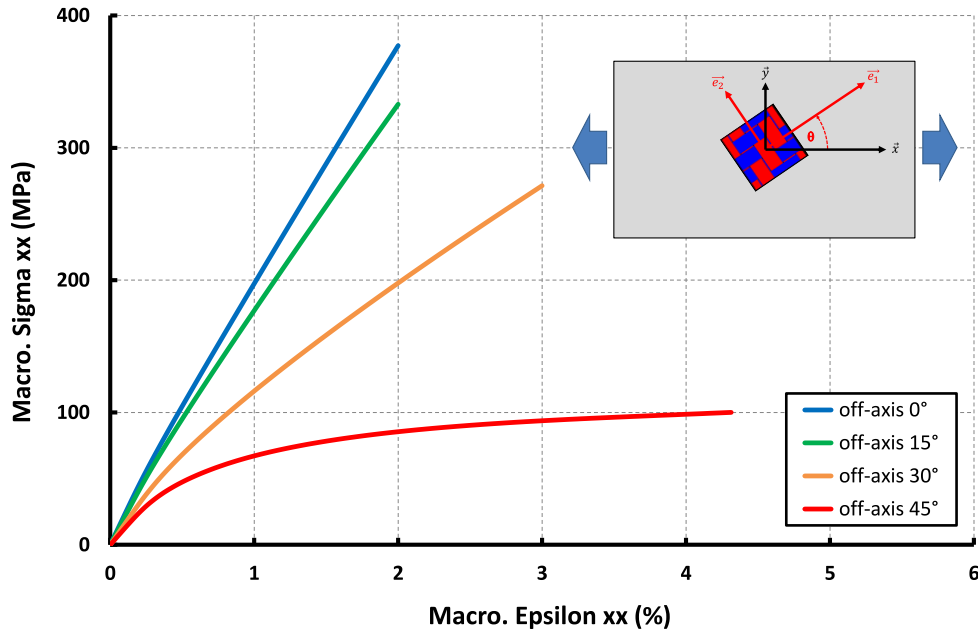

Figure 4: Simulated off-axis tensile tests

In the next example, a cyclic in-plane shear test has been simulated. The results presented in Figure 6 show a strongly non-linear behaviour similar to the one that has been previously observed for the  $45^\circ$  tensile test. Nevertheless, it can be seen through cyclic loading that the peak stress decreases because

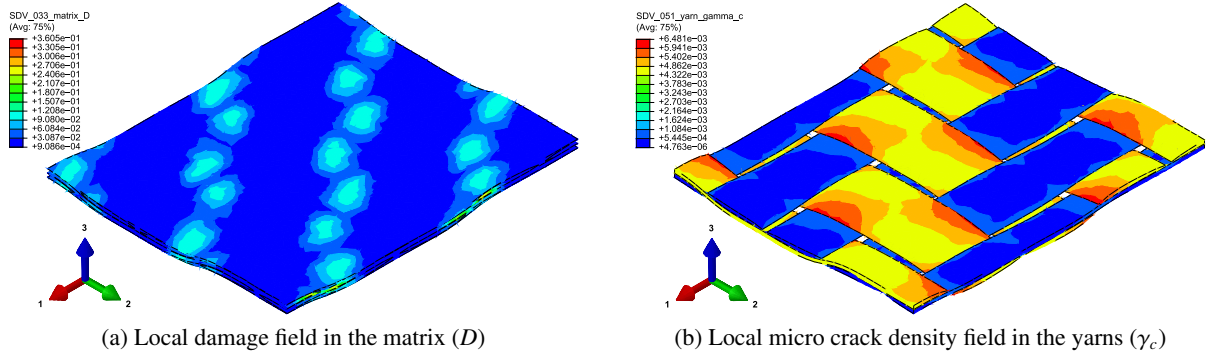

Figure 5: Local fields inside the unit cell for the  $0^\circ$  tensile test (at the end of the simulation)

of the cyclic dependent viscoplastic strain and damage accumulation of the matrix. Moreover, a micro crack accumulation also appears inside the yarns. Since the yarns in principle have a rate independent response, the cyclic effect is due to the microstructural coupling between the matrix and the yarns. This behaviour tends to stabilize after a certain number of cycles.

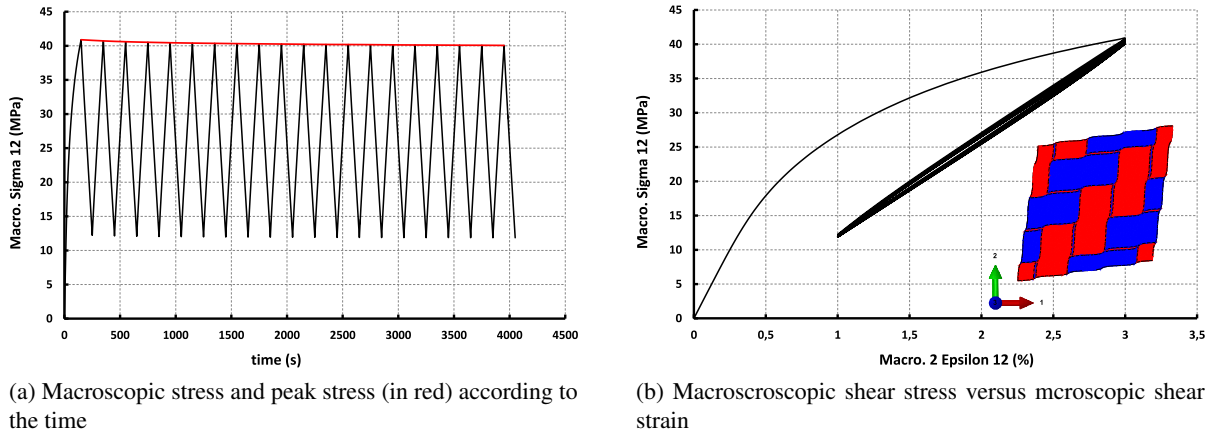

Figure 6: Simulated cyclic shear test

## 6. Conclusion

Through this document, a global framework using the concept of periodic homogenization has been introduced and applied to build a meta-model for woven composites. The presented approach shows very good capabilities in simulating the non linear behaviour of periodic media, exhibiting the effects of both microstructure and local behaviour. The chosen local constitutive laws allows to account for certain couplings between the damage mechanisms and the viscous aspect of the matrix. The capabilities of the established meta-model have been shown through virtual testing, including off axis monotonic and cyclic loading. The obtained results reproduce some known tendencies for thermoplastic woven composites.

## Acknowledgments

This paper is part of the COPERSIM project managed by IRT Jules Verne (French Institute in Research and Technology in Advanced Manufacturing Technologies for Composite, Metallic and Hybrid Structures). The authors wish to associate the industrial and academic partners of this project; respectively Arts et Metiers ParisTech, Solvay, Plastic Omnium, PSA and Renault.

## References

- [1] J.-C. Michel, H. Moulinec, and P. Suquet. Effective properties of composite materials with periodic microstructure: a computational approach. *Computer methods in applied mechanics and engineering*, 172:109–143, 1999.
- [2] G. Chatzigeorgiou, Y. Chemisky, and F. Meraghni. Computational micro to macro transitions for shape memory alloy composites using periodic homogenization. *Smart Materials and Structures*, 24, 2015.
- [3] S. Li and A. Wongsto. Unit cells for micromechanical analyses of particle-reinforced composites. *Mechanics of Materials*, 36:543–572, 2004.
- [4] T. Mori and K. Tanaka. Average stress in matrix and average elastic energy of materials with misfitting inclusions. *Acta Metallurgica*, 21:571–574, 1973.
- [5] F. Meraghni and M.-L. Benzeggagh. Micromechanical modelling of matrix degradation in randomly oriented discontinuous-fibre composites. *Composites science and technology*, 55:171–186, 1995.
- [6] F. Meraghni, C.-J. Blakeman, and M.-L. Benzeggagh. Effect of interfacial decohesion on stiffness reduction in a random discontinuous-fibre composite containing matrix microcracks. *Composites science and technology*, 56:541–555, 1996.
- [7] F. Meraghni, F. Desrumaux, and M.-L. Benzeggagh. Implementation of a constitutive micromechanical model for damage analysis in glass mat reinforced composite structures. *Composites science and technology*, 62:2087–2097, 2002.
- [8] M. Sherburn. *Geometric and mechanical modelling of textiles*. PhD thesis, University of Nottingham, 2007.
- [9] J. Lemaitre and J.-L. Chaboche. *Mécanique des matériaux Solides*. Dunod, 1985.
- [10] J. Lemaitre and R. Desmorat. *Engineering damage mechanics : ductile, creep, fatigue and brittle failure*. Springer, 2005.
- [11] J. Lemaitre. Coupled elasto-plasticity and damage constitutive equations. *Computer methods in applied mechanics and engineering*, 51:31–49, 1985.
- [12] A. Krairi and I. Doghri. A thermodynamically-based constitutive model, for thermoplastic polymers coupling viscoelasticity viscoplasticity and ductile damage. *International Journal of Plasticity*, 60:163–181, 2014.
- [13] G. Couégnat. *Approche multiéchelle du comportement du comportement mécanique de matériaux composites à renfort tissé*. PhD thesis, Université Bordeaux I, 2008.
- [14] J.-D. Eshelby. The Determination of the Elastic Field of an Ellipsoidal Inclusion, and Related Problems. *Proceedings of the Royal Society of London*, A(241):376–396, 1957.
- [15] A.-C. Gavazzi and D.-C. Lagoudas. On the numerical evaluation of Eshelby’s tensor and its application to elastoplastic fibrous composites. *computational Mechanics*, 7:13–19, 1990.