



Science Arts & Métiers (SAM)

is an open access repository that collects the work of Arts et Métiers Institute of Technology researchers and makes it freely available over the web where possible.

This is an author-deposited version published in: <https://sam.ensam.eu>
Handle ID: [.http://hdl.handle.net/10985/14956](http://hdl.handle.net/10985/14956)

To cite this version :

Wenyu CHENG, Jose Carlos MARTINS DO OUTEIRO, Jean-Philippe COSTES, Rachid M'SAOUBI, Habib KARAOUNI, Lamice DENGUIR, Viktor ASTAKHOV, François AUZENAT - Constitutive model incorporating the strain-rate and state of stress effects for machining simulation of titanium alloy Ti6Al4V - In: 8th CIRP Conference on High Performance Cutting (HPC 2018), Hongrie, 2018-06-25 - Procedia CIRP - 2018

Any correspondence concerning this service should be sent to the repository

Administrator : scienceouverte@ensam.eu



8th CIRP Conference on High Performance Cutting

Constitutive model incorporating the strain-rate and state of stress effects for machining simulation of titanium alloy Ti6Al4V

Wenyu Cheng^{a,*}, Jose Outeiro^a, Jean-Philippe Costes^a, Rachid M'Saoubi^b, Habib Karaouni^c, Lamice Denguir^a, Viktor Astakhov^d, François Auzenat^e

^aArts et Metiers ParisTech, LaBoMaP, Rue Porte de Paris, 71250 Cluny, France

^bR&D Material and Technology Development Seco Tools AB, SE-73782 Fagersta, Sweden

^cSafran Tech, Research and Technology Center, 78772 Magny-Les-Hameaux, France

^dProduction Service Management Inc. (PSMI), Saline, MI, USA

^eR and D milling and process, 22 avenue de la prospective 18020 bourges cedex

* Corresponding author. E-mail address: wenyu.cheng@ensam.eu

Abstract

Ti6Al4V titanium alloy is widely used in aero-engines due to its superior performance. However, as a difficult-to-cut alloy, it induces short cutting tool life and poor surface integrity. To improve these process outcomes, numerical simulations are of importance. The predictive ability of such simulation depends on the accuracy of the constitutive model which describes the work material behavior under loading conditions specific to metal cutting. Therefore, the focus of this paper is the formulation of a constitutive model to be used in the orthogonal cutting simulation of Ti6Al4V. The distinguished feature of this model is its simplicity, accounting for the strain-rate and state of stress effects in the work material deformation and fracture. The model coefficients were identified using mechanical tests and numerical simulations with specially-designed test specimens to cover a wide range of strain-rates and state of stress. Orthogonal cutting simulations were performed and the obtained results were compared with those measured.

© 2018 The Authors. Published by Elsevier Ltd. This is an open access article under the CC BY-NC-ND license (<http://creativecommons.org/licenses/by-nc-nd/3.0/>)

Peer-review under responsibility of the International Scientific Committee of the 8th CIRP Conference on High Performance Cutting (HPC 2018).

Keywords: Constitutive model, Metal cutting simulation, State of stress

1. Introduction

Titanium alloy Ti6Al4V is widely used in the aerospace industry due to its superior performances, including excellent specific strength, acceptable mechanical behavior at elevated temperature, and high corrosion and creep resistances. However, it is a difficult-to-cut alloy, machining of which requires higher cutting energy compared with other low-weight aerospace alloys. Great efforts have been made to improve efficiency of its machining without compromising its service properties. Modelling is a powerful approach to analyze and thus potentially optimize the metal cutting

process. The quality of the predictions highly depends on adequacy of the work material behavior (constitutive) and friction models to describe the mechanical and tribological behaviors of the work material in metal cutting [1]. Therefore, a key point in metal cutting modelling is to use an accurate constitutive model of the work material, able to describe the work material behavior under the loading conditions specific to this process.

Traditionally, constitutive models for metal cutting simulation include the effects of strain hardening, strain-rate (viscosity), thermal softening and microstructure (such as grain size) [1]. However, most of the constitutive models do

not account for the influence of the state of stress on the work material behavior.

The state of stress is characterized by two parameters: the stress triaxiality and the Lode angle [2]. Several research works have demonstrated the significant effect of the state of stress not only in damage characterisation but also on flow stress [2]. A broad range of stress state distributes in the deformation zone takes place in the cutting process depending upon various cutting parameters. Abushawashi et al. [3] showed that the state of stress could control the strength of the produced chip.

This is of particular importance because metal cutting is the physical separation of the layer being removed (in the form of chips) from the rest of the workpiece. The process of physical separation of a solid body into two or more parts is known as fracture, and thus machining must be treated as the purposeful fracture of the layer being removed [4]. Therefore, the proper modeling of the work material in metal cutting should take into account the determination of the evolution of the material flow stress under similar conditions as those observed in metal cutting, as well as determination of conditions of fracture occurrence. Fig. 1 shows a graphical representation of the material's constitutive model with fracture. The solid line is the real curve. The dashed line is a hypothetical undamaged stress–strain curve commonly used to represent the work material behavior in metal cutting modeling. As shown, at point B, the experimental yield surface starts to depart from the virtual undamaged yield surface. Point B marks the damage initiation. From this point on, both the elastic modulus and the plastic flow resistance degrade with increasing strain. The macroscopic measured response from point B to point E corresponds to microscopic damage evolution till final fracture. The difference between solid line representing experimental data and dashed line representing hypothetic undamaged curve is evaluated by damage parameter D . When D equals 1, the complete fracture occurs at point E corresponding to fracture strain $\bar{\epsilon}_f^p$.

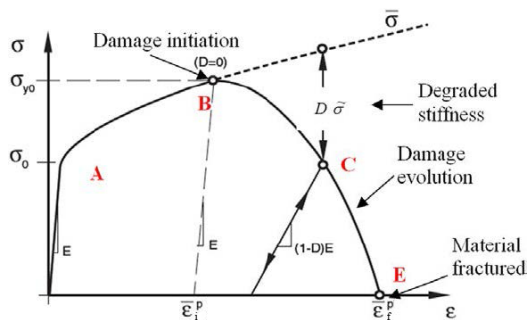

Fig. 1. Stress–strain curve with progressive damage degradation [5].

According to ductile failure phenomenon, two steps are included in the chip formation: first step is damage initiation, the other is damage evolution. Several damage initiation models can be used such the Johnson-Cook (JC) [6] and the Bai-Wierzbicki (B-W) [2] damage models.

In the current work, a constitutive model, including flow stress and damage models, is proposed for the orthogonal cutting simulation of Ti6Al4V. This model includes the effect of the state of stress of both flow stress and damage of the work material. The identification of the model coefficients is

carried out using the result of mechanical tests with different test specimen designs, to cover the range of strain-rates and states of stress particular to metal cutting.

2. Proposed constitutive model formulation

The proposed constitutive model is a composition of the flow stress and damage models. The flow stress model includes the most significant factors which influence mechanical behavior of the work material in the primary deformation zone (PDZ) in orthogonal metal cutting, i.e., strain hardening [6], the strain-rate [7], and the state of stress effect [2]. It is represented by Eq. 1.

$$\bar{\sigma} = [A + m\epsilon_p^n] [B + C \ln (E + \frac{\dot{\epsilon}}{\dot{\epsilon}_0})] [1 - c_\eta(\eta - \eta_0)] \quad (1)$$

where: i) A , m , and n are material coefficients for strain hardening effect; ii) B , C , E are the material coefficients for strain-rate effect; iii) c_η is a material coefficient for stress triaxiality effect; and iv) η_0 and $\dot{\epsilon}_0$ are the reference values of stress triaxiality and strain-rate. Particularly, stress triaxiality is the ratio between mean stress σ_m (average of principal stress) and equivalent von-Mises stress $\bar{\sigma}$, that is $\eta = \frac{\sigma_m}{\bar{\sigma}}$. A thermal softening term is not included in the model for two reasons. First, mechanical tests at high strain rates already include the temperature effect due to conversion of plastic deformation into heat. Second, temperature of the workpiece in the first deformation zone hardly exceeds 200°C due to mass transportation (i.e. heat advection) by the moving chip [8].

As the damage model is concerned, it includes the damage initiation and damage evolution. JC damage initiation model without thermal effects is used (Eq. 2), while damage evolution is given by Eq. 3 and 4.

$$\bar{\epsilon}_i^p = (D_1 + D_2 e^{D_3 \eta}) [1 + D_4 \ln (\frac{\dot{\epsilon}}{\dot{\epsilon}_0})] \quad (2)$$

$$\bar{\sigma} = (1 - D) \bar{\sigma} \quad (3)$$

$$D = \frac{\int_{\bar{\epsilon}_i^p}^{\bar{\epsilon}_f^p} \bar{\sigma} d\bar{\epsilon}^p}{G_f}, G_f = \int_{\bar{\epsilon}_i^p}^{\bar{\epsilon}_f^p} \bar{\sigma} d\bar{\epsilon}^p \quad (4)$$

where: i) D_1 - D_4 are the coefficients of the damage initiation model and G_f is the fracture energy; ii) $\bar{\epsilon}_i^p$ is the plastic strain at damage initiation; and iii) $\bar{\epsilon}_f^p$ is the plastic strain at the point where material has lost all its stiffness and dissipates all the fracture energy.

The Lode angle parameter is not considered in both flow stress and damage models because the value of Lode angle parameter remains zero for plane strain condition as in orthogonal metal cutting.

3. Experimental mechanical tests and constitutive model coefficients identification

3.1 Test specimen configurations

The coefficients identification procedure requires three kinds of specimens' geometry: cylindrical, smooth round bar and double notched specimen (see Fig. 2). These specimens' geometries were chosen in order to obtain different stress

triaxiality values. These values for the cylinder in compression and the smooth round bar in tension are well known and equal to -0.33 and 0.33, respectively [2]. For the double notched specimen, the stress triaxiality value depends on the pressure angle defined as the angle between the hole centers as shown in the Fig.2 (c). Altering this angle, one can achieve different stress triaxialities states.

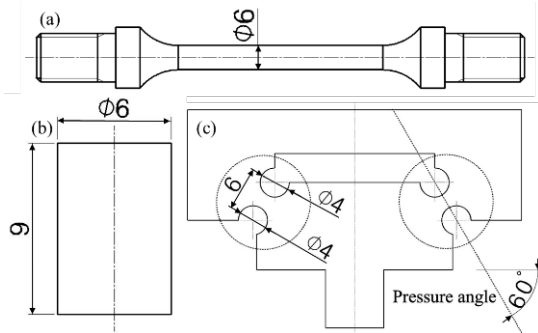

Fig. 2. Specimens' geometries: (a) smooth round bar (b) cylindrical and (c) double notched.

Simulation of quasi-static compression test of double notched specimen with a pressure angle of 90° was performed. Fig 3a shows the distribution of equivalent plastic strain before fracture initiation, inside the circle represented in Fig. 2c. Then, stress triaxiality is plotted along the path connecting the two points of maximum plastic strain (Fig. 3b). The fracture initiates (fracture locus) where stress triaxiality along this path is less negative/more positive. In this case the stress triaxiality at fracture initiation is equal to 0.02.

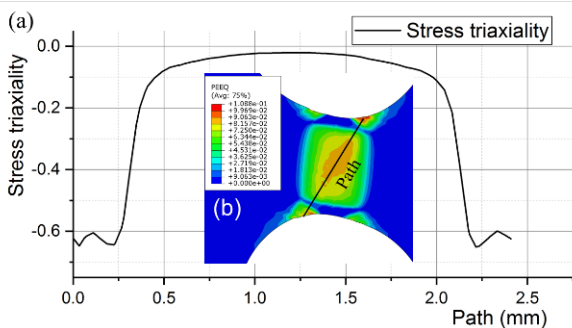

Fig.3. Simulated results (pressure angle of 90°): (a) Stress triaxiality along the selected path in damage initiation and; (b) Plastic strain distribution

3.2 Identifications of the flow stress model coefficients

A quasi-static compression test of a cylinder at room temperature is used as the reference tests, so that $\eta_0 = -1/3$ and $\dot{\epsilon}_0 = 1 \text{ s}^{-1}$. Therefore, Eq.1 is reduced to the first two terms, i.e. the strain hardening and strain-rate effects. A, m, n, B, C, and E coefficients are identified based on the stress-strain curves obtained in the quasi-static compression test, using a servohydraulic testing machine, and dynamic tests at several strain rates, using a Split Hopkinson Pressure Bar (SHPB) apparatus, of the cylindrical specimens. A direct method [1] based on tridimensional surface fitting to the experimental data is used to identify the above-mentioned

coefficients. Figure 4, shows the experimental data (red dots) and the corresponding fitted surface (in cyan) representing the first two terms of equation 1, whose coefficients values are given in Table 1.

In order to identify value of c_η coefficient value, quasi-static compression tests were carried out using the double notched specimen on a servohydraulic testing machine. The value of c_η was modified iteratively in order to the simulated force-displacement curve fits the experimental one. Table 1 shows all the flow stress model coefficients.

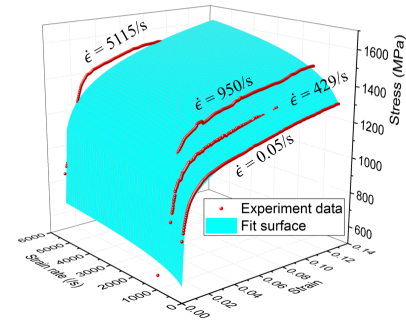

Fig. 4. Fit surface of experimental stress-strain curve.

Table 1. Coefficients of the flow stress model.

Coef.	A	m	n	B	C	E	c_η
Value	232.1	439.6	0.199	1.193	0.227	367.9	0.05

3.3 Identifications of the damage model coefficients

Fracture locus at different strain-rates were obtained from the compression tests using the cylindrical specimens, which permitted to determine the coefficient D_4 of the damage initiation model. The other coefficients of this model were obtained using the three specimens' geometries shown in Fig. 2, each one corresponding to a given stress triaxiality value, presented in the previous section. Figure 5 shows three experimental points representing these stress triaxiality values and the corresponding fracture locus. The red line is the fitting curve, given by the first term of Eq. 2. The coefficients of the damage initiation model are shown in Table 2.

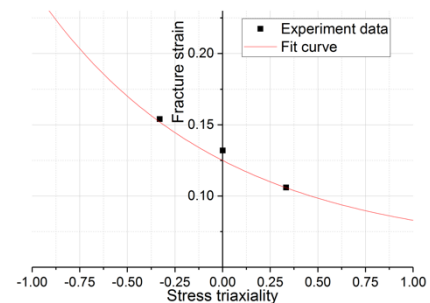

Fig. 5. Stress triaxiality vs. fracture strain.

As far as the damage evolution is concerned, a fracture energy density G_f value of 50 MJ/m³ was calculated based on numerical integration of the area below the stress-strain curve and beyond damage initiation point B as shown in the Fig. 1.

Table 2. Coefficients of the damage initiation model.

Coef.	D ₁	D ₂	D ₃	D ₄
Value	0.061	0.064	-1.065	0.027

4. Metal cutting simulation

4.1 Orthogonal cutting model

2D orthogonal cutting model of Ti6Al4V was developed and simulated using the Finite Element Method (FEM). A coupled temperature-displacement analysis was performed using ABAQUS/Explicit FEA software. The contact conditions over the tool-chip and the tool-workpiece, interfaces were modelled using the Zorev's model [9] with friction coefficient equaling to 0.2 [10]. During cutting simulations, the workpiece is fixed while the tool advances at a constant cutting speed. The intermediate layer is used to simulate the physical separation of the layer being removed (in the form of chips) from the rest of the workpiece. The proposed constitutive model was implemented in ABAQUS through a VUMAT subroutine. Thermal and elastic properties of Ti6Al4V were provided by the TIMET company, while information of the tool material was taken from Outeiro et al. [11]. The tool has a rake angle (γ) of 6°, a flank angle (α) of 7°, and a cutting edge radius (r_n) of 30 μm . The cutting speed (v_c) was 55 m/min, the uncut chip thickness (h) 0.15 mm and the width of cut (b) 4 mm.

4.2 Simulation results

Figure 6 presents both experimental [11] and simulated results concerning to the chip geometry, chip compression ratio (CCR) and cutting force. It can be seen the chip shape and cutting force is well predicted by this model. However, there is a noticeable difference between the calculated and experimentally-obtained values of CCR.

	Experiment	Simulation
Peak (μm)	226.7 \pm 12.1	139.5
Valley (μm)	116.6 \pm 13.1	81.9
Pitch (μm)	161.3 \pm 24.3	100.5
CCR	1.51 \pm 0.08	0.93

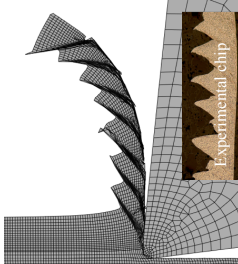

Fig. 6. Comparison between experimental [11] and simulated results.

There are two main reasons for this difference. One is the effect of stress triaxiality identified in damage model, which decides the material strain limit, and then influences shear bands creation. The distribution of stress triaxiality in the workpiece in cutting is almost entirely negative whereas the only signal negative value is obtained in the test with the cylindrical specimen. The specimens design which can produce various negative values should be developed. The other is accounting for the contact conditions over the tribological interfaces that is carried out through the assigning a constant value of the friction coefficient. To improve the

modeling of the contact stress distributions, a better model should be developed accounting for the result of tribological experiments.

5. Conclusion

A constitutive model of Ti6Al4V for orthogonal cutting simulation is proposed. This model considers the effects of strain hardening, strain-rate and state of stress. The flow stress model was validated by the quasi-static compression tests of cylinders. The chip geometry and cutting force are well predicted with proposed constitutive model, while the simulated CCR has a noticeable difference with experimental data due to the identified effects of stress triaxiality distribution and the contact model. Further mechanical and tribological tests will be performed to improve the model predictability.

Acknowledgements

The authors would like to express their gratitude for the financial support provided by Seco tools and Safran companies. The financial support from the China Scholarships Council program (No. 201606320213) is also appreciated. They would like also to thank to Prof. Pedro Rosa from TU Lisbon, Dr. Bertrand Marcon from Arts et Metiers Cluny and Prof. Xinran Xiao from Michigan State University for their expertise that assisted this research work.

Reference

- [1] S.N. Melkote, W. Grzesik, J.C. Outeiro, J. Rech, V. Schulze, H. Attia, P. Arrazola, R. M'Saoubi, C. Saldana, "Advances in material and friction data for modelling of metal machining", CIRP Annals - Manufacturing Technology, 2015, 66/2: 731-754.
- [2] Bai Y, Wierzbicki T. A new model of metal plasticity and fracture with pressure and Lode dependence, International Journal of Plasticity, 2008, 24:1071-1096.
- [3] Abushawashi Y M. Modeling of metal cutting as purposeful fracture of work materials[M]. Michigan State University, 2013..
- [4] Astakhov V P, et al. The bending moment as the cause for chip formation, Manufacturing Science and Engineering. 1997, 6:53-60.
- [5] ABAQUS/Explicit Analysis User Manual, Version 6.11.
- [6] Johnson G R, Cook W H. Fracture characteristics of three metals subjected to various strains, strain rates, temperatures and pressures. Engineering fracture mechanics, 1985, 21(1): 31-48.
- [7] Silva CMA, Rosa PAR, Martins PAF. Electromagnetic cam driven compression testing equipment. Exp Mech, 2012, 52(8):1211–22.
- [8] Bushawashi Y, Xiao X, Astakhov V P. Heat conduction vs. heat advection in metal cutting[J]. Int. J. Advances in Machining and Forming Operations, 2012, 4(2): 133.
- [9] N.N. Zorev Metal Cutting Mechanics Pergamon Press, Oxford (1966).
- [10] Courbon C, Pusavec F, Dumont F, et al. Influence of cryogenic lubrication on the tribological properties of Ti6Al4V and Inconel 718 alloys under extreme contact conditions. Lubrication Science, 2014, 26(5): 315-326.
- [11] Outeiro JC, Umbrello D, M'Saoubi R, Jawahir IS. Evaluation of present numerical models for predicting metal cutting performance and residual stresses. Machining Science and Technology, 2015, 19(2):183–216.