



Science Arts & Métiers (SAM)

is an open access repository that collects the work of Arts et Métiers Institute of Technology researchers and makes it freely available over the web where possible.

This is an author-deposited version published in: <https://sam.ensam.eu>
Handle ID: <http://hdl.handle.net/10985/19376>

To cite this version :

Viet-Duc LE, Etienne PESSARD, Franck MOREL, Serge PRIGENT - Fatigue behaviour of additively manufactured Ti-6Al-4V alloy: The role of defects on scatter and statistical size effect - International Journal of Fatigue - Vol. 140, p.105811 - 2020

Any correspondence concerning this service should be sent to the repository

Administrator : scienceouverte@ensam.eu



Fatigue behaviour of Additively Manufactured Ti-6Al-4V alloy : the role of defects on scatter and statistical size effect

Viet-Duc LE^{a,*}, Etienne PESSARD^a, Franck MOREL^a, Serge PRIGENT^b

^aArts et Metiers Institute of Technology, LAMPA, HESAM Université, Address :F-49035 Angers, FRANCE

^bIRT Jules Verne, 44340-Bouguenais, FRANCE

Abstract

This work is focused on the influence of defects on scatter and statistical size effect of Ti-6Al-4V alloy fabricated by the SLM process. A vast fatigue test campaign has been undertaken, for two surface conditions (as-built and machined surfaces) and two specimen geometries with different highly loaded volume sizes. It was shown, for machined specimens, that a large variety of crack initiation mechanisms is the principal origin of the fatigue scatter. Regarding the size effect, the change of the mechanism is the first order factor that governs the size effect. For as-built specimens, these effects are much less pronounced.

Keywords: Fatigue behaviour; Additive manufacturing; Ti-6Al-4V; porosity; size effect

1. Introduction

For most metallic materials, the microstructure, microstructural defects and surface roughness are the fingerprints for the prediction of their macroscopic mechanical behaviour. For the case of Selective Laser Melting (SLM) of metal Additive Manufacturing (AM), the precise control of the microstructure, porosity (i.e. gas and Lack-of-Fusion (LoF) pores) and surface roughness is not easily achievable. This has proven to be very challenging for getting high-performance Ti-6Al-4V alloy, most commonly used in the aeronautical and bio-mechanical industries.

The principal objective of this paper is to contribute to the comprehension of the effect of the two main defect types found in SLM additively manufactured Ti-6Al-4V alloys, porosity and

*Corresponding author: Viet-Duc LE

Email address: viet-duc.le@ensam.eu (Viet-Duc LE)

10 surface roughness, on the fatigue behaviour in the high cycle fatigue regime. In the scientific
11 literature, the effect of these factors on the fatigue strength has been investigated in numerous
12 studies. Concerning the effect of the porosity, several studies have highlighted the effect of pore
13 size on the fatigue behaviour of AM Ti-6Al-4V alloys [1–4]. In the work of Günther et al. [2], the
14 authors showed the presence of different defect types from which the fatigue crack initiates such as
15 LoF pores and gas pores or α -phase. The same observations were made in the work of Chastand et
16 al. [3] in which the authors observed several defect types such as surface defects, un-melted zones
17 and small defects. In order to model the effect of these defects on the fatigue strength, linear elastic
18 fracture mechanics based approaches have been widely used [5–7] and show globally satisfactory
19 predictions. However, very little work clearly characterises the fatigue behaviour related to each
20 defect type at the origin of the crack initiation sites.

21 Regarding the effect of the as built surface on the fatigue behaviour, numerous studies [8–12]
22 have shown that the as built surface is detrimental to the fatigue strength. Several approaches have
23 been developed in the literature to model the effect of surface roughness defects. Vayssette et
24 al. [8] tried to estimate the fatigue strength via numerical simulations by using the finite element
25 method and achieved satisfactory predictions. In the work of Nakatani et al. [11], the classical
26 Murakami approach is used in which the surface roughness defect size is measured by using the
27 \sqrt{area} parameter. However, it seems that this parameter alone is not adequate to achieve good
28 results. In the work of Nasab et al. [10], the authors tried to describe the competition between
29 crack initiation from surface pores and crack initiation from the surface roughness using a proba-
30 bilistic approach. However, none of these studies investigated the difference in the fatigue strength
31 between the as-built surface and a machined surface for the same crack initiation mechanism, in
32 particular when initiation from surface pores is dominant.

33 Concerning the scale/size effect, it was shown in the studies of Pegue et al. [13] and Fatemi et
34 al. [14] that the size effect on the fatigue behaviour for as-built surface specimens is not significant.
35 The authors showed that the fatigue strength of as-built specimens does not change significantly
36 when changing the gauge length and gauge diameter. For machined specimens, Fatemi et al. [14]
37 showed that the size effect is more pronounced. However, few analyses of the critical defects were
38 shown in these works to better understand the origin of the size effect.

39 The objective of the present work is to characterise the fatigue behaviour, in particular the
40 fatigue scatter and the size effect, of the Ti-6Al-4V alloy obtained by the SLM process. In order
41 to achieve this aim, 4 specimen configurations were fabricated and investigated, corresponding to
42 two surface conditions (as-built and machined surfaces) and to two specimen sizes (standard size
43 and small size).

44 In the first part of this paper, the material properties including the microstructures, the surface
45 roughness and the tensile properties are briefly presented, followed by the characterisation of the
46 fatigue behaviour and associated damage mechanisms. It will be shown that numerous different
47 fatigue crack initiation mechanisms are active. The critical defect size at the crack initiation sites
48 are also characterised.

49 In the second part of the paper, the link between the fatigue behaviour and the crack initiation
50 mechanisms is highlighted. The S-N curves are analysed separately for each damage mechanism.
51 In order to take into account the pore size, a "corrected stress", introduced in one of the present
52 authors previous publication [15], is used. A Kitagawa-Takahashi approach is also used to analyse
53 the effect of pore size on the fatigue strength. A comparison of the fatigue behaviour between
54 the machined and as-built surface, for the same fatigue damage mechanism, shows a pronounced
55 effect of the as-built surface.

56 In the final part, the statistical size effect on the fatigue strength will be discussed by comparing
57 the fatigue behaviour between the standard size and small size specimens. Finally, a probabilistic
58 approach is proposed to describe the statistical size effect. The model predicts the probability of
59 occurrence of the LoF pores, the most detrimental defect type, in a given volume.

60 1.1. Specimen fabrication

61 The titanium alloy used in this work is grade 23, Ti-6Al-4V ELI. The chemical composition is
62 shown in Table 1.

Al	V	C	Fe	H	N	O
6.0	4.0	≤ 0.08	≤ 0.25	≤ 0.012	≤ 0.05	≤ 0.13

Table 1: Standardized chemical composition (in weight percentage) of the Ti-6Al-4V alloy[16]

63 The powder was supplied by AP&C with a particle size range of 20 μm -63 μm with a median
 64 size of 43 μm . The specimens were manufactured by the Jules Verne Research and Technology
 65 Institute in France (IRT Jules Verne), using a SLM 280HL machine. The standard parameters
 66 recommended by the machine maker were used for the fabrication. In total, 68 fatigue specimens
 67 were fabricated, randomly mixed on 4 batches (two of them are shown in Figure 2).

68 In the previous work [15], several building directions (0° , 45° , 90°) were used in order to
 69 investigate the effect of this factor on the fatigue behaviour. In the present work, all of the spec-
 70 imens were fabricated vertically (i.e. the most critical building direction in relation to the fatigue
 71 strength) with two specimen geometries as shown in Figure 1. The standard size geometry is pro-
 72 posed in the standard ISO - NF EN 6072 - June 2012 while the small size geometry was chosen
 73 so that the loaded volume is much smaller than the standard size geometry without introducing a
 74 strong stress concentration. For information, the $V_{80\%}$ (highly loaded volume in which the lowest
 75 stress is equal to the 80% of the highest stress in the whole specimen) under uniaxial tensile loads
 76 corresponding to these two geometries are respectively 2044 mm^3 and 206 mm^3 .

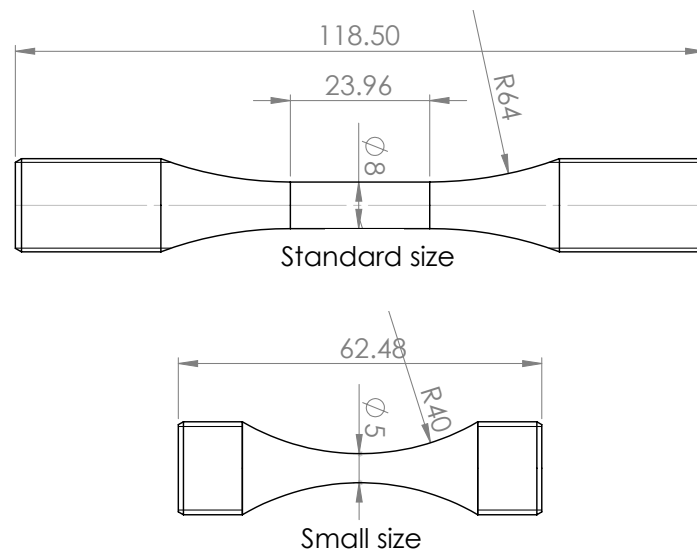

Figure 1: Two fatigue specimen geometries

77 All of the as-fabricated specimens were post-heat treated by the following heat treatment (an-
 78 nealing at 850 $^\circ\text{C}$ for 2 hours followed by slow cooling within the furnace) to relax the residual
 79 stresses due to fabrication.



Figure 2: Two (in a total of four) fabricated batches of specimens

80 The machining was realised after the post-heat treatment. For the as-built surface specimens,
 81 only the threaded heads were machined while the calibrated zone was left as-fabricated with the
 82 diameters as indicated in Figure 1, i.e. $\Phi 8$ mm for the standard size and $\Phi 5$ mm for the small
 83 size. For the machined surface configurations, the as-fabricated gauge diameters were $\Phi 10$ mm
 84 for standard size and $\Phi 7$ mm for small size. After removing 1 mm from the radius by machining,
 85 the gauge diameters of the machined specimens are the same as the as-built specimens. Four
 86 specimen configurations and the associated number of specimen are given in Table 2.

Configuration	Number of specimens
Standard size - Machined	20
Small size - Machined	19
Standard size - As-built	14
Small size - As-built	15

Table 2: Four specimen configurations and associated number of specimens

87 *1.2. Microstructure, surface roughness and tensile properties*

88 The microstructure was characterised by using an optical microscope to observe polished and
89 chemically etched samples. A columnar microstructure with the grains orientation parallel to the
90 building direction was observed as shown in Figure 3a and Figure 3b. This observation is in a
91 good agreement with works from the literature [15, 17].

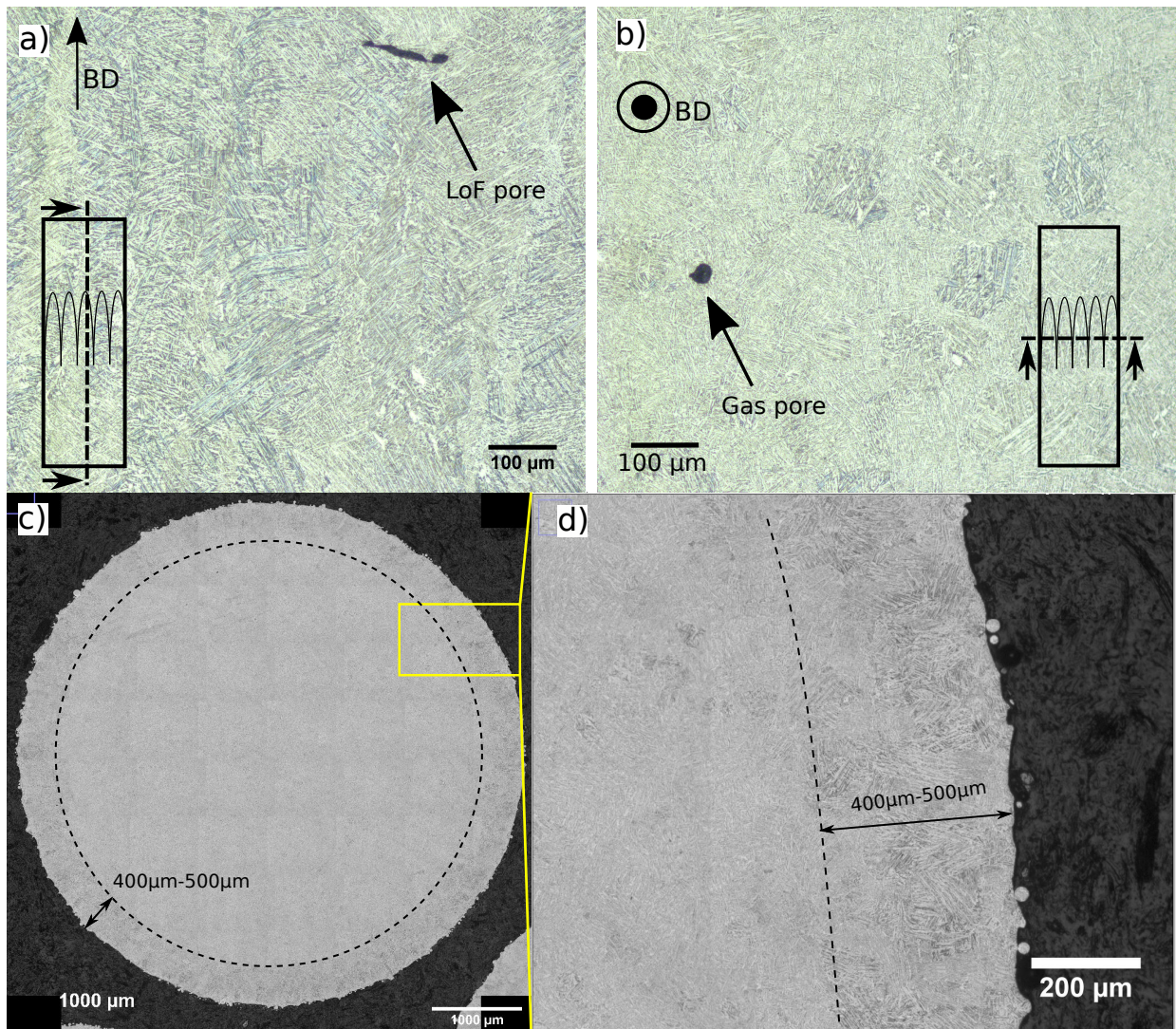

Figure 3: Microstructure of machined specimens (a) in a plane parallel to the build direction and (b) in a plane perpendicular to the building direction; (c) and (d): the microstructure close to the surface of as-built specimens in a perpendicular plane

92 For the as-built specimens (Figure 3c and Figure 3d), a sub-surface ring of 400 to 500 μm in

93 thickness can be seen in which the microstructure is coarser than the microstructure in the bulk.
94 Micro-hardness measurements using a HV0.2kg indenter showed that the average micro-hardness
95 in sub-surface zone is higher than that measured in the bulk (440 HV0.2 versus 370 HV0.2). The
96 higher hardness in the sub-surface layer may be linked to the formation of alpha case phase (i.e.
97 oxygen-enriched surface phase) that occurs when the alloy is exposed to heated air or oxygen.
98 This phase transformation can occur during either the fabrication or the heat treatments. For
99 the machined specimens, the micro-hardness is homogeneous and similar to the micro-hardness
100 measured in the bulk of the as-built specimens.

101 Characterisation of the porosity was conducted on 3 specimens for each configuration on
102 planes perpendicular to the specimen axis (i.e. perpendicular to the building direction). For each
103 configuration, the number of transverse cut planes analysed is between 10 and 20, which result in
104 a total analysed area of between 340 mm² and 1100 mm². The smallest pore that was observed
105 is of approximately 5 µm in diameter. In addition to the porosity characterisations on polished
106 samples, X-ray tomography observations have been conducted on a small sample in order to vi-
107 sualise the 3D geometry of pores. The two types of pores that were observed are gas pores and
108 LoF pores. While gas pores are generally spherical, the LoF pores, related mainly to the balling
109 effect [15], have a very spread-out geometry, i.e. a large area but small thickness. The plane on
110 which pores spread out is generally perpendicular to the building direction. Figure 4 shows the
111 geometries of a gas pore and a LoF pore observed by X-ray tomography. These observations are
112 in a good agreement with the literature [18]. The porosity levels measured on polished samples
113 are very low, approximately 0.001%. The pore density, characterised by the number of pores per
114 mm², is approximately 1.08×10^{-2} pores /mm² for LoF pores. For gas pore, the density is higher,
115 approximately 3.29×10^{-2} pores /mm².

116 Surface roughness characterisations were realised thanks to an optical 3D profilometer on 3
117 specimens for each configuration. A scan of an as-built surfaces by the profilometer is illustrated
118 in Figure 5a and the same zone observed using an Scanning Electronic Microscope (SEM) is
119 shown in Figure 5b.

120 It can be seen that the as-built surface is principally made up of un-melted particles (in red)
121 and valleys in well-melted zones (in dark blue). These singularities are distributed homogeneously

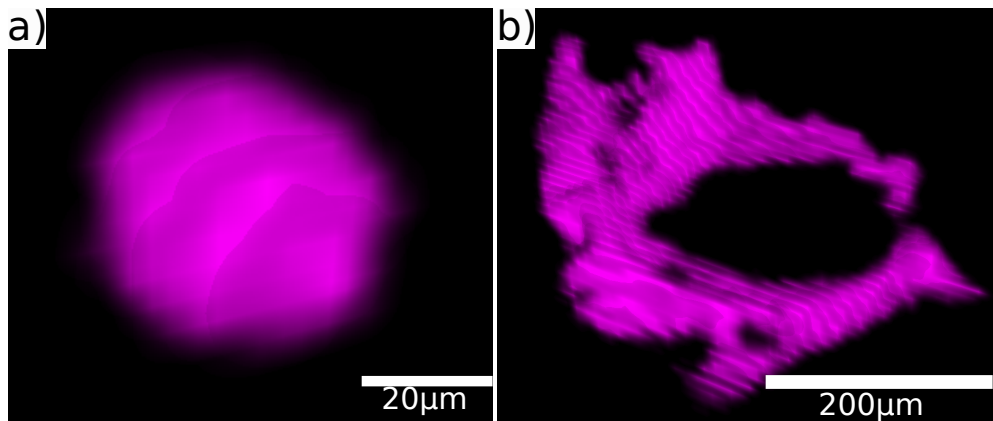

Figure 4: (a) A gas pore and (b) a LoF pore observed by X-ray micro-tomography

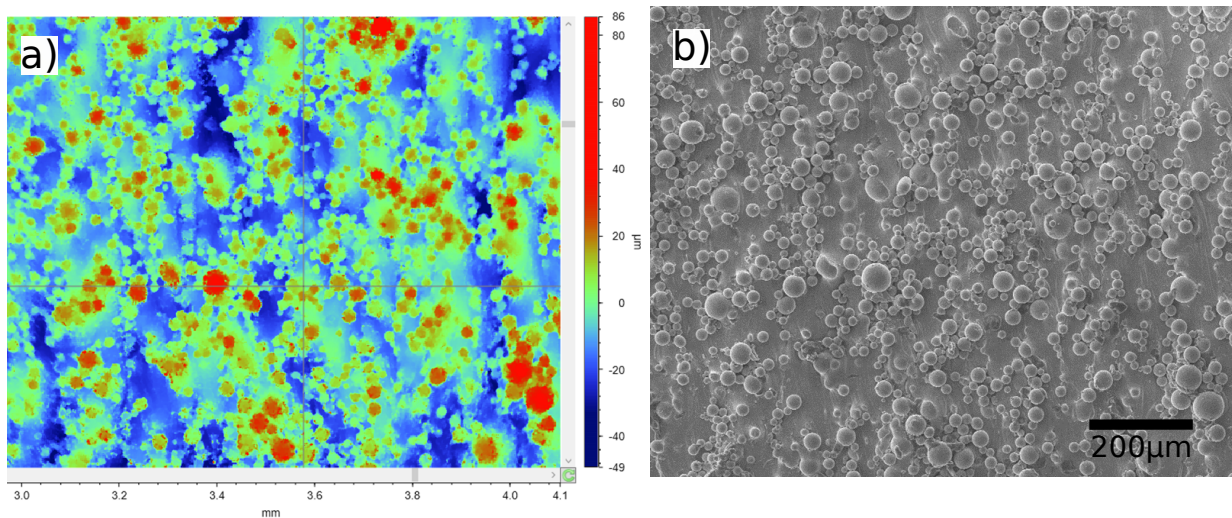

Figure 5: Surface topography of as built specimen (a) Surface scanned by a 3D profilometer; (b)The same surface area observed by a SEM

122 on the specimen surface and no noticeable effect of the gas flux was observed on the surface. The
 123 surface roughness is evaluated in zones with a size of 20 mm \times 1 mm for standard size specimens
 124 and 6 mm \times 1 mm for small size specimens. The 2D surface roughness S_a , defined as the double
 125 integral of the height/depth of peaks are calculated over the evaluation zone after removing the
 126 surface wavelength by using a Gaussian filter with the cut-off wavelength λ_c of 2.5 mm. The
 127 resulting measured S_a values are given in Table 3. It can be seen that the difference in surface
 128 roughness between the standard size specimens and small size specimens is negligible.

129 Quasi-static tensile tests were conducted as per the standard ASTM E8/E8M-13 on flat spec-
 130 imens with a rectangular cross-section of 2 mm × 6 mm. The strain was measured using an
 131 extensometer with an initial length $L_0=25$ mm and a displacement range $\Delta L = \pm 2.5$ mm. All tests
 132 were conducted with a constant strain rate of 0.005 min^{-1} at ambient temperature and environment.
 133 The tensile properties of the investigated materials are given in Table 3.

Configuration	E (GPa)	$\sigma_{y,0.2}$ (MPa)	σ_u (MPa)	A (%)	Sa (μm)	μ -hardness (Hv0.2)
Standard size - Machined	112	849	991	8	<0.5	370
Small size - Machined					<0.5	
Standard size - As-built	103	839	927	13.8	≈ 9.9	440 on surface/
Small size - As-built					≈ 10.5	370 in bulk

Table 3: Tensile properties, surface roughness and micro-hardness of the investigated materials

134 2. Fatigue behaviour and damage mechanisms

135 All fatigue tests were carried out at ambient temperature and pressure in laboratory air. The
 136 fatigue tests were conducted with a constant stress amplitude, a load ratio $R=0.1$ and a frequency
 137 of 20 Hz. A maximum fatigue life of 2×10^6 cycles was used. The reasons for which the fatigue
 138 tests were interrupted at 2×10^6 cycles are: (i) the industrial partners of the project are interested in
 139 the fatigue behaviour for fatigue lives between 10^5 and 2×10^6 cycles; (ii) due to the requirements
 140 of the industrial partners, the testing frequency was limited to 20 Hz; at this frequency, longer
 141 fatigue lives were not possible due to time and budgetary limitations; (iii) as widely shown in the
 142 literature, even at a fatigue life of 2×10^6 cycles, the presence of defects has a pronounced effect
 143 on the fatigue behaviour of additively manufactured metals. The stopping criterion was chosen
 144 to be the complete rupture of the specimen. The run-out specimens that survived 2×10^6 cycles
 145 were re-tested at a higher load. The principal aims of the re-tests is to gain access to the critical
 146 defect for all of the specimens in order to obtain a large enough database with a limited number
 147 of specimens. Because only the specimens that survived 2×10^6 cycles were re-tested, the authors

148 supposed that the strengthening or the cumulative damage is not significant at such a high number
149 of cycles.

150 2.1. Wöhler curves

The experimental results, in the form of Wöhler curves, are shown in Figure 6 for the machined specimens and in Figure 7 for the as built specimens. The fitting curves corresponding to a probability of failure of 10%, 50% and 90% were calculated using the Stromeyer equation, defined as follows:

$$\text{Log}_{10}N_f = C - m \times \text{Log}_{10}(S_{max} - S_0) \quad (1)$$

151 The three parameters in this equation, C , S_0 and m are fitted using the Maximum Likelihood
152 Estimation (MLE) method. It must be to note that the re-tested points were neglected while the
153 run-out points were taken into account in the fitting algorithm. The detail of the algorithm was
154 shown in the work of Pollak et al. [19]. From the fitting equation, the fatigue limit at 2×10^6
155 cycles, S_D , and the associated standard deviation, Std , were calculated.

156 It can be seen that for the machined specimens (Figure 6a and Figure 6b) the scatter in the
157 fatigue data is relatively high with a covariance, Std/SD , between 12% and 16%. Furthermore, it
158 seems that the data is grouped into two different populations. This is especially clear for the small
159 size machined specimens. The first population, on the left of the diagram, includes points with N_f
160 lower than 10^5 cycles even for low applied stresses. The second population on the right includes
161 specimens which have much higher fatigue strength with N_f between 10^5 and 2×10^6 cycles. A
162 comparison with data from the literature [1, 4, 21–23] in Figure 6c shows that the fatigue strength
163 of the investigated material is relatively good. Most of the data points are comparable to the
164 wrought Ti-6Al-4V material. However, the scatter is higher in comparison with the AM data from
165 the literature.

166 For the as-built specimens (Figure 7a and Figure 7b), the scatter in the S-N data is much lower,
167 with a covariance between 5.5% and 8.6%. The comparison with data from the literature [1, 4] in
168 Figure 7c also shows that the fatigue strength of the material in the present investigation is slightly
169 better.

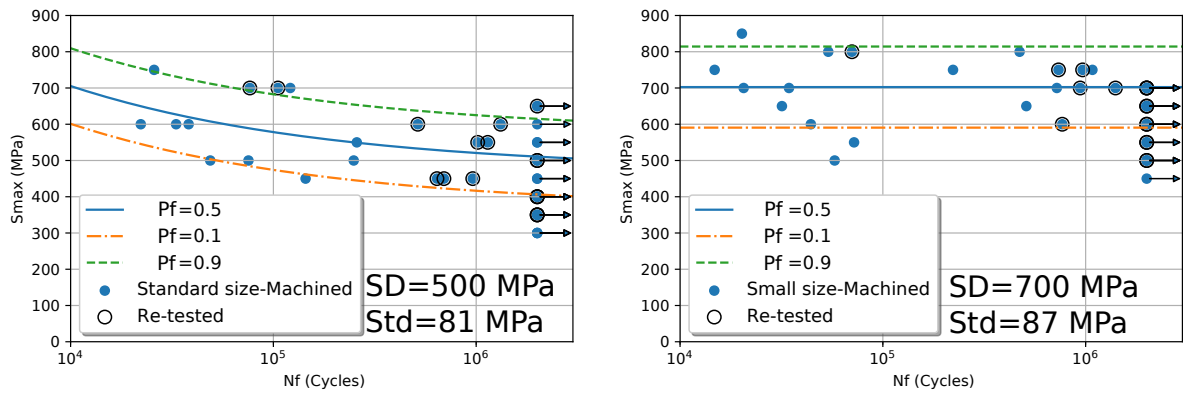

(a) Standard size machined

(b) Small size machined

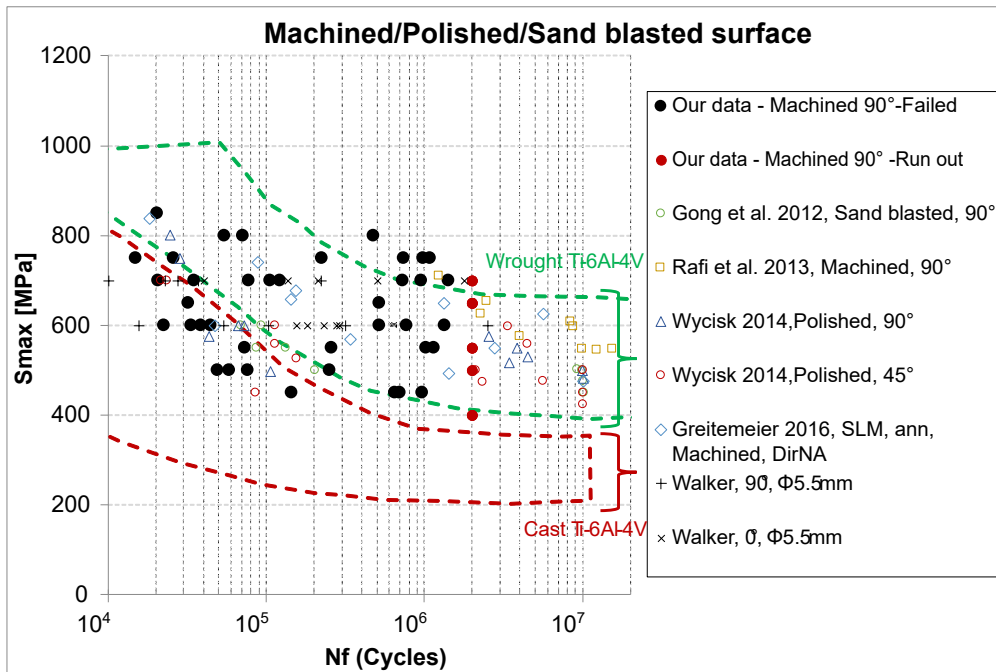

(c) Comparison with the literature

Figure 6: Wöhler curves for (a) standard size machined specimens, (b) small size machined specimens and (c) comparison with data from the literature. The bands for wrought and cast Ti-6Al-4V are from [20] "Titanium: a technical guide"

170 In order to estimate the effect of the as-built surface, a comparison between the as-built and
 171 machined specimens is given in Figure 8. It can be stated that the as-built surface drastically
 172 reduces the fatigue strength of the material: the fatigue strength at 2×10^6 cycles for the as-

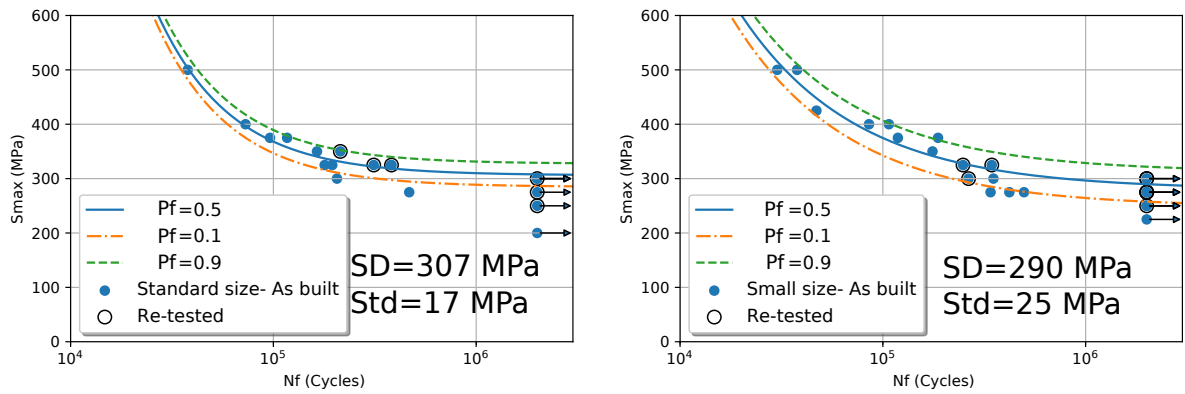

(a) Standard size as-built

(b) Small size as-built

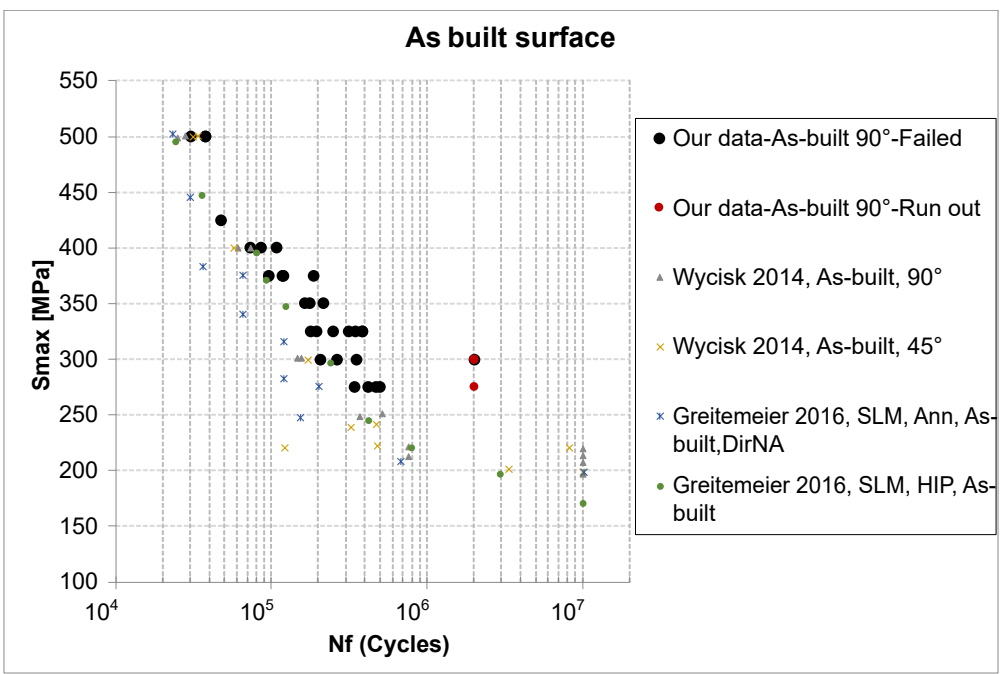

(c) Comparison with the literature

Figure 7: Wöhler curves for (a) as-built standard size specimens, (b) as-built small size specimens and (c) comparison with data from the literature

173 built specimens is approximately 40% to 60% lower than the machined specimens. However,
 174 this comparison shows only a macroscopic view of the effect of the as-built surface while the
 175 fatigue damage mechanisms have not been taken into account. Later in the paper, a detailed
 176 comparison between the machined and as-built specimens for a same crack initiation mechanism

177 will be presented.

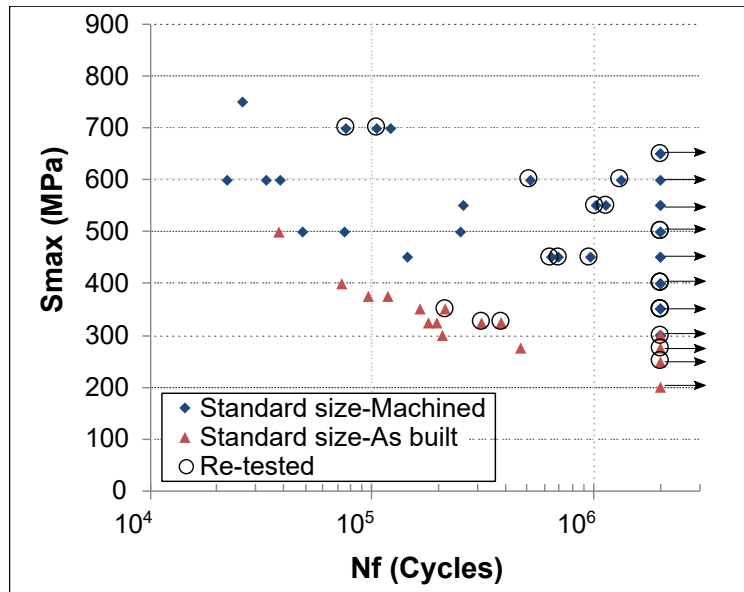

(a) Standard size specimens

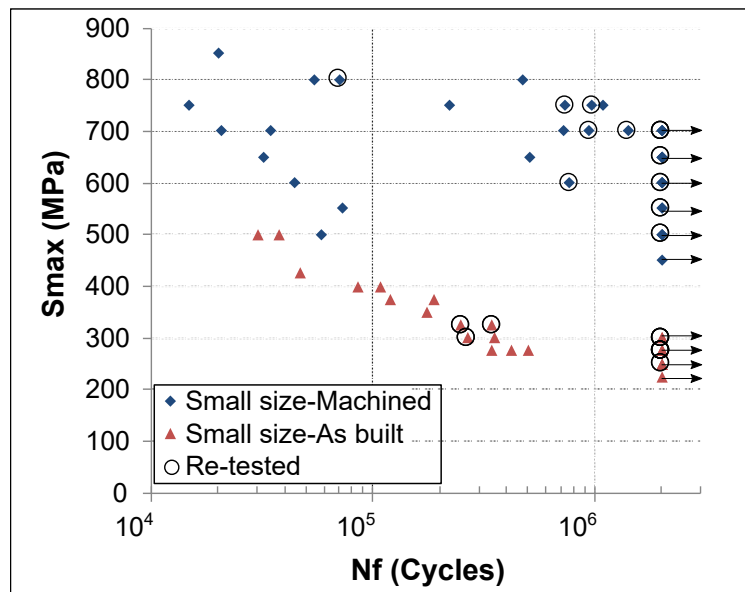

(b) Small size specimens

Figure 8: Comparison between the Wöhler curves for the machined specimens and the As-built specimens for (a) standard size specimens and (b) small size specimens

178 *2.2. Fatigue crack initiation mechanisms*

179 All of the fatigue failure surfaces were analysed using a scanning electronic microscope in
 180 order to identify the origin of crack initiation and to measure the defect size. For the machined
 181 specimens, four crack initiation mechanisms were identified:

- 182 • LoF pores at the free surface (Figure 9a)
- 183 • LoF pores in the bulk (Figure 9b)
- 184 • Gas pores at the free surface (Figure 9c)
- 185 • Gas pores in the bulk (Figure 9d)

186 For the as-built specimens, only the following two crack initiation mechanisms were observed:

- 187 • LoF pores at the free surface (Figure 10a)
- 188 • Surface roughness (Figure 10b), multi-site crack initiation often observed

189 A summary of the crack initiation mechanisms observed in all of the batches is given in Ta-
 190 ble 4. It can be seen that crack initiation from LoF pores at surface is the most likely to occur. The

Geometry	LoF pore on surface	LoF pore in bulk	Gas pore on surface	Gas pore in bulk	Roughness
Standard size machined	10	8	2	0	0
Small size machined	7	5	4	3	0
Standard size As-built	12	0	0	0	2
Small size As-built	7	0	0	0	8

Table 4: A summary of the number of specimens in which the different crack initiation mechanisms were observed for the different specimen types and sizes

190 probability of occurrence of surface LoF pores is between 37% and 85%. For the as-built speci-
 191 mens, neither gas pores nor internal LoF pores were observed at the crack initiation sites. Another
 192 interesting observation that can be made is that the probability of occurrence of LoF pores at the
 193

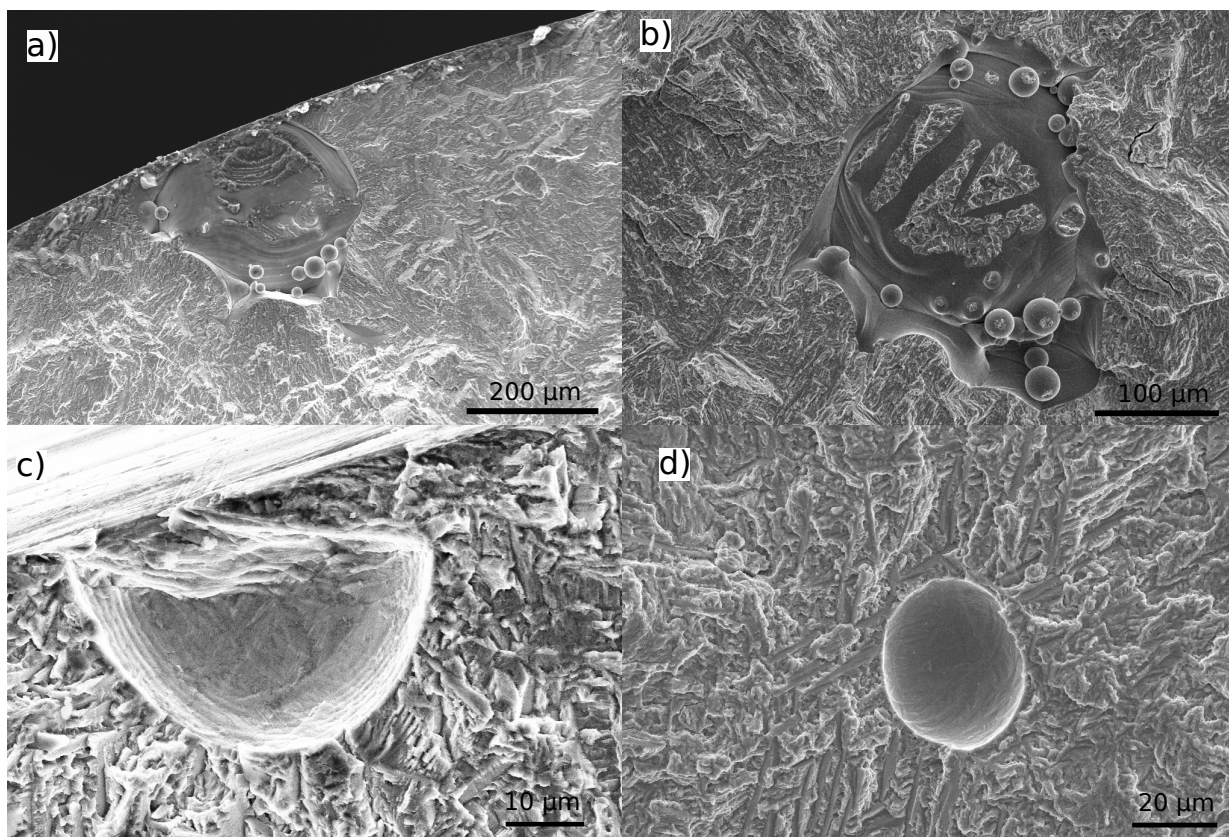

Figure 9: The four defect types observed in the machined specimens at the crack initiation sites: (a) LoF pore at the surface, (b) LoF pore in the bulk, (c) Gas pore at the surface, (d) Gas pore in the bulk

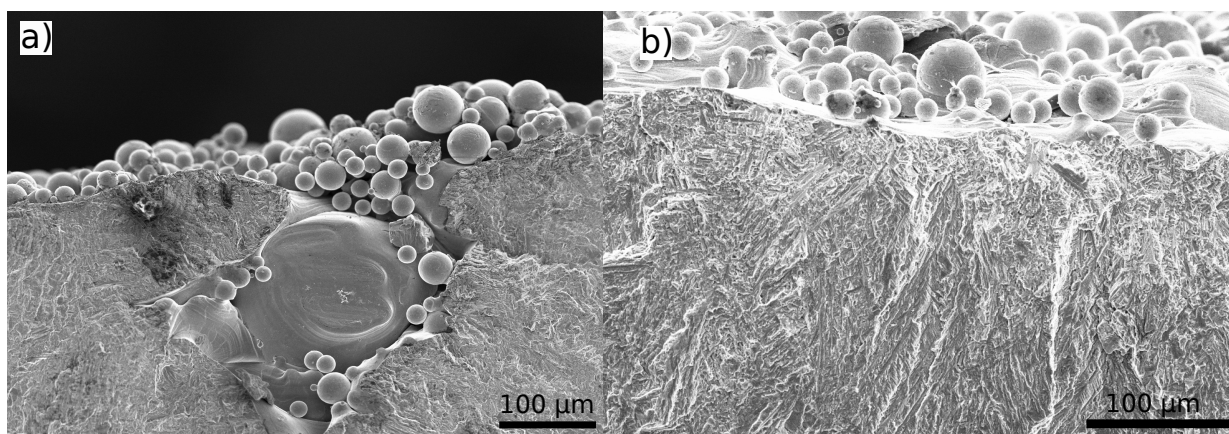

Figure 10: The two crack initiation mechanisms observed at the crack initiation sites: (a) One site crack initiation from a LoF pore at the surface; (b) Multi-site crack initiation from the surface roughness

194 surface for the standard size specimens is higher than for the small size specimens. This is true for
 195 both machined and as-built surfaces. This observation will be analysed more closely in Section 4
 196 with respect to the statistical size effect.

197 The size of all of the critical pores at the crack initiation sites was measured and is expressed
 198 using the square root of the area parameter, \sqrt{area} . Regarding the crack initiation mechanism
 199 related to the surface roughness, in this work no relevant size parameter was found that could
 200 be compared to the \sqrt{area} parameter used for pores. In fact, the surface roughness defects are
 201 generally narrow (with a depth smaller than 50 μm) but very long. For this reason, the area
 202 measure on the failure surface does not seem relevant. Other parameters such as the depth and the
 203 bottom curvature of the local surface valleys might be more significant [24, 25].

The pore size distributions are shown in Figure 11 in terms of the reduced variable, Y_j , as-
 sociated with the Gumbel distribution. The reduced variable is calculated from the empirical
 cumulative density function, F_j , as follows:

$$Y_j = -Ln(-Ln(F_j)) \quad (2)$$

204 The mean value and the standard deviation of the pore size are given in Table 5.

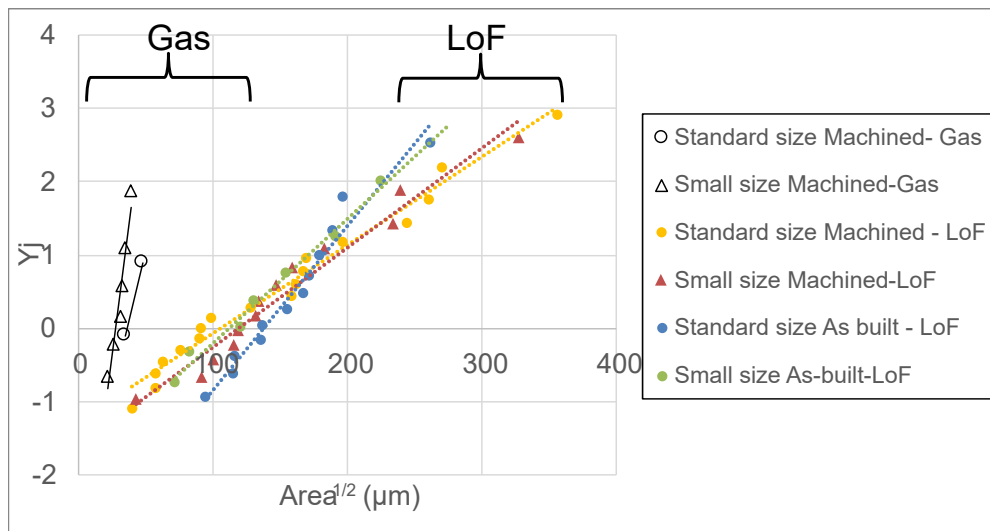

Figure 11: Distributions of the critical pore size measured at the crack initiation sites in a linearized Gumbel space

205 It can be seen that the size of the critical gas pores is generally lower than 50 μm while the
 206 critical LoF pores have a size between 50 μm and 350 μm , with an average value of approximately

Configuration	LoF Pore size	Gas Pore size
	Mean (Std) [μm]	Mean (Std) [μm]
Standard size-Machined	149 (89)	41 (9)
Small size-Machined	156 (75)	31 (6)
Standard size- As-built	160 (45)	-
Small size- As-built	140 (55)	-

Table 5: The mean value and standard deviation of the size of the critical pores observed at the crack initiation sites expressed in terms of their $\sqrt{\text{area}}$

207 150 μm . For the LoF pores, the average pore size is similar in all of the specimen configurations.
208 It means that there is no difference of the LoF pore size between the machined and as-built speci-
209 mens. Also, there is no difference between the standard size specimens and small size specimens.
210 This observation is surprising at first glance because as per the theory of extreme values [26, 27],
211 the maximum pore size in a volume should increase with increasing volume. However, it was
212 shown in the work of El Khoukhi et al. [28] that there is a threshold in terms of loaded volume,
213 beyond which the critical pore size does not change with increasing volume. The authors showed
214 that the value of this threshold depends on different factors such as the pore size distribution and
215 the inter-pores distance. Thanks to this result, it can be assumed that the "threshold" volume
216 related to LoF pore distribution has already been reached even with the small size specimens.

217 **3. Links between the fatigue strength and crack initiation mechanisms**

218 In this section, the relationship between the crack initiation mechanisms and the fatigue be-
219 haviour will be quantitatively characterised. More precisely, the S-N curves will be analysed
220 separately for each crack initiation mechanism. The pore size is also taken into account by using a
221 "corrected stress" parameter. Thanks to these analyses, two important questions will be answered:

- 222 • What is the effect of the size and the spatial position of the pores?
- 223 • What is the effect of the as-built surface? For the same crack initiation mechanism from
224 pores, is there a difference between the machined and the as-built specimens.

225 *3.1. Machined specimens*

226 Figure 12 shows the S-N data for the machined specimens, in which the different crack initiation mechanisms are highlighted. The different initiation mechanisms can be ranked qualitatively

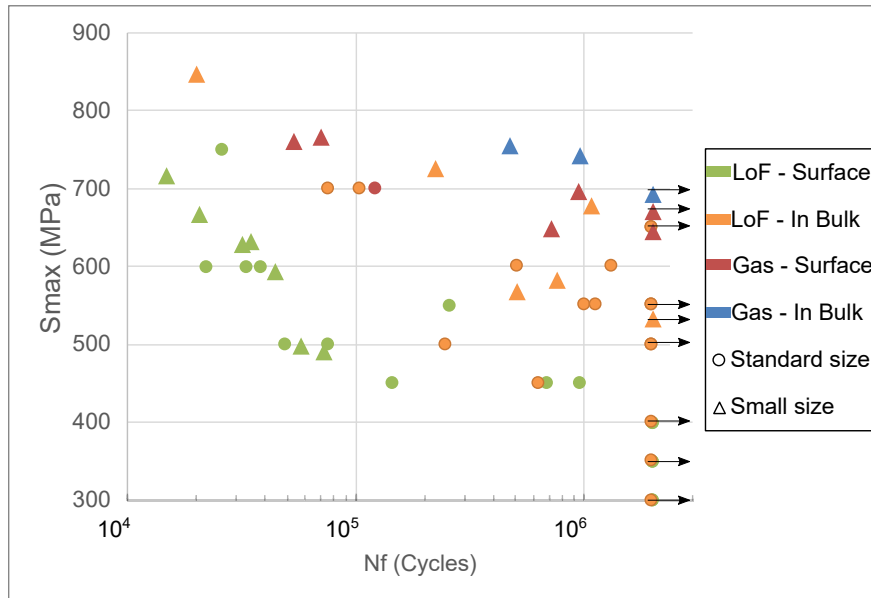

Figure 12: Correlation between the fatigue strength and the fatigue damage mechanisms for the Machined specimens. Note that the small size specimens do not have a constant gauge section. For these specimens the applied stress is calculated at the crack position which does not necessarily correspond to the smallest diameter.

227

228 in terms of which mechanism is the most detrimental or harmful:

229 1- LoF pores at the surface (the most detrimental)

230 2- LoF pores in the bulk

231 3- Gas pores at the surface

232 4- Gas pores in the bulk (the least detrimental)

233 It is interesting to note that, for the investigated material, a large internal LoF pore (with an average
 234 size of 150 μm - Table 5) can be more detrimental than a small surface gas pore (with an average
 235 size of 30 μm). Regarding the two populations of the fatigue strength mentioned earlier in Sec-
 236 tion 2.1, the population with low fatigue strength is related to the presence of a critical LoF pore
 237 at the surface while the second population with higher fatigue strength but greater more scatter, is
 238 related to the three other damage mechanisms: LoF pores in bulk, Gas pores on surface and Gas

239 pores in bulk.

240 3.2. As-built specimens

241 For the as-built specimens, Figure 13 shows the S-N diagram in which the two crack initiation mechanisms are highlighted. It can be seen that there are no significant difference in terms of

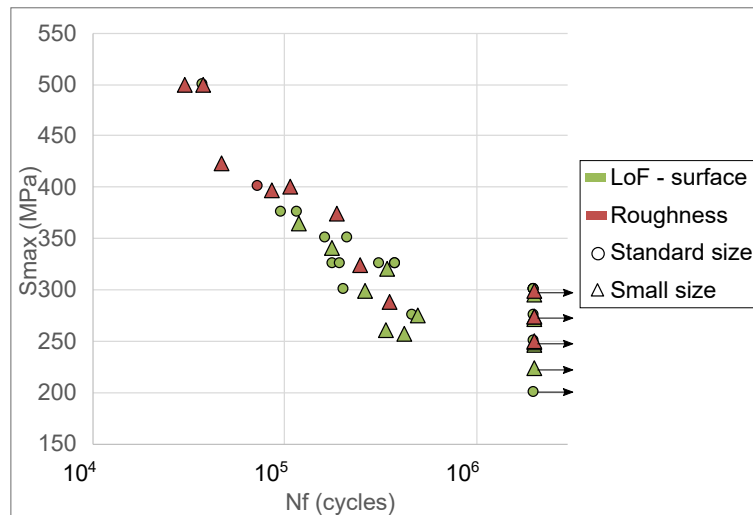

Figure 13: Correlation between the fatigue strength and the fatigue damage mechanisms of the As-built specimens. Note that for the small size specimens the applied stress is calculated using the diameter at the crack position and not the diameter at the smallest section.

242
243 the fatigue strength between crack initiation from LoF pores at the surface and crack initiation
244 from surface roughness. This observation is quite surprising because when linked to the defect
245 size as illustrated in Figure 10, the impact of a LoF pore with a depth of approximately 400 μm
246 (Figure 10a) is equivalent to a surface roughness defect with a depth of 20 μm (Figure 10b). One
247 possible explanation is that the defect aspect ratio, i.e. the ratio between the depth and the length
248 on the surface, is much lower for roughness defects than for LoF pores. According to Molaei et
249 al. [29], the aspect ratio greatly influences the fatigue strength and hence the defect depth alone
250 or the defect area alone are not adequate to fully characterise the effect of the roughness defects.
251 Another factor may also affect the fatigue strength of as built specimens is the sub-surface layer
252 with a more brittle microstructure, as discussed in Section 1.2. The effect of defect size may be
253 less pronounced than for the machined specimens. This hypothesis will be discussed again in the

254 comparison of the effect of the LoF pores between the machined surface and as-built surface in the
255 next section.

256 3.3. Analysis of S-N data taking into account the crack initiation mechanism and the critical pore 257 size

In this section, the S-N data will be analysed separately for each crack initiation mechanism. The pore size will also be taken into account in this analysis by using the approach developed in the previous work [15]. This approach, inspired by the work of Caton et al. [30], introduce a "Corrected stress S_{max} " in which the critical pore size is taken into account, as given in Equation (3). More details related to this approach can be found in previous work published by the authors [15].

$$\text{Corrected } S_{max} = S_{max} \left(\frac{\sqrt{area}}{\text{average}(\sqrt{area}_i)} \right)^{s'} \quad (3)$$

258 The two parameters used in this formula, average (\sqrt{area}_i) and s' , are determined as follows:

- 259 • Average (\sqrt{area}_i): the average pore size for each defect category. For LoF pores, the mean
260 pore size is 150 μm . For gas pores, the mean pore size is 30 μm . The main reason for using
261 the mean pore size is to make it possible to compare the corrected data with the uncorrected
262 S-N curves.
- s' : a non-linear weight factor related to the pore size. Higher values of s' result in a more
pronounced effect of the porosity. In this work, the parameter s' is identified by using the
MLE method in which the Stromeyer equation was used to fit the S-N data.

$$\text{Log}_{10}N = C - m \times \text{Log}_{10}(\text{Corrected } S_{max} - S_0) \quad (4)$$

263 In short, the four parameters of the model optimised by the MLE method are s' , C , m and S_0 ,
264 compared to the 3 parameters when using the classical Stromeyer equation as in Section 2.1.

265 Figure 14 and Figure 15 show the corrected S-N diagram in comparison with the uncorrected
266 S-N diagram for the machined and the as-built specimens. The identified parameters are given
267 in Table 6. It should be noted that for the mechanism related to gas pore in the bulk for the
268 machined specimens, the MLE estimation was not possible due to the limited number of data.

269 Only the fatigue strength was estimated in order to compare with the other mechanisms. For better
270 understanding the comparability between the corrected and uncorrected S-N diagrams, it should
271 be noted that for a pore size equal to the average pore size (as a reminder 150 μm for LoF pores and
272 30 μm for LoF pores), the fitting curves presented in the corrected stress diagrams are unchanged
273 when presented in the uncorrected stress diagrams. Similarly, the estimated fatigue strengths in
274 terms of corrected stress shown in Table 6 are unchanged when calculated for uncorrected stress
275 with a pore size equal to the average pore size.

276 By using the corrected stress that takes into account the pore size, it can be seen that the scatter
277 of the S-N can be reduced, especially for machined specimens. In comparison with the raw S-N
278 curves without regarding neither crack initiation mechanism nor critical defect size (Figure 6), the
279 covariance Std/Sd of all of the corrected Smax-Nf are lower than 10%, compared with a covariance
280 up to 16% for raw Smax-Nf curves.

281 For machined specimens, it can be seen in Figure 14a that no significant statistical size effect
282 is observed when the surface LoF pores govern the fatigue crack initiation. In fact, the fatigue
283 strength is similar between the standard size and the small size specimens. However, for LoF
284 pores in the bulk (Figure 14b), a slight effect can be seen. For mechanisms related to gas pores
285 (Figure 14c, Figure 14d), no clear difference can be observed between the standard and small
286 specimens. This observation can be explained by the similar pore size distributions between the
287 standard and small specimens as shown in Figure 11. From this analysis, it can be concluded that
288 the size effect observed for the machined specimens (Figure 6) cannot be clearly explained by
289 analysing the critical pore size. A more detailed discussion is proposed in Section 4.

290 Thanks to the estimated fatigue strength at 2×10^6 cycles, the Kitagawa-Tagahashi diagram for
291 average defect sizes and mean fatigue strength can be drawn as shown in Figure 16. The horizontal
292 fatigue limit at 2×10^6 cycles is estimated to be 700 MPa from the literature [4, 31, 32] for the
293 AM Ti-6Al-4V alloy with a Hot Isostatic Pressing (HIP) treatment. For the LEFM prediction, a
294 value of the stress intensity factor threshold $\Delta K_{th} = 3.9 \text{ MPa} \sqrt{m}$ is used. This value is found in
295 the work of Leuders et al. [33] and corresponds to the SLM Ti-6Al-4V alloy fabricated in the
296 90° building direction and a post HIP treatment. The Kitagawa-Takahashi diagram shows that,
297 for the machined specimens, the difference between surface LoF Pores and internal LoF pores is

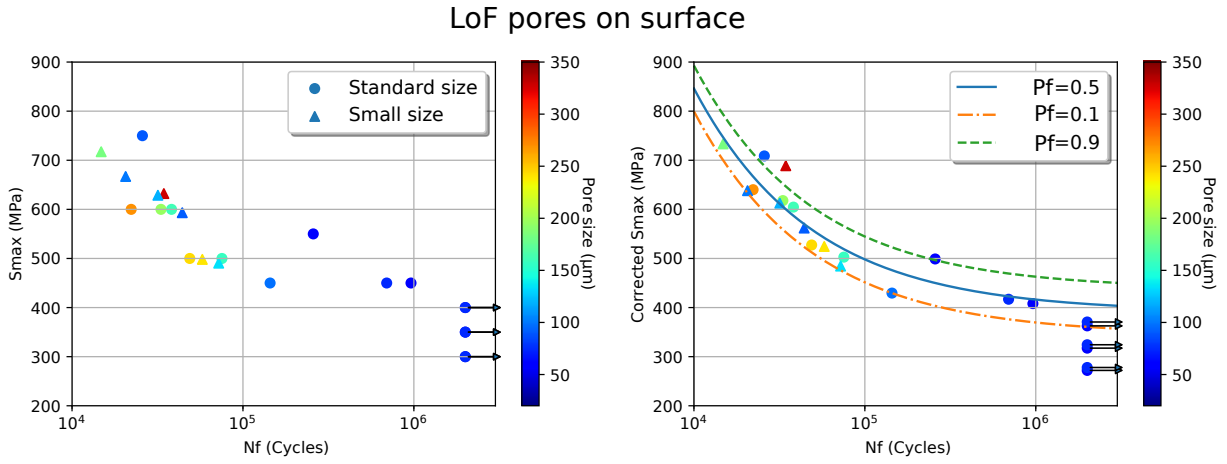

(a) LoF pores on surface-Corrected $S_{max} = S_{max} \times (\sqrt{\text{area}}/150)^{0.11}$

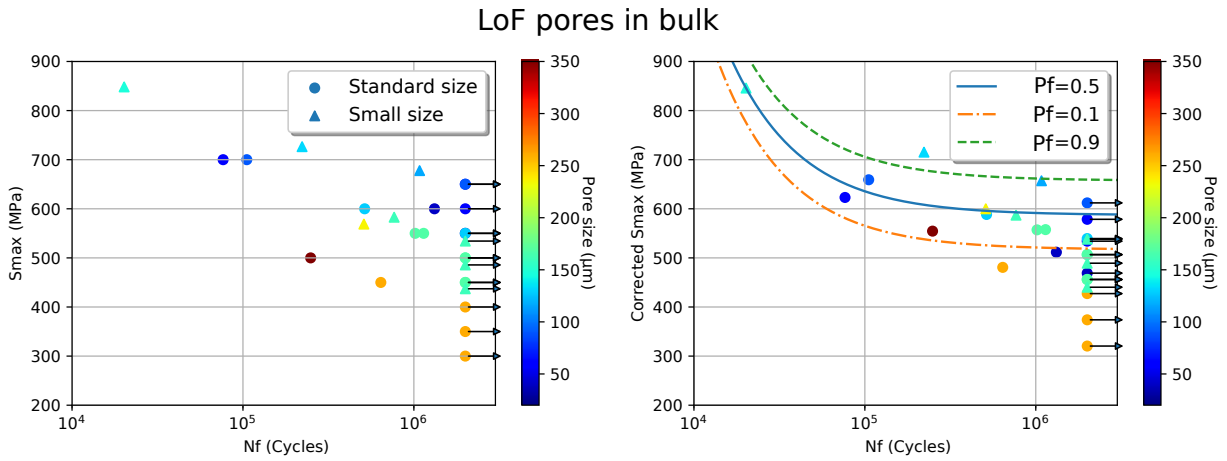

(b) LoF pores in bulk-Corrected $S_{max} = S_{max} \times (\sqrt{\text{area}}/150)^{0.12}$

Figure 14: Uncorrected and Corrected S-N curves of machined specimens for the crack initiation mechanism related to: (a) LoF pores on surface; (b) LoF pores in bulk

298 notable: the fatigue strength associated with internal LoF pores is approximately 44% higher than
 299 for surface LoF pores. In terms of fatigue life, it can be seen in Figure 14a and Figure 14b that, at a
 300 corrected stress of 600 MPa, the fatigue life corresponding to internal LoF pores is approximately
 301 10 times greater than surface LoF pores. The classical Murakami approach [34] which makes
 302 a distinction between surface and internal defects is not good enough to accurately predict this
 303 difference. In fact, by using a geometry factor of 1.43 for surface defects and 1.56 for internal

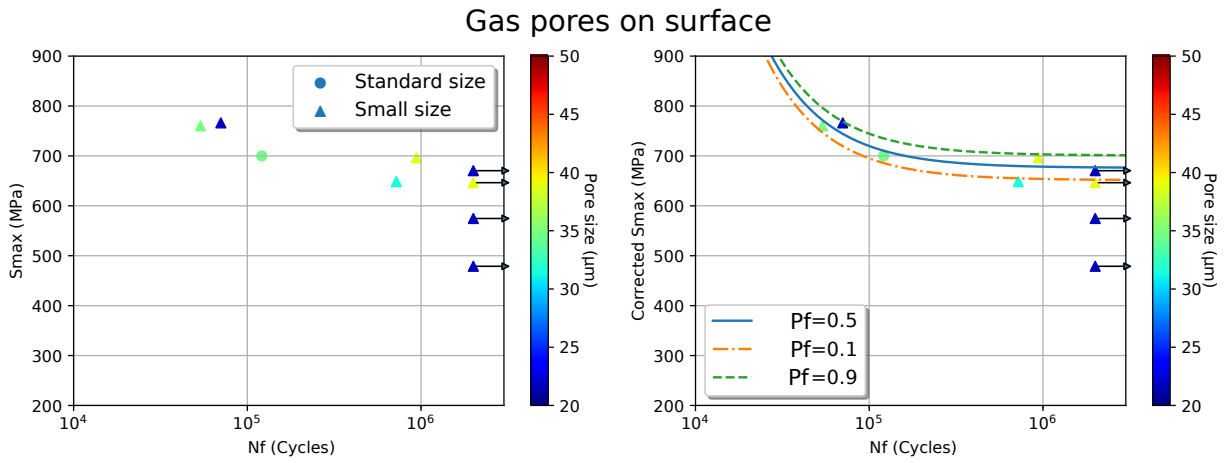

(c) Gas pores at the surface-Corrected $S_{max} = S_{max} \times (\sqrt{area}/30)^0 = S_{max}$

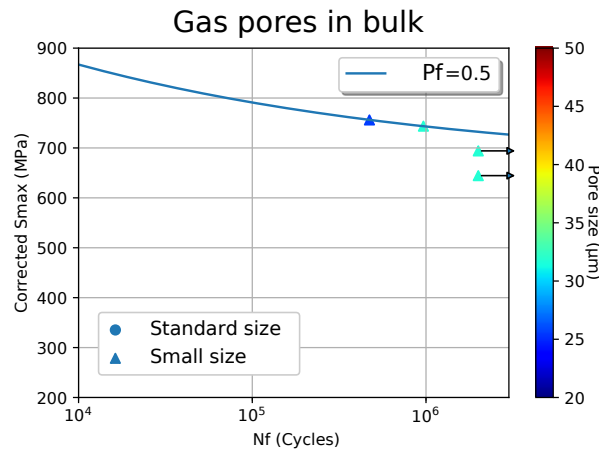

(d) Gas pores in the bulk-Corrected $S_{max} = S_{max} \times (\sqrt{area}/30)^0 = S_{max}$

Figure 14: (Continued) Uncorrected and Corrected S-N curves of machined specimens for the crack initiation mechanism related to: (c) Gas pores on surface; (d) Gas pores in bulk

304 defects, the Murakami approach predicts a factor of 1.1 between the fatigue limits of internal and
 305 surface defects while in the present work, a factor of 1.44 is observed. This result is in good
 306 agreement with the work of Andreau et al. [35] which showed, for a SLM 316L alloy having a
 307 polished contour, that internal defects must have a size of 4 to 10 times greater than surface defects
 308 to become critical in fatigue. A lower crack growth rate from internal defects compared to surface
 309 defects, as shown in the work of Junet el al. [36] for Ti-6Al-4V alloy or in the work of Serrano-

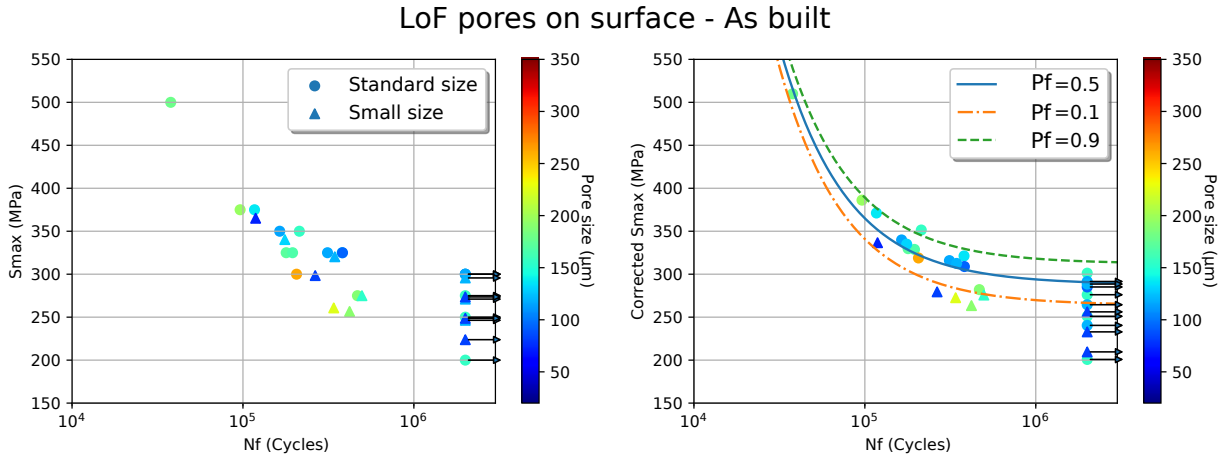

(a) LoF pores on surface-Corrected $S_{max} = S_{max} \times (\sqrt{area}/150)^{0.11}$

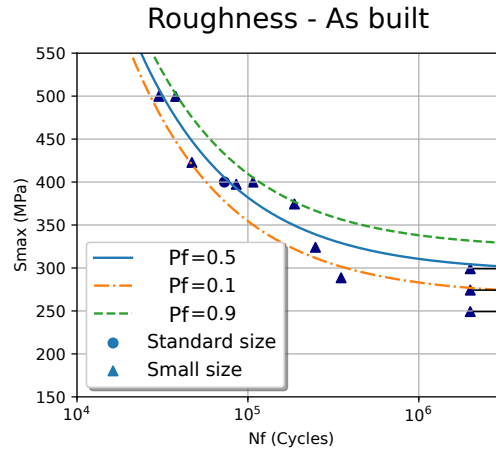

(b) Roughness

Figure 15: (a) Uncorrected and Corrected S-N curves of as-built specimens for the crack initiation mechanism related to LoF pores on surface; (b) Uncorrected S-N curves of as-built specimens for the crack initiation related to surface roughness

310 Munoz et al. [37] for a cast aluminium alloy, also contributes to a higher fatigue strength for the
 311 internal LoF pore related mechanism. It can also be stated that the classical LEFM approach with
 312 a value of $\Delta K_{th} = 3.9 \text{ MPa} \sqrt{m}$ under-estimates the fatigue strength related to the surface LoF
 313 pores mechanism for machined specimens. For as built specimens, the prediction seems better.
 314 However, it must be kept in mind that the effect of several factors such as the interaction with the
 315 surface roughness or the effect of the sub-surface layer is not fully understood.

Mechanism	Corrected Smax formula	m	C	S_0	Fatigue strength (corrected Smax) at 2×10^6 cycles	
					Mean (MPa)	Std (MPa)
Machined - LoF on surface	$S_{max} \times \left(\frac{\sqrt{area}}{150}\right)^{0.11}$	-1.6	8.2	391	407	36
Machined - LoF in bulk	$S_{max} \times \left(\frac{\sqrt{area}}{150}\right)^{0.12}$	-0.95	6.6	587	589	55
Machined - Gas on surface	$S_{max} \times \left(\frac{\sqrt{area}}{30}\right)^0$	-0.79	6.3	676	677	19
Machined - Gas in bulk	$S_{max} \times \left(\frac{\sqrt{area}}{30}\right)^0$	N/A	N/A	N/A	732*	N/A
As-built - LoF on surface	$S_{max} \times \left(\frac{\sqrt{area}}{150}\right)^{0.11}$	-0.9	6.7	288	290	18.8
As-built - Roughness	Raw S_{max}	-1.33	7.6	295	304	21.4

Table 6: Identified parameters for Equation (4) and the fatigue strength at 2×10^6 cycles corresponding to each mechanism. (*: Estimated value without MLE optimisation)

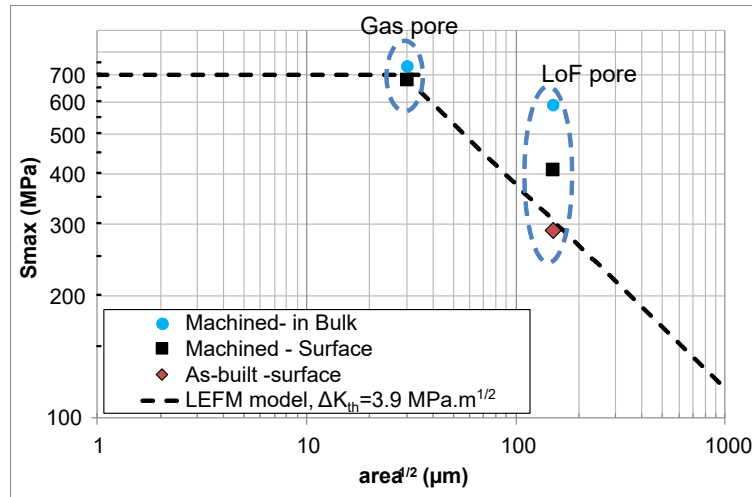

Figure 16: Kitagawa-Takahashi diagram at $N_f = 2 \times 10^6$ cycles

316 Concerning gas pores, the difference between surface and internal pores seems less pronounced.
317 Also, the exponent identified in the S-N analysis, s' , is close to zero. This implies that the effect
318 of the gas pore size, in the range of 30 μm to 50 μm of \sqrt{area} , on the fatigue behaviour is not
319 significant. In fact, comparison with HIPed Ti-6Al-4V alloys shows that the size of gas pores is
320 probably located on the horizontal region of the Kitagawa-Takahashi diagram in which the pore
321 size does not have an impact on the fatigue strength. Even though these defects can be found at the

322 origin of crack initiations, their size is not large enough to significantly reduce the fatigue strength.

323 For the as-built specimens, it can be seen (Figure 15) again that the fatigue strength at 2×10^6
 324 cycles related to the LoF pores at the surface is similar to the fatigue strength associated to the
 325 surface roughness. As mentioned earlier, in order to precisely characterise the effect of the as-built
 326 surface on the fatigue strength, the comparison between the S-N curves including only specimens
 327 with crack initiation from surface LoF pores is shown in Figure 17. Regarding the corrected S-
 328 N curves, the same correction factors (Equation (3)) are used for the machined and the as-built
 329 specimens.

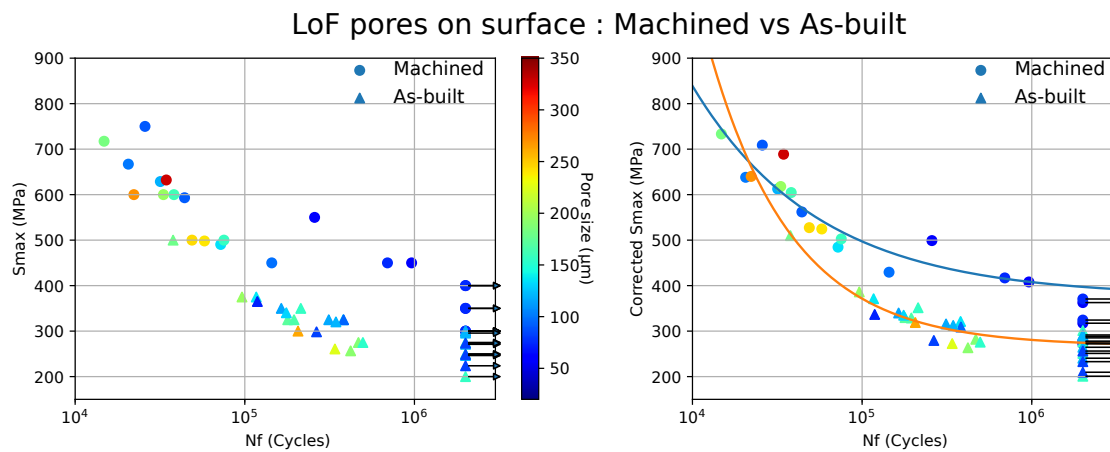

Figure 17: Uncorrected and Corrected S-N curves of machined and as-built specimens for the crack initiation mechanism related to the LoF pores on surface. Corrected $S_{max} = S_{max} \times (\sqrt{area}/150)^{0.11}$

330 It can be seen that for the same critical pore size, the fatigue strength at 2×10^6 cycles for
 331 the as-built specimens is approximately 30% lower than for the machined specimens (290 MPa
 332 vs 407 MPa). For higher stress levels with a life less than 10^5 cycles, the difference attenuates.
 333 As discussed earlier, the coarse alpha lathes of the sub-surface microstructural layer (shown in
 334 Section 1.2) may be one possible explanation for this difference since it is widely known that
 335 a coarse microstructure can reduce the fatigue strength of metallic materials. Also, the higher
 336 micro-hardness of the sub-surface microstructural (Table 3) layer may be related to greater brit-
 337 tleness of the layer and hence, with the presence of pores, a decrease in the fatigue strength. It is
 338 also possible that the interaction between surface pores and the roughness could facilitate crack
 339 initiation from pores. In order to clearly identify the origin of the effect of the as-built surface,

340 further experimental investigations should to be done.

341 **4. Discussion of the statistical scale/size effect**

342 *4.1. Origin of the size effect*

343 It was seen earlier in Figure 6 that, for the machined specimens, if the S-N curves are pre-
344 sented without making the distinction between the different crack initiation mechanisms, the fa-
345 tigue strength at 2×10^6 cycles of the small size specimens is higher than the standard size speci-
346 mens (700 MPa vs 500 MPa). On the contrary, the analysis of S-N curves separately for each crack
347 initiation mechanism in Section 3.3 showed no or very slight size effect due to the similar critical
348 pore size distributions of the standard and small specimens, as shown in Section 2.2. Therefore,
349 it can be concluded that the observed size effect between the standard and small specimens can
350 not be explained by the analysis of critical pore size distributions in this work. In order to better
351 understand the origin of the observed size effect, the probability of occurrence of each crack initi-
352 ation mechanism is calculated from Table 4 and shown in Figure 18. The total volume indicated in
353 Figure 18b corresponds to the $V_{80\%}$ volume (i.e. the highly loaded volume in which the minimum
354 stress is equal to the 80% of the highest stress in the whole specimen) under uniaxial tension loads.

355
356 It can be seen that for the machined specimens, the probability of occurrence of LoF pores
357 is higher for the standard size specimens than for the small size specimens. The probability of
358 occurrence of gas pores is greater for the small size specimens. Because the fatigue strength related
359 to gas pore mechanisms is much higher than for the LoF pore mechanisms, it can be concluded
360 that the size effect observed for the machined specimens is linked principally to the change of the
361 crack initiation mechanism and not to the change of the critical pore size.

362 For the as-built specimens, a change of crack initiation mechanisms can also be seen in Fig-
363 ure 18. The probability of occurrence of LoF pores for the standard specimens is much higher than
364 for the small specimens, and inversely, the probability of failure from surface roughness is higher
365 for the small specimens. However, because of the similar fatigue strengths relative to these two
366 crack initiation mechanisms as shown in Section 3.3, the size effect is much less pronounced for
367 as-built specimens.

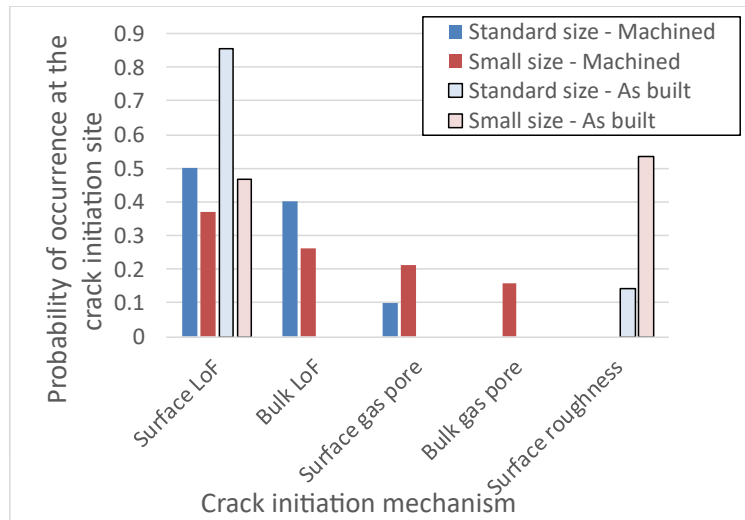

(a) Probability of occurrence of each mechanism at the crack initiation sites

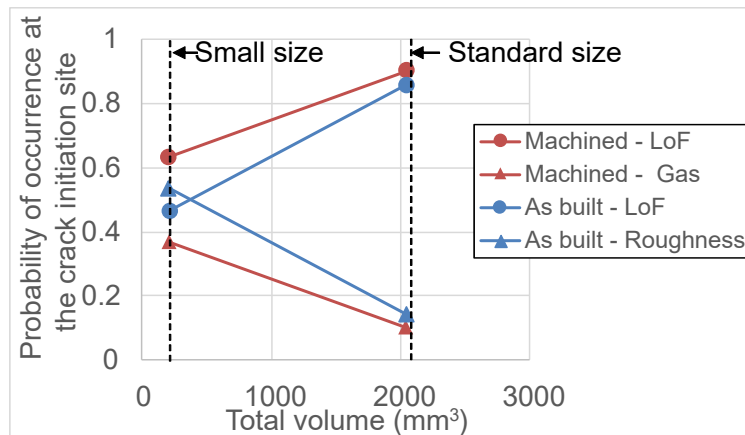

(b) Relationship between the probability of occurrence and the effective volume

Figure 18: Effect of the loaded volume on the probability of occurrence of crack initiation mechanisms

368 *4.2. A first step towards modelling the statistical size effect*

369 It was shown in the previous section that the size effect observed for machined specimens is
 370 governed principally by the change of the crack initiation mechanisms, from the LoF pore related
 371 mechanism to the gas pore related mechanism. Because the LoF pores are the most critical defects,
 372 regardless their spatial position (at the surface or in the bulk), it can be concluded the size effect
 373 observed in this work can be linked to the presence or not of the LoF pore in the loaded volume.

374 From this point of view, the aim of this section is to propose a probabilistic approach to predict
 375 the probability of occurrence of critical LoF pores in a given loaded volume. The pore size distri-
 376 bution is, for this very first step, excluded in the modelling approach. The only input necessary in
 377 the model is the average LoF pore density, λ (i.e. the number of pores per mm^3). It is important
 378 to note that this pore density corresponds to the critical LoF that can decrease the fatigue strength.
 379 From the Kitagawa-Takahashi shown in Figure 16, the estimated minimum size of critical LoF
 380 pore is approximately of $30 \mu\text{m}$. Hence the pores with size smaller than $30 \mu\text{m}$ should not be taken
 381 into account.

382 4.2.1. Modelling framework

383 The approach is based on the work of Chandran [38]. By assuming that the spatial distribution
 384 of the LoF pores is a completely random process, the probability of occurrence of a number (n) of
 385 defects in an arbitrary volume V follows the Poisson distribution. The probability is given by:

$$P(n) = \frac{e^{-\lambda V} (\lambda V)^n}{n!} \quad (5)$$

386 Whether a specimen will fail by a surface LoF pore or an internal LoF pore is decided based
 387 on the following premise: (1) if there is at least one LoF pore in volume V with no LoF Pore in
 388 sub-surface volume V_{sub} , then the specimen fails due to the internal LoF pore; (2) If there is at
 389 least one LoF pore on surface, then the specimen fails due to the surface LoF pore.

390 Firstly, the probability of occurrence of crack initiation from internal LoF pores (premise (1)),
 391 P_{int} , is the conditional probability that one or more LoF pore will occur in volume V with no such
 392 defect present in V_{sub} :

$$P_{int} = (1 - e^{-\lambda(V-V_{sub})})e^{-\lambda V_{sub}} \quad (6)$$

393 The probability of fatigue failure due to a surface LoF pore is given by:

$$P_{surf} = 1 - e^{-\lambda V_{sub}} \quad (7)$$

If no LoF is present in the loaded volume, then the specimen can fail due to the gas pores. The

probability of the absence of LoF in volume V pore is given by:

$$P_{nLoF} = e^{-\lambda V} \quad (8)$$

394 Now, the loaded volume V and the surface volume V_{sub} must be defined. In general, crack
395 initiation occurs in the highly loaded volume in which the minimal stress is higher than 80% of
396 maximum stress [28, 39], or the so-called $V_{80\%}$ volume. For the sub-surface volume, V_{sub} , the
397 volume of a surface annular ring can be used, as proposed in the work of [28, 40]. The thickness
398 of the annular sub-volume is assumed to be the maximum feret diameter of LoF pores measured
399 on the failure surfaces (500 μm in the present work) so that all of the surface LoF pores at the
400 crack initiation site are located entirely in the annular sub-volume.

401 4.2.2. Identification of the LoF pore density

402 The volumetric pore density of LoF pores, λ , is characterised by the number of pores per mm^3 .
403 This pore density can be measured by X-ray micro-tomography on a sufficiently large sample
404 sizes that has not be done in the present work. It is to note that the tomography observation
405 shown in Figure 4 was realized on a very small sample. This observation is only for visualisation
406 purpose but not large enough for statistical analysis. Regarding the pore densities characterised
407 on polished samples in Section 1.2 for surface density (i.e. number of pores per mm^2), it needs to
408 be extrapolated to the volumetric density. Even though some extrapolation methodologies found
409 in the literature such as the classical Murakami methodology [27] have been tried, no relevant
410 methodology was found for the material under investigation. Hence, instead of using experimental
411 measurements, an inverse method is used to determine the critical LoF pore density as follows.

412 The probabilities of occurrence of LoF pores on the surface, P_{surf} , of LoF pores in the bulk,
413 P_{int} , or of no LoF pores in the volume, P_{nLoF} , are calculated for a large range of LoF pore densi-
414 ties. The probabilities of occurrence of critical LoF pores on the failure surfaces are then used to
415 identify the pore density, as shown in Figure 19.

416 It can be seen that, by increasing the LoF pore density, the P_{surf} increases while the P_{int} and
417 P_{nLoF} decrease. By comparison with the experimental data (circular dots), i.e. the probability of
418 occurrence at the crack initiation sites of each mechanism calculated from Table 4, the critical LoF

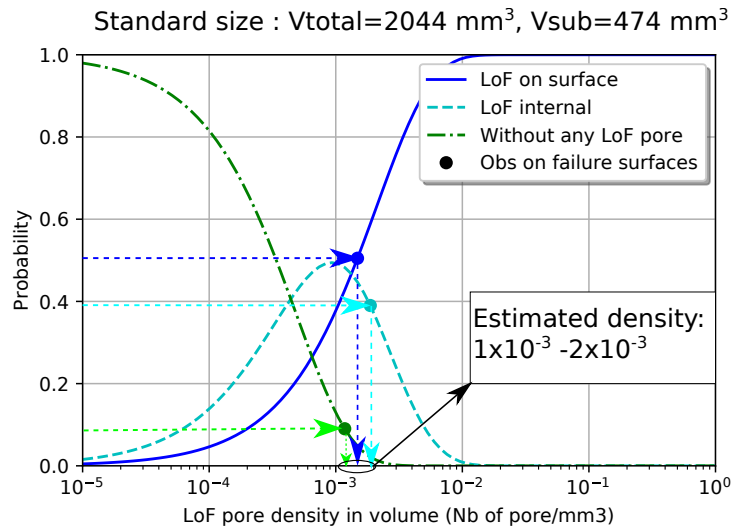

(a) Standard size specimen

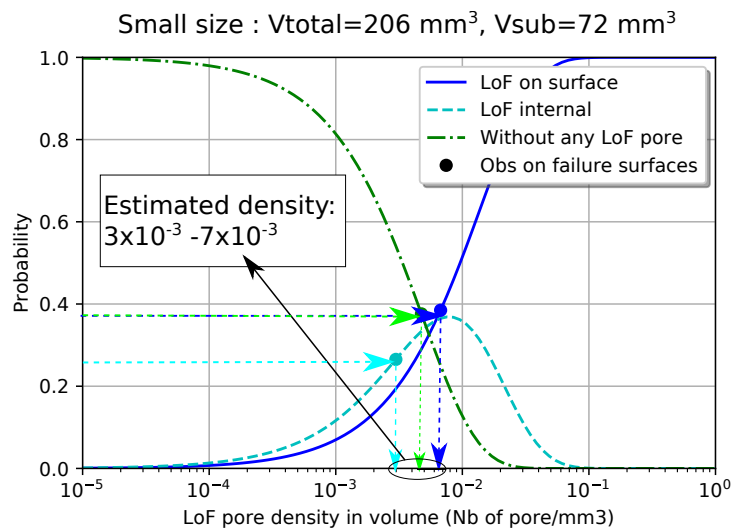

(b) Small size specimen

Figure 19: Evolution of the probabilities of occurrence of LoF pores as a function of the LoF pore density and correlation with the experimental data determined on the fatigue surfaces for (a) standard size specimens and (b) small size specimens

419 pore densities, λ , can be estimated to be between 1×10^{-3} and 2×10^{-3} pores/ mm^3 for the standard
 420 size specimens. For small size specimen data, the critical LoF pore density is between 3×10^{-3}
 421 and 7×10^{-3} pores/ mm^3 . However, it must be kept in mind that this estimation does not take into
 422 account the probabilistic aspect of the experimental data due to the limited number of specimens.

423 4.2.3. Useful tools for process qualification and fatigue design

424 It can be seen in Figure 19a that the maximum allowed LoF pore density is approximately
425 4×10^{-4} pores/mm³ to obtain a probability of occurrence of surface LoF pores lower than 10% for
426 standard size specimens (with a $V_{sub} = 474$ mm³). For small size specimens (Figure 19b) with a
427 $V_{sub} = 72$ mm³, the maximum allowed LoF pore density is approximately 2×10^{-3} pores/mm³.
428 This way of analysis can be useful in the qualification phase of the fabrication process concerns
429 the allowed LoF pore density to guarantee the quality of manufactured components.

430 Another interesting analysis is the evolution of the probability of occurrence of surface LoF
431 pores versus the sub-surface volume shown in Figure 20 for a LoF pore density range of 1×10^{-3}
to 7×10^{-3} pores/mm³. It can be seen that, by increasing the volume, the occurrence probabili-

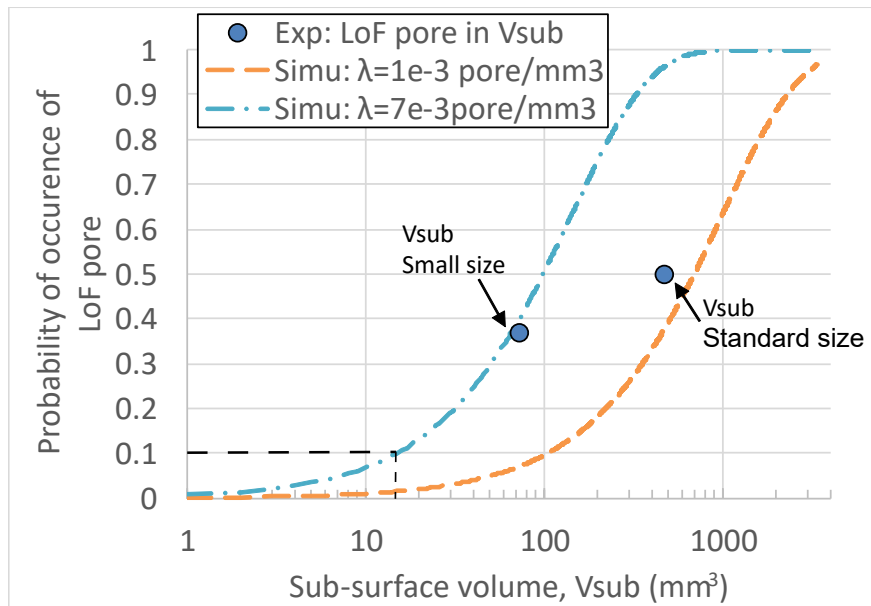

Figure 20: Correlation between the sub-surface volume and the probability of occurrence of surface LoF pores

432
433 ity of LoF pores increases rapidly. For this range of LoF pore density, the maximum size of the
434 sub-surface volume in the loaded zone (i.e. the critical volumes) must not be greater than approxi-
435 mately 15 mm³ so that the probability of occurrence of surface LoF pore in this zone is lower than
436 10%.

437 In short, the proposed probabilistic approach gives an effective methodology to estimate the
438 probability of occurrence of LoF pores in a given volume. However, it must be kept in mind that

439 the spatial distribution and the volumetric pore density of the LoF pores are two important inputs
440 that must be known in this approach.

441 **5. Conclusion**

442 This paper deals with the scatter and the statistical scale/size effect of the fatigue behaviour of a
443 SLM Ti-6Al-4V alloy. An experimental campaign was conducted on four specimen configurations
444 with two specimen volumes (standard size and small size) and two surface conditions (as-built and
445 machined). Numerous analyses, including an S-N curve analysis taking into account the defect
446 size and the Kitagawa-Takahashi diagram, have been done to understand the origin of the size
447 effect and the fatigue scatter that were observed. The principal results are as follow:

448 For the machined specimens:

- 449 • The presence of several fatigue crack initiation mechanisms with very different fatigue be-
450 haviours is the origin of the high scatter in the S-N data. The fatigue behaviour depends not
451 only on the defect type (LoF pores or gas pores) but also on the spatial position of the defect
452 (at the surface or in the bulk). The effect of the spatial position is particularly pronounced
453 for the LoF pores. The classical Murakami approach cannot adequately predict this effect.
- 454 • The size effect observed for the machined specimens can also be explained by the variety
455 of the crack initiation mechanisms. When analysing the mechanisms separately, only a very
456 slight or no effect was observed because the sizes of LoF pores or the gas pores are the same
457 for both investigated specimen volumes. The size effect is linked principally to the change
458 of mechanism. In other words, the probability of occurrence of LoF pores and/or Gas pores
459 in a given volume changes with a change in loaded volume.

460 For the as-built specimens:

- 461 • Compared to the machined specimens, the scatter in the S-N data and the size effect for the
462 as-built specimens are greatly reduced. Despite the presence of two different crack initiation
463 mechanisms, the similar fatigue behaviour for these mechanisms results in less scatter and
464 and a lower size effect.

- 465 • The fatigue behaviour related to the surface LoF pores was compared between the machined
466 surface and the as-built surface conditions. It was shown that for a similar LoF pore size,
467 the fatigue strength of the as-built specimens is 30% lower than that of the machined speci-
468 mens. This implies that other factors, such as the sub-surface microstructure or the surface
469 roughness may play a non-negligible role on the fatigue behaviour.

470 In the final part of this article, the size effect was modelled by considering the probability of
471 occurrence of LoF pores in a given volume. The proposed model leads to useful tools that can be
472 used in the qualification of the AM fabrication process or in the fatigue design of components.

473 **Acknowledgement**

474 This study is part of the FASICOM project, managed by IRT Jules Verne (French Institute of
475 Research and Technology in Advanced Manufacturing Technologies for Composite, Metallic and
476 Hybrid Structures). The authors wish to associate the following industrial partners with this work:
477 ADDUP, AIRBUS, ArianeGroup and General Electric.

478 **References**

- 479 [1] E. Wycisk, A. Solbach, S. Siddique, D. Herzog, F. Walther, C. Emmelmann, Effects of defects in laser additive
480 manufactured ti-6al-4v on fatigue properties, *Physics Procedia* 56 (2014) 371–378. doi:10.1016/j.phpro.
481 2014.08.120.
- 482 [2] J. Günther, D. Krewerth, T. Lippmann, S. Leuders, T. Tröster, A. Weidner, H. Biermann, T. Niendorf, Fatigue
483 life of additively manufactured ti-6al-4v in the very high cycle fatigue regime, *International Journal of Fatigue*
484 94 (2017) 236–245. doi:10.1016/j.ijfatigue.2016.05.018.
- 485 [3] V. Chastand, P. Quaegebeur, W. Maia, E. Charkaluk, Comparative study of fatigue properties of ti-6al-4v
486 specimens built by electron beam melting (ebm) and selective laser melting (slm), *Materials Characteri-
487 zation* 143 (2018) 76 – 81, *metal Additive Manufacturing: Microstructures and Properties*. doi:https:
488 //doi.org/10.1016/j.matchar.2018.03.028.
489 URL <http://www.sciencedirect.com/science/article/pii/S1044580317331741>
- 490 [4] D. Greitemeier, F. Palm, F. Syassen, T. Melz, Fatigue performance of additive manufactured TiAl6v4 us-
491 ing electron and laser beam melting, *International Journal of Fatigue* 94 (2017) 211–217. doi:10.1016/j.
492 ijfatigue.2016.05.001.

- 493 [5] Y. Hu, S. Wu, P. Withers, J. Zhang, H. Bao, Y. Fu, G. Kang, The effect of manufacturing defects on the fatigue
494 life of selective laser melted ti-6al-4v structures, *Materials & Design* 192 (2020) 108708. doi:10.1016/j.
495 matdes.2020.108708.
- 496 [6] R. Biswal, X. Zhang, A. K. Syed, M. Awd, J. Ding, F. Walther, S. Williams, Criticality of porosity defects on
497 the fatigue performance of wire + arc additive manufactured titanium alloy, *International Journal of Fatigue* 122
498 (2019) 208–217. doi:10.1016/j.ijfatigue.2019.01.017.
- 499 [7] A. Yadollahi, M. Mahtabi, A. Khalili, H. Doude, J. Newman, Fatigue life prediction of additively manufactured
500 material: Effects of surface roughness, defect size, and shape, *Fatigue & Fracture of Engineering Materials &
501 Structures* 41 (7) (2018) 1602–1614. doi:10.1111/ffe.12799.
- 502 [8] B. Vayssette, N. Saintier, C. Brugger, M. E. May, E. Pessard, Numerical modelling of surface roughness effect
503 on the fatigue behavior of ti-6al-4v obtained by additive manufacturing, *International Journal of Fatigue* 123
504 (2019) 180 – 195. doi:https://doi.org/10.1016/j.ijfatigue.2019.02.014.
505 URL <http://www.sciencedirect.com/science/article/pii/S0142112319300416>
- 506 [9] K. S. Chan, M. Koike, R. L. Mason, T. Okabe, Fatigue life of titanium alloys fabricated by additive layer
507 manufacturing techniques for dental implants, *Metallurgical and Materials Transactions A* 44 (2) (2012) 1010–
508 1022. doi:10.1007/s11661-012-1470-4.
- 509 [10] M. H. Nasab, S. Romano, D. Gastaldi, S. Beretta, M. Vedani, Combined effect of surface anomalies and volu-
510 metric defects on fatigue assessment of als17mg fabricated via laser powder bed fusion, *Additive Manufacturing*
511 (2019) 100918doi:https://doi.org/10.1016/j.addma.2019.100918.
512 URL <http://www.sciencedirect.com/science/article/pii/S2214860419310991>
- 513 [11] M. Nakatani, H. Masuo, Y. Tanaka, Y. Murakami, Effect of surface roughness on fatigue strength of ti-6al-
514 4v alloy manufactured by additive manufacturing, *Procedia Structural Integrity* 19 (2019) 294–301. doi:10.
515 1016/j.prostr.2019.12.032.
- 516 [12] H. Masuo, Y. Tanaka, S. Morokoshi, H. Yagura, T. Uchida, Y. Yamamoto, Y. Murakami, Influence of defects,
517 surface roughness and HIP on the fatigue strength of ti-6al-4v manufactured by additive manufacturing, *Inter-
518 national Journal of Fatigue* 117 (2018) 163–179. doi:10.1016/j.ijfatigue.2018.07.020.
- 519 [13] J. Pegues, M. Roach, R. S. Williamson, N. Shamsaei, Surface roughness effects on the fatigue strength of
520 additively manufactured ti-6al-4v, *International Journal of Fatigue* 116 (2018) 543 – 552. doi:https://doi.
521 org/10.1016/j.ijfatigue.2018.07.013.
522 URL <http://www.sciencedirect.com/science/article/pii/S0142112318302986>
- 523 [14] A. Fatemi, R. Molaei, J. Simsiriwong, N. Sanaei, J. Pegues, B. Torries, N. Phan, N. Shamsaei, Fatigue behaviour
524 of additive manufactured materials: An overview of some recent experimental studies on ti-6al-4v considering
525 various processing and loading direction effects, *Fatigue & Fracture of Engineering Materials & Structures* 42 (5)
526 (2019) 991–1009. arXiv:https://onlinelibrary.wiley.com/doi/pdf/10.1111/ffe.13000, doi:10.

527 1111/ffe.13000.
528 URL <https://onlinelibrary.wiley.com/doi/abs/10.1111/ffe.13000>

529 [15] V.-D. Le, E. Pessard, F. Morel, F. Edy, Interpretation of the fatigue anisotropy of additively manufactured ta6v
530 alloys via a fracture mechanics approach, *Engineering Fracture Mechanics* 214 (2019) 410 – 426. doi:<https://doi.org/10.1016/j.engfracmech.2019.03.048>.
531 [//doi.org/10.1016/j.engfracmech.2019.03.048](https://doi.org/10.1016/j.engfracmech.2019.03.048).
532 URL <http://www.sciencedirect.com/science/article/pii/S0013794418311664>

533 [16] A. International, ASTM F3001-14, Standard Specification for Additive Manufacturing Titanium-6 Aluminum-4
534 Vanadium ELI (Extra Low Interstitial) with Powder Bed Fusion Cited By 5.

535 [17] L. Thijs, F. Verhaeghe, T. Craeghs, J. V. Humbeeck, J.-P. Kruth, A study of the microstructural evolution during
536 selective laser melting of ti-6al-4v, *Acta Materialia* 58 (9) (2010) 3303–3312. doi:10.1016/j.actamat.
537 2010.02.004.

538 [18] G. Kasperovich, J. Hausmann, Improvement of fatigue resistance and ductility of TiAl6v4 processed by se-
539 lective laser melting, *Journal of Materials Processing Technology* 220 (2015) 202–214. doi:10.1016/j.
540 jmatprotec.2015.01.025.

541 [19] R. D. Pollak, A. N. Palazotto, A comparison of maximum likelihood models for fatigue strength characterization
542 in materials exhibiting a fatigue limit, *Probabilistic Engineering Mechanics* 24 (2) (2009) 236 – 241. doi:
543 <https://doi.org/10.1016/j.probenmech.2008.06.006>.
544 URL <http://www.sciencedirect.com/science/article/pii/S026689200800057X>

545 [20] M. Donachie, *Titanium: a technical guide*, ASM International, 2000.
546 URL <https://books.google.fr/books?id=IJFUAAAAMAAJ>

547 [21] H. Gong, K. Rafi, T. Starr, B. Stucker, Effect of defects on fatigue tests of as-built ti-6al-4v parts fabricated
548 by selective laser melting, in: *23rd Annual International Solid Freeform Fabrication Symposium - An Additive
549 Manufacturing Conference, SFF 2012, 2012*.

550 [22] H. K. Rafi, T. L. Starr, B. E. Stucker, A comparison of the tensile, fatigue, and fracture behavior of ti-6al-4v
551 and 15-5 PH stainless steel parts made by selective laser melting, *The International Journal of Advanced Manu-
552 facturing Technology* 69 (5-8) (2013) 1299–1309. doi:10.1007/s00170-013-5106-7.

553 [23] K. Walker, Q. Liu, M. Brandt, Evaluation of fatigue crack propagation behaviour in ti-6al-4v manufactured by
554 selective laser melting, *International Journal of Fatigue* 104 (2017) 302 – 308. doi:[https://doi.org/10.
555 1016/j.ijfatigue.2017.07.014](https://doi.org/10.1016/j.ijfatigue.2017.07.014).
556 URL <http://www.sciencedirect.com/science/article/pii/S0142112317303043>

557 [24] B. Gerin, E. Pessard, F. Morel, C. Verdu, A non-local approach to model the combined effects of forging defects
558 and shot-peening on the fatigue strength of a pearlitic steel, *Theoretical and Applied Fracture Mechanics* 93
559 (2018) 19 – 32. doi:<https://doi.org/10.1016/j.tafmec.2017.06.012>.
560 URL <http://www.sciencedirect.com/science/article/pii/S0167844217301209>

- 561 [25] S. Pomberger, M. Stoschka, R. Aigner, M. Leitner, R. Ehart, Areal fatigue strength assessment of cast alu-
562 minium surface layers, *International Journal of Fatigue* 133 (2020) 105423. doi:10.1016/j.ijfatigue.
563 2019.105423.
- 564 [26] E. Gumbel, *Statistical theory of extreme values and some practical applications: a series of lectures*, Applied
565 mathematics series, U. S. Govt. Print. Office, 1954.
566 URL <http://books.google.fr/books?id=SNpJAAAAMAAJ>
- 567 [27] Y. Murakami, *Effects of small defects and nonmetallic inclusions*, Elsevier, 2002.
- 568 [28] D. E. Khoukhi, F. Morel, N. Saintier, D. Bellett, P. Osmond, V.-D. Le, J. Adrien, Experimental investigation of
569 the size effect in high cycle fatigue: Role of the defect population in cast aluminium alloys, *International Journal*
570 *of Fatigue* 129 (2019) 105222. doi:<https://doi.org/10.1016/j.ijfatigue.2019.105222>.
571 URL <http://www.sciencedirect.com/science/article/pii/S0142112319303263>
- 572 [29] R. Molaei, A. Fatemi, N. Sanaei, J. Pegues, N. Shamsaei, S. Shao, P. Li, D. Warner, N. Phan, Fatigue of
573 additive manufactured ti-6al-4v, part II: The relationship between microstructure, material cyclic properties, and
574 component performance, *International Journal of Fatigue* 132 (2020) 105363. doi:10.1016/j.ijfatigue.
575 2019.105363.
- 576 [30] M.J.Caton, J.W.Jones, H.Mayer, S. Stanzl-Tschegg, J.E.Allison, Demonstration of an endurance limit in cast
577 319 aluminum, *Metallurgical and Materials Transactions A* 34 (11) (2003) 33–41.
- 578 [31] N. Hrabe, T. Gnäupel-Herold, T. Quinn, Fatigue properties of a titanium alloy (ti6al4v) fabricated via electron
579 beam melting (ebm): Effects of internal defects and residual stress, *International Journal of Fatigue* 94 (2017)
580 202 – 210, *fatigue and Fracture Behavior of Additive Manufactured Parts*. doi:[https://doi.org/10.1016/](https://doi.org/10.1016/j.ijfatigue.2016.04.022)
581 [j.ijfatigue.2016.04.022](https://doi.org/10.1016/j.ijfatigue.2016.04.022).
582 URL <http://www.sciencedirect.com/science/article/pii/S0142112316300767>
- 583 [32] X. Shui, K. Yamanaka, M. Mori, Y. Nagata, K. Kurita, A. Chiba, Effects of post-processing on cyclic fatigue
584 response of a titanium alloy additively manufactured by electron beam melting, *Materials Science and Engineer-*
585 *ing: A* 680 (2017) 239–248. doi:10.1016/j.msea.2016.10.059.
- 586 [33] S. Leuders, T. Lieneke, S. Lammers, T. Tröster, T. Niendorf, On the fatigue properties of metals manufactured
587 by selective laser melting – the role of ductility, *Journal of Materials Research* 29 (17) (2014) 1911–1919.
588 doi:10.1557/jmr.2014.157.
- 589 [34] Y. Murakami, S. Beretta, Small defects and inhomogeneities in fatigue strength: Experiments, models and
590 statistical implications, *Extremes* 2 (2) (1999) 123–147. doi:10.1023/A:1009976418553.
591 URL <https://doi.org/10.1023/A:1009976418553>
- 592 [35] O. Andreau, E. Pessard, I. Koutiri, J.-D. Penot, C. Dupuy, N. Saintier, P. Peyre, A competition between the
593 contour and hatching zones on the high cycle fatigue behaviour of a 316l stainless steel: Analyzed using x-ray
594 computed tomography, *Materials Science and Engineering: A* 757 (2019) 146 – 159. doi:<https://doi.org/>

- 595 10.1016/j.msea.2019.04.101.
596 URL <http://www.sciencedirect.com/science/article/pii/S0921509319305763>
- 597 [36] A. Junet, A. Messenger, X. Boulnat, A. Weck, E. Boller, L. Helfen, J.-Y. Buffiere, Fabrication of artificial defects
598 to study internal fatigue crack propagation in metals, *Scripta Materialia* 171 (2019) 87–91. doi:10.1016/j.
599 scriptamat.2019.05.018.
- 600 [37] I. Serrano-Munoz, J.-Y. Buffiere, C. Verdu, Y. Gaillard, P. Mu, Y. Nadot, Influence of surface and internal
601 casting defects on the fatigue behaviour of a357-t6 cast aluminium alloy, *International Journal of Fatigue* 82,
602 Part 3 (2016) 361 – 370. doi:<http://dx.doi.org/10.1016/j.ijfatigue.2015.07.032>.
603 URL <http://www.sciencedirect.com/science/article/pii/S0142112315002509>
- 604 [38] K. S. R. Chandran, Duality of fatigue failures of materials caused by poisson defect statistics of competing
605 failure modes, *Nature Materials* 4 (4) (2005) 303–308. doi:10.1038/nmat1351.
- 606 [39] P. Osmond, V.-D. Le, F. Morel, D. Bellett, N. Saintier, Effect of porosity on the fatigue strength of cast
607 aluminium alloys: from the specimen to the structure, *Procedia Engineering* 213 (2018) 630–643. doi:
608 10.1016/j.proeng.2018.02.059.
- 609 [40] V.-D. Le, N. Saintier, F. Morel, D. Bellett, P. Osmond, Investigation of the effect of porosity on the high cycle
610 fatigue behaviour of cast al-si alloy by x-ray micro-tomography, *International Journal of Fatigue* 106 (2018)
611 24–37. doi:10.1016/j.ijfatigue.2017.09.012.