



Science Arts & Métiers (SAM)

is an open access repository that collects the work of Arts et Métiers Institute of Technology researchers and makes it freely available over the web where possible.

This is an author-deposited version published in: <https://sam.ensam.eu>
Handle ID: <http://hdl.handle.net/10985/8359>

To cite this version :

Olivier COMA, Christian MASCLE, Philippe VERON - Geometric and form feature recognition tools applied to a design for assembly methodology - Computer-Aided Design - Vol. 35, p.1193-1210 - 2003

Any correspondence concerning this service should be sent to the repository

Administrator : scienceouverte@ensam.eu



Geometric and form feature recognition tools applied to a design for assembly methodology

O. Coma^a, C. Mascle^{a,*}, P. Véron^b

^a*Department de Mecanique, École Polytechnique de Montréal, Section Fabrication, C.P. 6079 Succ. Centre-Ville, Montréal, Que., Canada H3C 3A7*

^b*ENSAM, 2 Cours des Arts et Métiers, 13617 Aix-en-Provence, France*

Abstract

The paper presents geometric tools for an automated Design for Assembly (DFA) assessment system. For each component in an assembly a two step features search is performed: firstly (using the minimal bounding box) mass, dimensions and symmetries are identified allowing the part to be classified, according to DFA convention, as either rotational or prismatic; secondly form features are extracted allowing an effective method of mechanised orientation to be determined. Together these algorithms support the fuzzy decision support system, of an assembly-orientated CAD system known as FuzzyDFA.

Keywords: Design for assembly; Bounding box; Symmetry; Feature recognition; Orientation analysis; Fuzzy logic

1. Introduction

Design for Assembly (DFA) is an important manufacturing tool that can substantially reduce the costs attributable to assembly. Besides cost reduction, DFA generates additional benefits such as higher quality, increased reliability, and shorter manufacturing time. A major effort was made to develop DFA methodologies during the eighties. Since their emergence, two different approaches have been investigated. The first method focuses on the evaluation of each elementary part of a product whereas the second considers the product as a whole [1].

The main reference used in this paper is the well-known Boothroyd–Dewhurst methodology [2] (B–D’s DFA), which can be applied to either manual or automated assemblies. A number of reference tables are used to evaluate each part in terms of ease of handling, ease of insertion as well as its relevance to the assembly. The findings are then compared to proprietary data. This evaluation process makes use of geometric and technological data for each part. From the geometric standpoint, parts are studied individually, whereas on the technological side, relationships between them are taken into consideration.

This work when combined with the author’s DFA methodology (in which fuzzy logic is introduced [3,4]) allows feature-based part codes to be used as input for DFA evaluation [5]. The technique described in this paper was developed to minimize designer inputs by performing a computerized geometric information search and using artificial intelligence to automate the DFA evaluation process through fuzzy logic. Fig. 1 provides the structure of *FuzzyDFA*; a fuzzy decision support system software, and demonstrates how a product and its parts are evaluated through the inference process.

The DFA knowledge base is composed of 29 fuzzy models which represent the Boothroyd–Dewhurst methodology in its entirety. The part evaluation process uses technological and geometric data, as shown in Fig. 2. Geometric outputs become inputs for the inference process, and hence for fuzzy models. Therefore, specifying geometric requirements for DFA and implementing associated algorithms reduce manual inputs to technological information.

In this paper geometric requirements for manual and automated assembly operations are identified and an approach is proposed to automatically extract the required information from component geometric models. Then, an approach is described to compute a bounding box and

* Corresponding author.

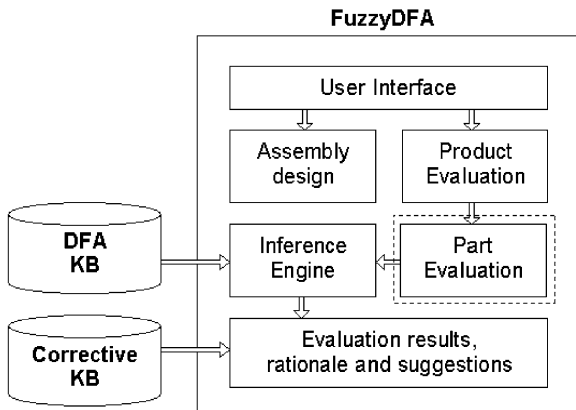

Fig. 1. Organization diagram of the *FuzzyDFA* application (KB: knowledge base).

symmetry characteristics of each part according to the DFA methodology. These geometric properties are qualified as basic DFA requirements since they are always used by the evaluation process, whether or not the assembly operations are automated, and operate on the original parametric B-Rep model of parts.

The evaluation of automated assembly operations requires further geometric information. The shape of each component must be analyzed in order to find how to automatically orient that part by mechanical selections. This key step in the Boothroyd–Dewhurst methodology requires 2D and 3D feature recognition processes as well as an algorithm to define the best orientation solution, i.e. combination of form features, for a part in order to insert it in the partial product in the most efficient way. For this purpose, the notion of feature orientation capability is introduced in the next sections. A faceted B-Rep model of parts is used in this paper for the 2D-form features extraction. Application of this model reduces the algorithmic complexity. Various algorithms are presented for the 3D-form features extraction. They use the original parametric B-Rep model of parts.

1.1. Overview of geometric requirements for DFA

Basic DFA requirements are always used for manual assembly analyses. However, feature recognition processes

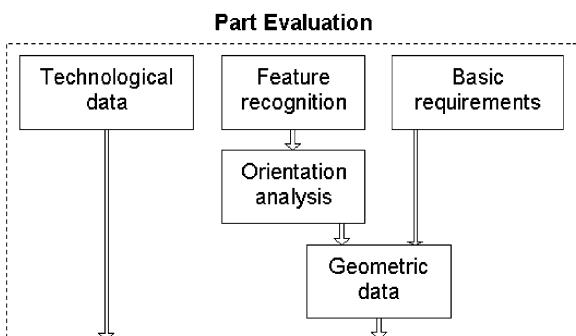

Fig. 2. Data required for DFA evaluation.

Table 1
Part geometric characteristics required

Rotational part	Other part (non-rotational)	
Dimensions : L, D	Dimensions : A, B, C	Basic requirements
	Axis symmetries X, Y et Z	
Weight		Feature recognition
α, β symmetries		
Steps, Grooves, Cavities,		
Steps, grooves and cavities with small dimensions, area $< \frac{\min^2\{L,d\}}{100}$ or $< \frac{\min^2\{A,B,C\}}{100}$		

are only needed for automated assembly operations. Table 1 lists geometric requirements for the DFA methodology used.

Dimensions L, D for rotational parts and A, B, C for non-rotational ones, with the symmetry axes X, Y , and Z are computed from a part's minimal bounding box (see Section 4).

$\beta(\alpha)$ symmetry is the angle through which a part must be rotated around its insertion axis (an axis perpendicular to its insertion axis) in order to repeat its orientation. The insertion axis is defined manually in the *FuzzyDFA* system.

Boothroyd–Dewhurst [2] dedicates specific Tables for defining the orientation of parts in automated assembly operations. Parts are oriented and distributed by bowl feeders. These bowls perform mechanical selections that define, step-by-step, the orientation of a part. During each step, non-conforming parts are discarded as shown in Fig. 3.

For a non-rotational part, 2D features in one or more planar projections, i.e. projections along X, Y, Z axes of the bounding box respectively named $ProjX, ProjY, ProjZ$, could be used to partially or completely define the part orientation (Fig. 3). 2D steps and 2D groove features are of interest when a part is progressing in a straight-line movement. But 2D features alone might not be adequate to orient a part. For example, if the component shape is a cube with a blind hole on one of its faces, no 2D feature could be detected in a 2D projection. The only feature that can be used to orient the part is its blind hole, i.e. a 3D feature.

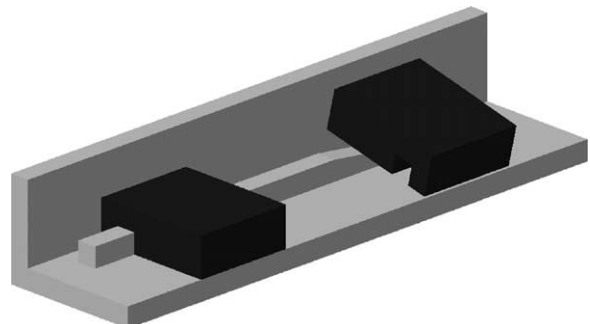

Fig. 3. Orientation of parts using mechanical selections in a bowl feeder.

For a rotational part the Boothroyd–Dewhurst’s Table refers to α symmetry and β symmetric (2D and 3D) features to orient the part relative to its end faces. The former Table exploits β symmetry and β asymmetric features to orient the part around its Z axis. In the B–D’s DFA technique, operation time for automatic manipulation for a prismatic part or a cylindrical part is evaluated in terms of ease of handling using three Tables. For the part shown in Fig. 11, B–D’s DFA code is 21400. From the first table (corresponding to the fourth table in B–D’s DFA), 2 is deduced as the first number in this code because the part is rotational and its shape is a long cylinder because $L/D > 1.5$ (L and D are, respectively, the length and the diameter of the component’s cylindrical bounding box). From the second table (corresponding to the fifth table in B–D’s DFA), 1 is deduced as the second number because the part is α asymmetric and contains a β symmetric step feature. It could be supported by a large flange and the center of gravity is below the support face. Continuing from the second Table, 4 is deduced as the third number because the part is β asymmetric and contains a β asymmetric chamfer. From the third table (corresponding to the seventh Table in B–D’s DFA), 00 are deduced as fourth and fifth code numbers because the part is a normal size, with a non-abrasive surface, is not flexible, non sticky, non tangling, etc.

Lastly, Boothroyd–Dewhurst methodology requires feature type, axis and size information. Type and axis allow deduction of feature orientation efficiency, while the size is used to place features that have the same orientation capacity in order by decreasing size. This technique allows the selection of the most appropriate feature among partner features (same type, same axis) to design the bowl feeder. Feature decomposition is useless for DFA since partitioning two intersecting features does not help solve the orientation problem. The aim of the orientation algorithm is to select the most appropriate features that maximize the orientation efficiency of a part. Therefore, partitioning features may only influence the number of features required to orient the part. The next section introduces previous works related to the topic of this paper.

2. Related works

Li and Hwang [6] developed a semi-automated system that closely follows Boothroyd–Dewhurst methodology. Their approach considers multiple assembly sequences and times all feasible ones. However, they perform limited feature recognition for assembly and many of the geometric and non-geometric required information must be input manually.

In Ong and Lye [7], Rosario [8], a wire-frame representation scheme of the CAD part model is used in the development and implementation of computerized algorithms to calculate overall dimensions and rotational symmetries. Although algorithms are based on topological

relationships and a palindrome search, the wire-frame geometric model restricts them to very simple parts due to the lack of topological information inherent to this geometric representation.

Sturges and Kilani [9] built an analysis system that enables the extraction of several features (dimensions, shape, and symmetry of a part) relevant to assembly processes. Although a feature recognition process is described, their work does not refer to a systematic technique for solving the orientation problem.

None of these works systematically meets all the DFA geometric requirements, and hence, they lack geometric reasoning capabilities. This shortcoming is addressed using the approach demonstrated in this paper. The traditional role of automatic feature recognition in CAD is to identify the machinable features on a 3D CAD model of a mechanical component. There are a large number of research papers on Feature Recognition Algorithms for machining and this review contains only a sample. For a more complete review of automatic feature recognition methods, the reader is referred to Han et al. [10] or Marefat and Ji [11].

A review of the literature reveals that features are defined in different ways by various authors. Each author uses his own definition which, in fact, translates his specific point of view on the product model according to its application. In developing the SCAP system however, the widest definition possible was adopted (Jabbour et al. [12]).

Definition 1. *An assembly feature (AF) is defined as any topological, geometrical, technological or functional information assigned to a face, a part or a sub-assembly, whose presence is inherent to the assembly process.*

In this work for *FuzzyDFA*, Boothroyd–Dewhurst’s DFA [2] definition was adopted. Boothroyd–Dewhurst [2] introduced the concept of the degenerated envelope in order to find a DFA minimal bounding box for a part. Essentially, the degenerated envelope is the cylinder, or rectangular prism obtained when small geometric details of the part, visible on planar projections, are neglected. Although this approach provides good theoretical results, it uses the relative notion of feature size, implying that criteria to decompose features must be found. This bounding box search process has proven to be difficult to automate.

Finally, literature abounds on feature recognition. ‘Feature technology’ [13] describes advances in feature recognition as well as the contexts in which features are of interest. A form feature can be defined as a partial form or a part characteristic that is considered as a unit and that has a semantic meaning in design, process planning, manufacturing, cost estimation or other engineering disciplines [13]. Feature recognition is a post-processing technique, meaning that some procedures need to be applied to the geometry of a part in order to recognize its features. Approaches can be classified into five main groups [14,15] as follows:

Edge-based recognition. This is the oldest method, which interrogates each edge in a B-Rep model to ascertain whether the edge is concave, convex or smooth (extension of filleted edges). Specific rules are then applied to faces that share concave edges in order to select candidate faces to form a valid feature [16],

Volume and convex decomposition. This technique uses the resulting volumes of the subtraction of the convex hull of the part by the part itself. Thereafter, an iterative process attempts to generate a destructive solid geometry (DSG) tree for each of these volumes, using the alternating sum of volumes technique [17,18],

Graph-based recognition. Graph-based algorithms organize B-Rep information of a component into graph structures. These graphs can have either faces, edges or vertices as nodes and any of the other two-entities as arcs. During process recognition, these graphs are split into sub-graphs using well-developed graph manipulation algorithms, until each sub-graph matches a predefined feature graph [19],

Neural network-based recognition. Artificial neural nets have been studied for many years in hopes of achieving human-like performance. Since inputs and weights of each node are allowed to change over time, the neural net can be said to adapt and learn. Through learning, it can collect characteristics of a geometric/topological pattern and recognize existing useful features. The main advantage of neural nets over graph-based approaches is that they can tolerate a slight input error during learning or solving problems [20]. Therefore, the net can make a reasonable guess when problems are outside the range of its learning experience, and this property can be exploited in recognizing componential or interrupted features. But the learning process needs a large number of component samples and hence limits current implementations of neural-net techniques,

Rule-based recognition. Features are defined by sets of rules. The recognition process consists in matching the geometric properties and the topological data structure of the component with established rules [21]. The general form of a rule is: *If* (A_1, \dots, A_n) *Then* F , where (A_1, \dots, A_n) is the set of conditions that define the feature F . Topology of the component is often the root of rule-based approaches. This type of technique requires a large number of rules in order to explore a wide domain of features, and is inadequate for separating intersecting features, i.e. complex feature decomposition is difficult to perform. But the technique is simple to implement and meets DFA requirements in terms of features.

3. Part and product data structures

Before developing how DFA requirements are solved, data structures used in *FuzzyDFA*, especially feature classes, are described in this section. As shown in Fig. 4, the part class

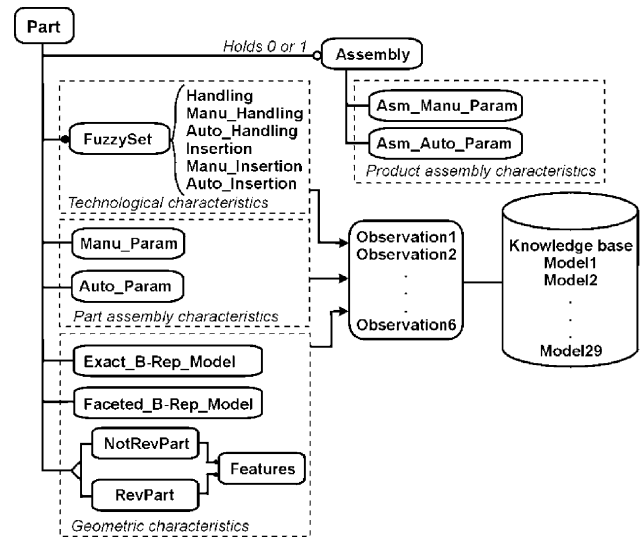

Fig. 4. Part and product data structures used in *FuzzyDFA* application.

aggregates technological characteristics represented by fuzzy sets (i.e. the material), component assembly characteristics (i.e. mating with other parts), and geometric characteristics (i.e. symmetries, form features). Appending product assembly characteristics such as the rate per hour of an assembly operator, allows the part class to be extended to support a product. Form features are the most complex geometric characteristics used in *FuzzyDFA*. Two classes were created to handle 2D and 3D features. The minimum information contained in each of them is as follows:

- The faceted B-Rep model of the feature’s underlying geometry,
- The identified feature type,
- The measured feature size,
- The feature axis.

Fig. 4 highlights the two CAD representations used in *FuzzyDFA*. CAD systems are currently used to describe a part by a parametric based B-Rep solid model in order to enable efficient product data management. In *FuzzyDFA*, geometric and topological entities of such a model are described using the STEP AP203 standard. Downstream engineering applications however, such as finite element analysis, may use other representations of the part. A faceted B-Rep model generated by a tessellation process on the parametric based original model is used to solve the DFA requirement problem. The tessellation is based on a Delaunay method and built according to a user-specified precision.

4. Basic geometric requirements

Although basic geometric requirements seem easy to find, dimensions and symmetries depend on the 3D

coordinate system attached to the part. When using a 3D modeler, designers usually create parts in a global 3D coordinate system which is predefined for a given product or sub-product by the product architect. But there is no a priori reason to ensure that this coordinate system is convenient to measure basic DFA requirements. Consequently, a minimal bounding box for each part must be first computed to enable DFA evaluations.

4.1. Minimal bounding box for DFA

For a given part, the approach is based on a topological exploration of its parametric based B-Rep model. The proposed algorithm explores this model to classify the part as rotational or not. To this end, faces of the B-Rep model are grouped into different sets to identify the main shape characteristics of the part. The proposed approach is illustrated with the part in Fig. 5:

The first step consists in classifying faces of the part model into three sets: F_{PLN} gathers planar faces, F_{REV} for

revolution faces and F_{OTH} for other geometric faces (free-form faces). The F_{PLN} set is then sub-structured by grouping faces with the same normal. In the same way, the F_{REV} set is sub-structured by grouping faces with the same revolution axis or the same centre point for spherical faces. Inside the F_{PLN} set, some faces must be differentiated. For example, although both end faces of a cylinder are planar, they contribute to make the part rotational. Consequently, for each planar face f , a test evaluates whether it must be added to the F_{REV} face set or not. This test explores edges of each planar face and gathers them in two sets: circular and other. Then, the total length L_1 of edges in other sets is compared to the longest edge L_2 in a sub-set of the circular set. Sub-sets of the circular set are obtained as before by grouping circular edges which have the same centre point. If $L_1 > L_2$ then f is added to F_{PLN} ; else to F_{REV} . For the part shown in Fig. 5, the results are:

$$F_{PLN} = \{\{f_1, f_4, f_9\}, \{f_3, f_5, f_7\}, \{f_2, f_6\}, \{f_8\}\},$$

$$F_{REV} = \{\{f_{11}, f_{12}\}, \{f_{13}, f_{14}\}, \{f_{10}\}\}$$

and

$$F_{OTH} = \{ \}.$$

The second step performs new grouping operations (GF_{PLN}, GF_{REV}) on the F_{PLN} and F_{REV} sets to highlight the main shape characteristics of the part and to conclude on its classification as rotational or not. Face sub-sets of F_{PLN} are grouped if they have collinear or perpendicular normals. In the same way, a planar face f_{pl} of the F_{REV} set is grouped with sub-set (F_{REV_i}) of F_{REV} if the centre point of the longest circular edge of f_{pl} is located on the revolution axis of F_{REV_i} .

For the part shown in Fig. 5, the results are:

$$GF_{PLN} = \{\{f_1, f_2, f_3, f_4, f_5, f_6, f_7, f_9\}, \{f_8\}\},$$

$$GF_{REV} = \{\{f_{10}, f_{11}, f_{12}, f_{13}, f_{14}\}\}$$

and

$$F_{OTH} = \{ \}.$$

The areas ($Area_{GF_{PLN}}$ and $Area_{F_{OTH}}$) of GF_{PLN} and F_{OTH} sets are computed as the sum of all the face areas of the set, and the area ($Area_{GF_{REV}}$) of the GF_{REV} set is also computed as follows:

$$Area_{GF_{REV}} = \sup_{i=1}^n (area_{GF_{REV_i}}) \quad (1)$$

where: $area_{GF_{REV_i}}$ is the area of the sub-set i of the GF_{REV} set.

Finally, the part is classified as rotational if $Area_{GF_{REV}} > (Area_{GF_{PLN}} + Area_{F_{OTH}})$. Rotational parts described using free-form surface patches (Bézier, B-Spline, NURBS) are not identified using this approach but such parts are not frequently encountered in the design of mechanical products. In accordance with this approach, the part described in Fig. 5 will be classified as non-rotational.

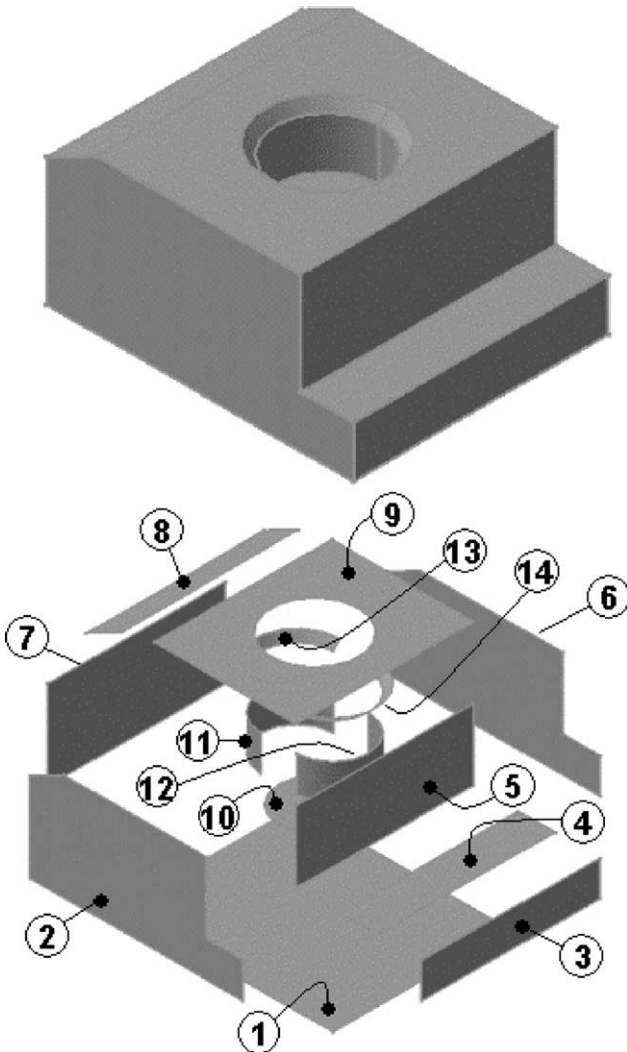

Fig. 5. Face-based topological decomposition of the part B-Rep model.

The last step of the approach assigns a 3D coordinate system to the part which is the support for its bounding box. From a mechanical engineering point of view and as per the DFA methodology requirements, a 3D coordinate system is defined from the three main inertia axes of the part and its origin is located at the inertia centre point. The bounding box of minimum volume that encloses the part is thus built from this 3D coordinate system using classical algorithms [22] according to the following rules: for rotational parts, the Z axis is chosen along the rotational axis previously identified and, for non-rotational parts, the X axis is chosen corresponding to the largest dimension of the bounding box and the Z axis to the smallest one.

4.2. Symmetries

In DFA methodology, α and β symmetry properties defined in Section 1 are required to estimate the orientation and insertion part efficiency in the assembled product and to correctly orient the parts for automated assembly operations. Partial symmetry detection processes [23] can be useful for roughly orienting a part but are not convenient to automated insertion operations since the part must be well oriented. The method used here is based on existing works [24], and the complete rotational α and β symmetry properties are detected. A part is considered to be α or β symmetric if an angle Φ exists ($\Phi = 360^\circ/n$ with $n \geq 2$) around an appropriate axis Δ such that the intersection volume between the part before and after rotation of Φ around Δ is null (or close to zero). For the DFA orientation approach described in Section 5, α and β symmetry properties are sought for each part around the three axes of its associated coordinate system previously defined.

5. Feature recognition processes

5.1. 2D feature recognition

When a part is conveyed into a bowl feeder, 2D projections of its geometric model enable the definition of possible solutions for its orientation. Relevant features are those relative to the 2D bounding box of these projections. This section details the 2D-feature recognition process proposed to extract these relevant features for DFA purposes. First, the outer wire of the part projection is computed using standard classical routines (Fig. 6). To increase the algorithm efficiency and reduce computation time, the part faceted model is simplified using a vertex based removal technique previously developed [25]. The decimation is processed according to a user specified tolerance ϵ and redundant vertices and edges of length inferior to ϵ are removed. Fig. 6 shows the part outer wire computation for a Z axis projection.

A planar face f is then created on the outer wire defined and subtracted from f_bnd_{2D} , the rectangular face that bounds the outer wire face. The set of faces N thus produced ($N = f_bnd_{2D} - f$) is the basis for the feature detection process. Four kinds of 2D features are defined to fulfil DFA requirements: Feat2d_Groove, Feat2d_Step, Feat2d_Other and Feat2d_Nothing. For each face f_{Ni} belonging to N , the type of the related feature is found according to the bounding box bnd_{2D} and the area of face f according to five rules:

Rule 1. A face f_{Ni} that is made of less than three different vertices is of type *Feat2d_Nothing*.

Rule 2. A face f_{Ni} that has two vertices on a border of bnd_{2D} is of type *Feat2d_Groove*.

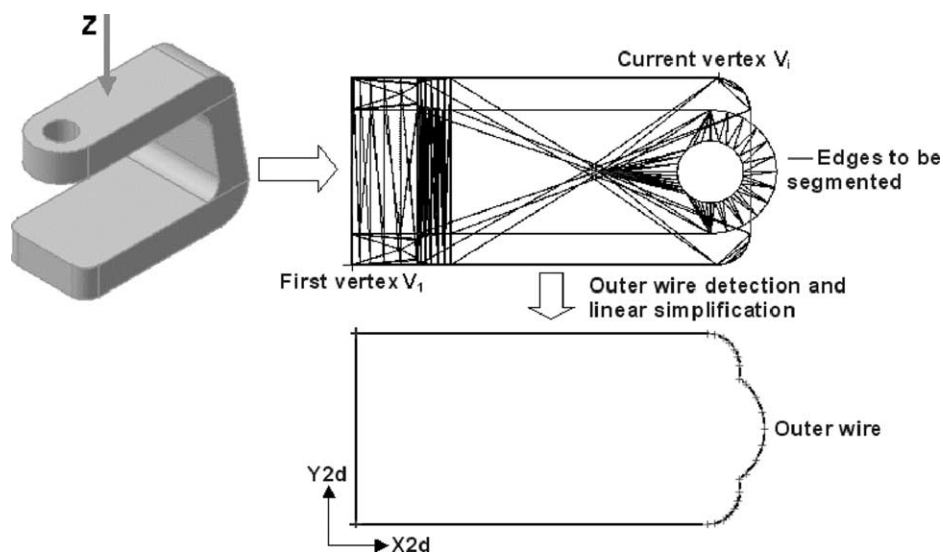

Fig. 6. Projection of a faceted B-Rep model onto a plane and extraction of its outer-wire.

Rule 3. A face f_{Ni} that has three vertices on a border of bnd_{2D} is of type *Feat2d_Step*.

Rule 4. A face f_{Ni} that has only 1, or more than three vertices on a border of bnd_{2D} is of type *Feat2d_Other*.

Rule 5. A feature, of the type different to *Feat2d_Nothing*, and with an area inferior to 0.01 times the area of the face f , becomes type *Feat2d_Other*.

Fig. 7 shows step-by-step application of the described procedure and its associated rules; three features are identified. Features numbered 1 and 2 are recognized as steps (*Feat2d_Step*) whereas number 3 is of type ‘other’ (*Feat2d_Other*). It would have been of type groove (*Feat2d_Groove*) had its area been superior to 0.01 times the area of f . In the case of a more geometrically complex part, a classical shape healing algorithm [26] is applied to each face f_{Ni} in order to make a polyhedral approximation on the original B-Rep model. Fig. 8 shows the effect of using an algorithm of this type.

For a non-rotational part, this recognition step is performed for each of the three projections *ProjX*, *ProjY* and *ProjZ*. For a rotational part however, computing these three projections makes no sense. Indeed, the feature recognition process serves only as input for the orientation problem. Boothroyd–Dewhurst’s criteria are based on relationships between α and β symmetries and the features. For α symmetry, none of the three

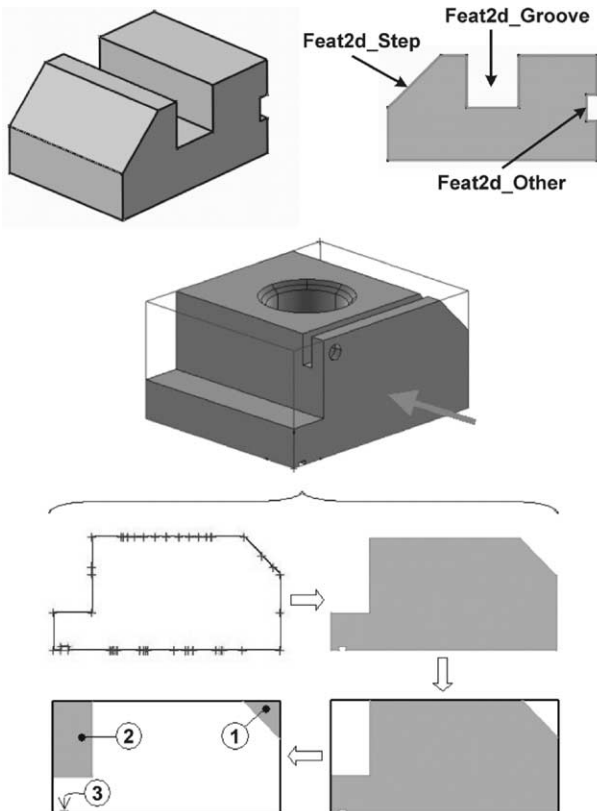

Fig. 7. 2D features detection.

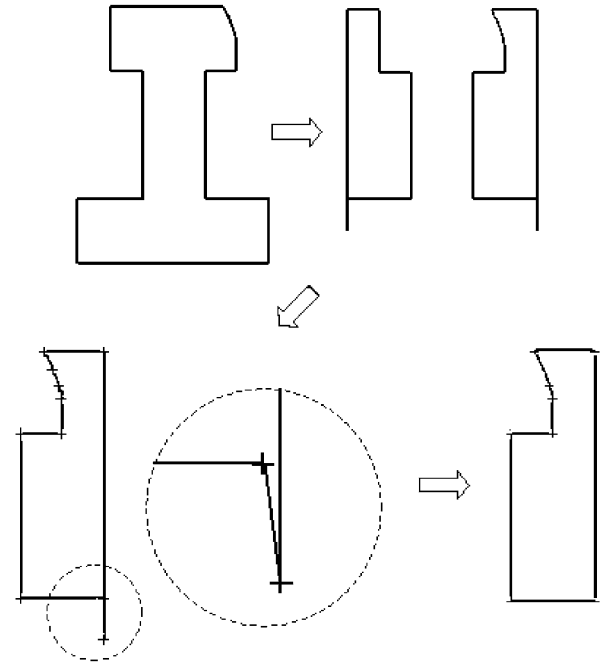

Fig. 8. Effect of polyhedral shape healing process.

projections provide reliable information (Fig. 9). But, the 2D features found on *ProjX* or *ProjY* are of interest for β symmetry.

In the general case however, *ProjX* and *ProjY* are different. The projection Proj^* is defined as:

$$\text{Proj}^* = \text{ProjX} \cup \bigcup_{i=0}^n \text{Proj}_{\text{Feat}3D_i} \quad (2)$$

where $\text{Proj}_{\text{Feat}3D_i}$, the projection of each 3D feature along X , is used to find the β symmetric features. Thus, the feature recognition process for a rotational part must first identify the 3D features. Fig. 10 shows how to find Proj^* for a sample part:

1. 3D features identification,
2. projection of each 3D feature along the projection axis,
3. union of all the projections.

Lastly, a feature selection test is performed in order to avoid counting the β symmetric features twice. This test consists in deleting each feature that has vertices of its

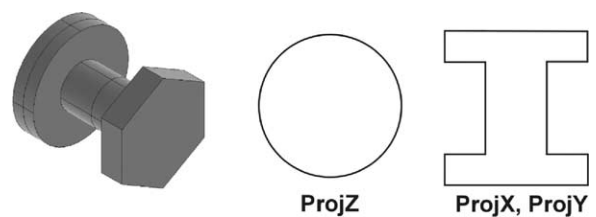

Fig. 9. Three projections of a part.

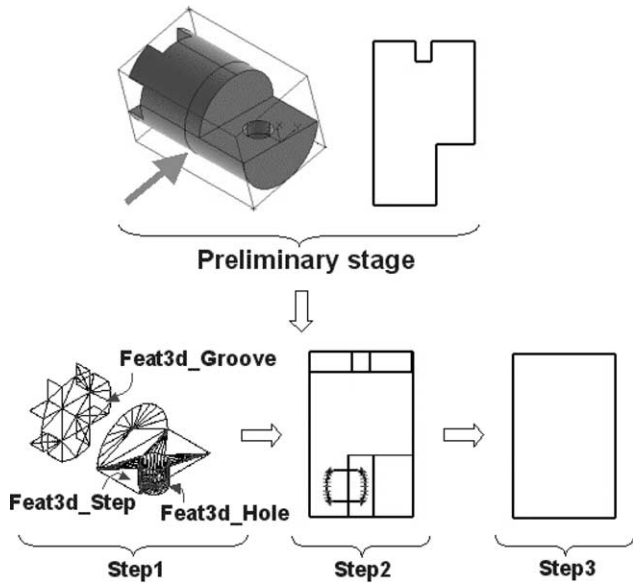

Fig. 10. Pre-processing for the 2D projection of a rotational part.

symmetric, along the insertion axis, which are included in another feature. Fig. 11 shows this process.

5.2. 3D feature recognition

For the sake of simplicity, the proposed approach uses different recognition techniques depending whether the part

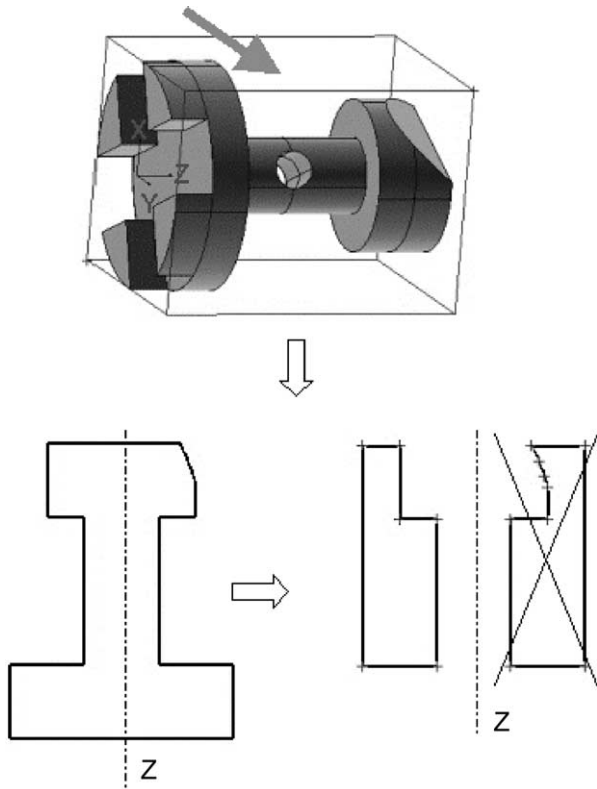

Fig. 11. Reduction of the number of 2D features for a rotational part.

is rotational or not. Five types of features are identified: *Feat3d_Step* (steps, bosses, notches, chamfers and fillets), *Feat3d_Groove*, *Feat3d_Cavity* (holes and pockets), *Feat3d_Other* and *Feat3d_Nothing*. First, faces that are candidates to form a feature are gathered. Three algorithms were implemented in order to detect the maximum number of features:

1. An inner loop-based algorithm,
2. A vertex vexity-based algorithm,
3. A local topology analyzer.

Then, a rule-based identification process was applied to every feature in order to determine its type. All the 3D features of a part were gathered in the set $F3d$. From general methods [13], the authors developed original recognition methods or used known methods such as the inner loop-based algorithm. The inner loop-based algorithm recognition process aims to find features of type *Feat3d_Cavity*. Faces in contact with an inner loop of a face are candidates to form such a feature (Fig. 12).

The vertex vexity-based technique, an original method, complements the original ‘edge vexity based’ method developed from the general method described by Parry-Barwick and Bowyer [13]. The vertex vexity-based technique allows the detection of steps, notches and grooves. The algorithm begins searching the outer wire W of each face f . Then, W and the underlying parametric surface S of f allow definition of $W2d$, the outer wire of f in the parametric coordinate system (u, v) of S . At this point, concave vertices in $W2d$ are gathered

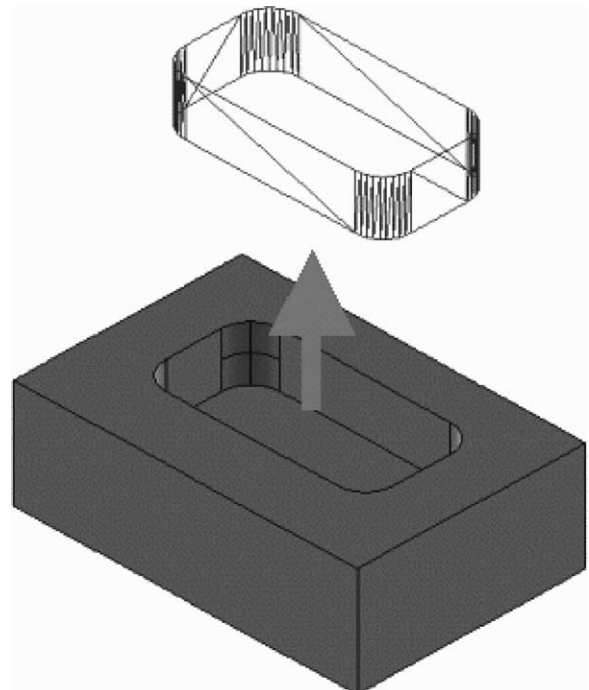

Fig. 12. A pocket feature in a non-rotational part.

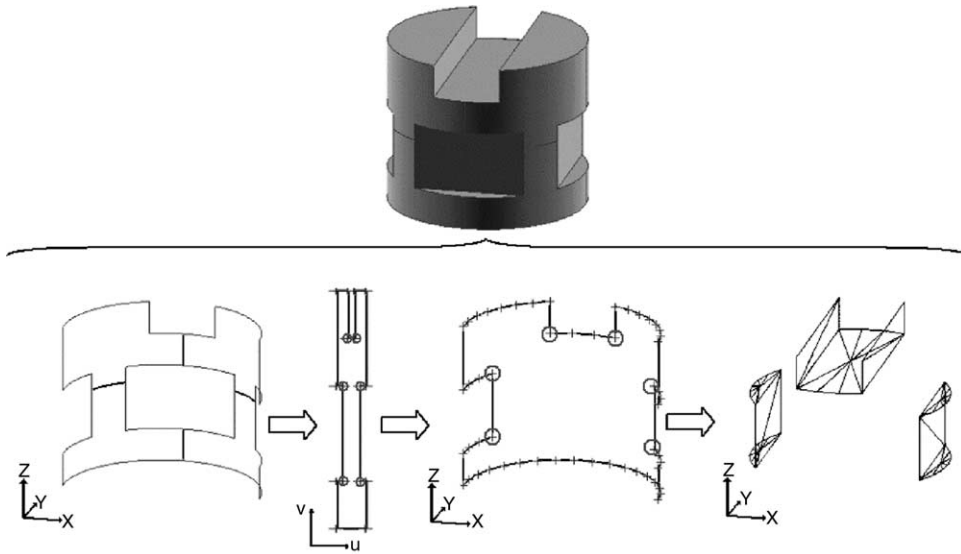

Fig. 13. Vertex vexity-based recognition.

in the set $V2d$ (Fig. 13). Then, for each vertex $V2d_i$ in $V2d$, both edges sharing V_j , i.e. $E_j(V_{j-1}, V_j)$ and $E_{j+1}(V_j, V_{j+1})$, where V_j is the vertex in W that corresponds to $V2d_i$, are selected.

Faces of the part sharing E_j or E_{j+1} are gathered to form a partial feature. This procedure is reproduced while there are vertices left in V . Finally, features sharing a face are fused and the resulting features are appended to $F3d$. This algorithm uses the faceted B-Rep model of the part. This technique avoids studying, in the exact B-Rep model, inflexion points of the underlying geometric curve of each edge. However, this approach does not limit the feature recognition process. Indeed, at each inflexion point in the underlying geometric curve of an edge, lies a corresponding vertex of the same edge in the faceted model. Furthermore, if there is at least one concave vertex, whatever the model is, the face that contains this vertex is selected. There is no partition of faces along edges for which the second derivative vectors (along u and v axes), on the underlying geometric surface, are null. In general, the partition of a shape, whatever its topological type, involves topological modifications in the data structure of the part. This would lead to problems that are beyond the scope of this paper. It should be noted that such considerations have little interest in assembly since complex surfaces always get the poorest assemblability score. The latter have little sense in manufacturing also, since the more appropriate process for making a complex surface is a five-axis milling cycle, and decomposing this cycle into several similar cycles is usually redundant.

The inner loop-based algorithm is convenient to find cavities and bosses. The vertex vexity-based algorithm is more general and thus capable of detecting even more features, such as grooves and notches. However, neither

of these algorithms ensures the detection of chamfers and fillets in a part. Consequently, an original local topology analyser has been implemented. This analyser uses less time than the approaches presented in other works for manufacturing or design applications [27]. For example, in manufacturing applications blend radii could provide information that aids in selection of tools during machining and in the design application of blend recognition. Suppression is used for clean up operations in Finite Element Analysis. Often, in an assembly application, an analyser for detecting fillets and chamfers is less complicated. This local analyzer computes material angles for each face candidate to form a chamfer or a fillet. These faces are deduced from the GF_{PLN} and F_{REV} sets created when the minimal bounding box was searched. In each sub-set of GF_{PLN} and F_{REV} , a face not linked to another face is a candidate to form a chamfer. Sub-sets containing two conical (toroidal) faces in F_{REV} undergo a specific process as they may form a chamfer (fillet). Lastly, each valid chamfer or fillet is added to the 3D feature set $F3d$.

For each feature in $F3d$ the following type identification algorithm is applied:

1. Type of each face in $F3d_i$ is selected among *planar*, *rotational* (cylindrical, spherical, conical, toroidal or of revolution) and *other* (B-Spline, of extrusion or offset),
2. Numbers of faces for each of the above defined types are computed and are respectively named nb_pln , nb_rev and nb_oth ,
3. In each face in $F3d_i$, numbers of free edges and constrained edges (in contact with another face in $F3d_i$) are computed,
4. Number of faces, for which all edges are constrained, is computed,

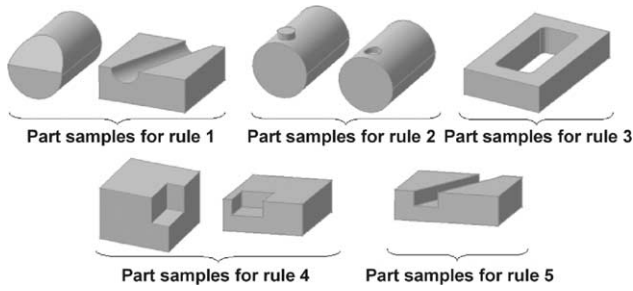

Fig. 14. Part samples for identification rules.

5. Five rules are then applied in order to identify the type of $F3d_i$:

Rule 1. If there is only one face:

- If the face type is planar, then the feature type is Feat3d_Step.
- If the face is cylindrical or other, the feature type is Feat3d_Step or Feat3d_Groove depending on the location of the material.

Rule 2. If there is one face of which all edges are constrained then the type is Feat3d_Step (boss) or Feat3d_Cavity (blind hole or pocket) depending on the location of the material.

Rule 3. If each face has two constrained edges then the type is Feat3d_Cavity (hole or pocket through all).

Rule 4. If the proportion of constrained edges (number of constrained edges/total number of edges) in each face is ≥ 0.5 then the type is Feat3d_Step (notch).

Rule 5. If the proportion of free edges (number of free edges / total number of edges) in each face is ≥ 0.5 then the type is Feat3d_Groove.

Illustrations of each rule are provided in Fig. 14.

For rotational parts, feature location is relevant to compute the orientation efficiency and a decision must be taken concerning whether a feature is located only on side faces of the part, or on both end and side faces or only on end faces. In order to remove any ambiguity, a fuzzy model representing the feature location was created as a function of the ratio L/D , where L is the depth of the feature and D the diameter of the cylindrical bounding box of the part. Dealing with uncertain knowledge calls for the use of the fuzzy decision support system implemented in *FuzzyDFA*. Fig. 15 shows the fuzzy representation adopted for feature location as well as part samples. The x -axis represents the R ratio L/D , and the y -axis the level of membership values between 0 and 100%. Using part number 2 as an example, the feature location is 50% 'only on end faces' and 50% 'on both end and side faces'.

According to the rules defined in Fig. 15, Table 2 provides the fuzzy location of the groove for each part sample. During the DFA evaluation process,

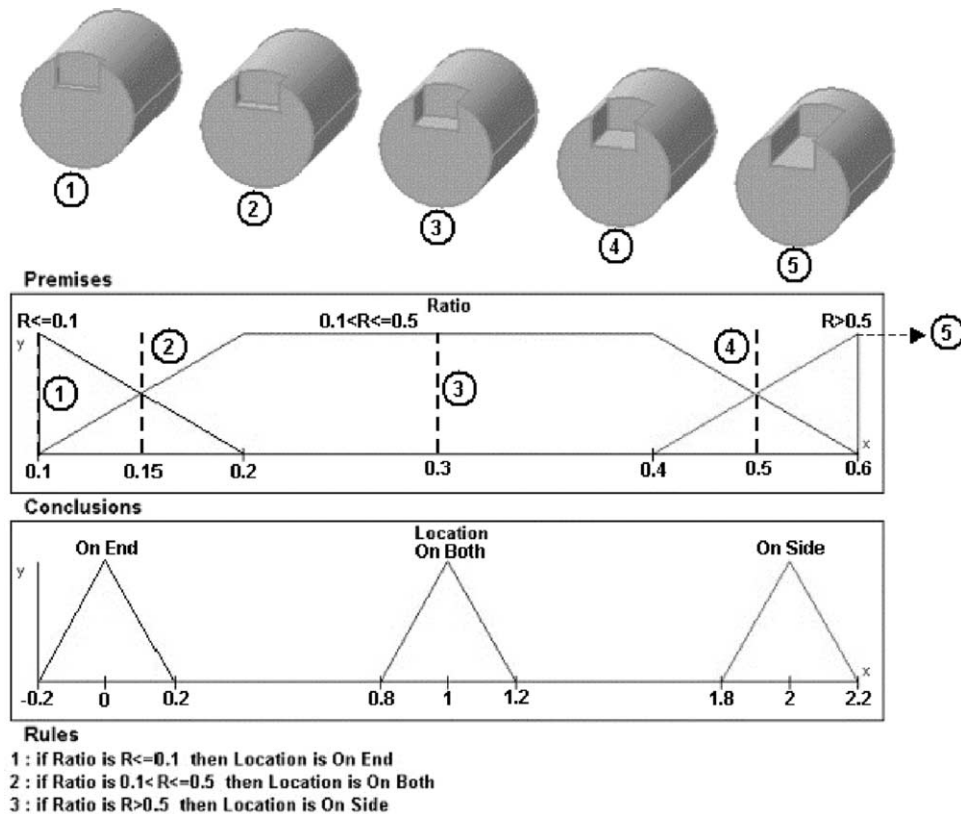

Fig. 15. Part samples and fuzzy representation of the feature location.

Table 2
Fuzzy location for part samples in Fig. 15

Part number	Ratio R	Location
1	0.10	100% 'only on end faces'
2	0.15	50% 'only on end faces' and 50% 'on both end and side faces'
3	0.30	100% 'on both end and side faces'
4	0.45	50% 'on both end and side faces' and 50% 'only on side faces'
5	0.80	100% 'only on side faces'

the orientation efficiency is computed by weighting, for each feature, results obtained for the three locations by the fuzzy location.

5.3. Measuring 3D feature size

Retrieving the volume of a feature in $F3d$ is not an easy task. The features recognized above are made of faces that do not represent a closed shell. Therefore a reconstruction algorithm must be applied in order to create a convex closed shell that is significant in terms of manufacturing. This problem is complex however, and implies the addition of topological entities (like vertices, edges and faces) in the data structure of the part. Moreover, there is a need for rules to construct such entities. For example, Fig. 16 shows three different solutions for filling a groove. Falcidieno and Giannini [28] introduce the notion of dummy entities similar to the notion of virtual entities defined by Brun [29]. In this paper the technique described by Brun [29] is used to build a convex closed shell for a feature from local topology.

Feature size is a measure that is only used to order 3D features by importance for DFA. Furthermore, in the feature selection process that defines part orientation, this measure is only relevant when several features have the same capabilities for orienting the part. In this case, the feature of maximum measured value must be selected. In order to overtake the volume retrieval issue the selected measure is the area of the plane-projected feature along its axis. The axis of a feature depends on the feature type. For example, the axis direction of a groove is the normal vector of the bottom face.

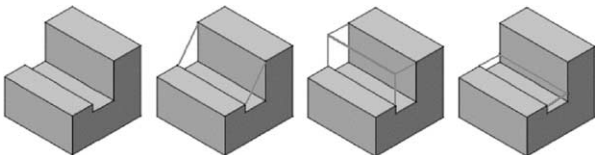

Fig. 16. Topological entities to be added to fill a groove.

6. Part orientation

This section discusses the definition of an optimal part orientation as it relates to DFA methodology. Boothroyd–Dewhurst uses OE , the orientation efficiency, and FC , the relative cost of the bowl feeder, to characterize part orientation. The following approach selects features maximizing the objective function $F_{obj} = OE/FC$, analyzing 2D and 3D features orientation capabilities. The orientation is optimal in terms of OE and FC values.

6.1. Feature orientation capabilities

In order to define the part orientation, the proposed algorithm evaluates the inner symmetries and searches for symmetric features for each 2D feature in a 2D projection and for each 3D feature in the part. Six symmetry attributes ($symX$, $symY$, $symZ$, has_symX , has_symY , has_symZ) are therefore added to the 2D and 3D feature data structures, as well as the feature usefulness.

2D feature orientation capabilities. Fig. 17 shows the meaning of these symmetries for 2D features.

For the 2D projection on the left in Fig. 17:

- 1 has X inner symmetry ($symX$),
- 2 has Y inner symmetry ($symY$).

For the 2D projection on the right in Fig. 17, attributes has_symX , has_symY and has_symZ are true for features 1, 2, 3 and 4.

Symmetry $symZ$ is not of interest for 2D features. According to the given definitions, no 2D feature can be $symZ$ symmetry. Only features of type 'hole' or 'cavity' could have been $symZ$ symmetry but they are not used in this approach due to their insignificance in the DFA methodology. Furthermore, only 'hole' or 'cavity' features could have been both $symX$ and $symY$ inner symmetries. Table 3 gives an indication of $F2d_{ik}$ capabilities, the k th feature of the projection i , where $i \in \{X, Y, Z\}$, depending on the number of its inner symmetries and the number of its symmetric features.

In Table 3, a case 2 feature, having one inner symmetry and one symmetric feature, is a feature that has one

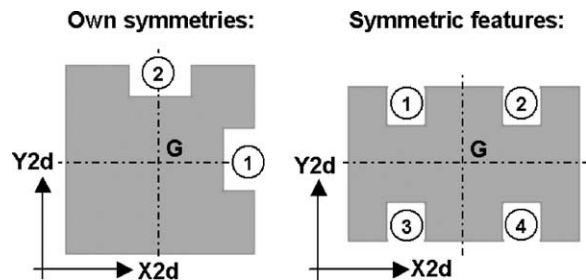

Fig. 17. Symmetries used to define the projection orientation.

Table 3
Orientation capabilities for a 2D feature

No.	Number of own symmetries	Number of symmetric features	Properties
1	0	0	Orients the part
2	0	1	This feature removes two rotation axes for the part
	1	0	
	1	1	
3	0,1	2	This feature and one of these symmetric features orient the part
4	0,1	3	This feature is useless
5	2	0,1,2, or 3	Impossible

symmetric feature around Z (i.e. $G2d_i$), and hence, this feature is case 2. Fig. 18 shows part samples for each case.

When a feature is quoted as useless (case 4 in Table 3), a specific case is taken into consideration: if the 2D bounding box of the 2D projection is squared and if this feature is a groove, then it is useful and is case 2 in Table 3, as it has a $G2d$ -symmetric feature (i.e. its attribute *has_symZ* is true).

Lastly, if $F2d_{ik}$ is case 2 in Table 3, a 3D characteristic axis, named $Axis_{3D}$, is defined as the axis around which the part can be 180° -rotated so the face representing the projection i stays the same before and after this rotation. Table 4 provides the $F2d_{ik}Axis_{3D}$ value, which is one of the 3D coordinate systems of the minimal bounding box, corresponding to a symmetry axis (inner symmetry and/or symmetric feature) of $F2d_{ik}$.

3D feature orientation capabilities. Table 5 presents $F3d_i$ capabilities, depending on the number of its inner symmetries and the number of its symmetric features. Fig. 19 shows part samples for each case.

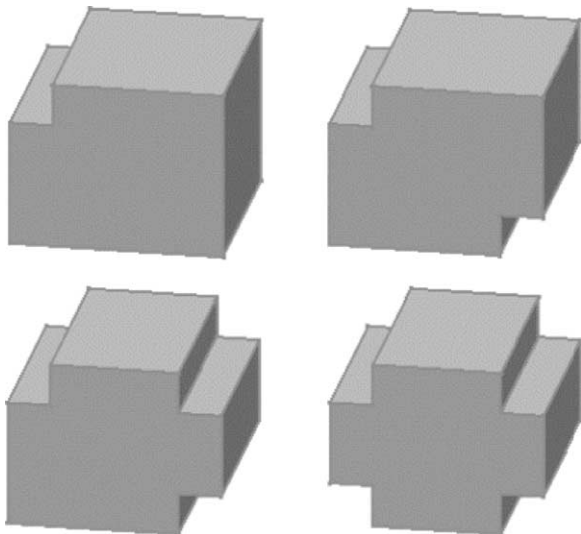

Fig. 18. Part samples for cases 1, 2, 3 and 4 in Table 3 from the left to the right.

Table 4
Connection between 2D and 3D coordinate systems

Projection name	2D symmetry axis	3D axis
ProjX	$X2d$	Y'
	$Y2d$	Z'
	$G2d$	X'
ProjY	$X2d$	X'
	$Y2d$	Z'
	$G2d$	Y'
ProjZ	$X2d$	X'
	$Y2d$	Y'
	$G2d$	Z'

6.2. Orientation for a non-rotational part

Ideally, a part would not require any feature to define its orientation so the distribution would have no mechanical selection. However, use of features is usually required. The system therefore attempts to bring the number of features

Table 5
Orientation capabilities for a 3D feature

No.	Number of own symmetries	Number of symmetric features	Properties
1	0	0	Orients the part
2	0	1	This feature removes two rotation axes for the part
	1	0	
3	0	2	This feature and one of these symmetric features orient the part
4	0	3	This feature is useless except for cubic part
	1	1	
	2,3	0	
5	1	2,3	Impossible
	2,3	1,2,3	

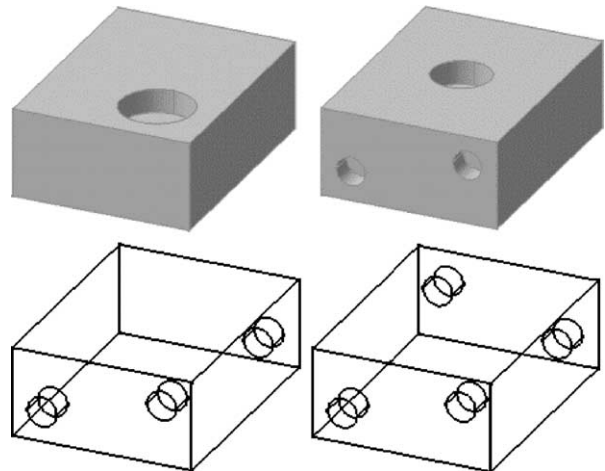

Fig. 19. Part samples for cases 1, 2, 3 and 4 in Table 5 from the left to the right.

down to a minimum. Steps and grooves are detected in 2D projections. The type of each 3D feature is assigned `Feat3d_Cavity`, assuming that whenever a feature is not visible in any 2D projection, whatever its actual type is, the part is as complex to orient as if it had a blind hole.

According to features capabilities, it can be established that 0, 1 or 2 features can define the orientation for a non-rotational part. The part orientation is completely defined whenever the part is superimposed on itself before and after a 180° -rotation around the X , Y or Z axis of its minimal bounding box. The following rules, summarizing all possible cases, help understand this purpose.

Rule 1. A useful 2D or 3D feature that has neither inner symmetry nor a symmetric feature can orient the part (Tables 3 or 5, case 1). The part orientation can thus be defined by only one feature.

Rule 2. If there is one axis U left, where U is one of the three minimal bounding box axes around which the part can still be rotated, we search for either a 2D feature, without U as $Axis_{3D}$, or a 3D feature, without U as an inner symmetry axis and without a U -symmetric feature to complete the definition of the part orientation.

Rule 2 uses features that correspond to case 2 in Tables 3 and 5. This rule means that two features can define the part orientation: two 2D features, or one 2D feature and one 3D feature, or two 3D features.

Rule 3. If a feature removes one or two rotation axes, i.e. there are axes left around which the part can still be rotated, and if none of the other features can remove these axes, then the part can be oriented by this sole feature.

Rule 4. If no feature is able to remove any axis, then the part is naturally oriented by its bounding box shape.

In the following section, features are ordered to select the most easy-to-use features for designing mechanical selections. The orientation process goes on until an orientation solution is found. First, an attempt to orient the part without using features of type *other* is performed. If this attempt fails, features of type *other* can participate in defining the part orientation. Each of these two attempts searches for an orientation solution using either one 2D projection, or two 2D projections, or one 3D feature, or one 2D feature and one 3D feature, or two 3D features. These criteria use rules 1 and 2, and are ordered by increasing technological difficulty. A failure of this second attempt means that the part might be oriented by only one 2D or 3D feature (rule 3). Lastly, if the former fails, the part requires no feature to define its orientation (rule 4).

Whenever two features are used to orient the part, the type and axis of the main DFA feature for defining the part orientation are those of the feature of minimum F_{obj} value. Once the part orientation is defined, corresponding row and column indices, deduced from the fifth to seventh Tables of the B-D's DFA technique, are computed to allow DFA evaluations to be performed.

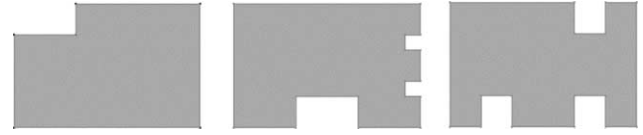

Fig. 20. Projection samples for cases a, b-1, b-2 from the left to the right.

Part orientation with one 2D projection. In each projection i , 2D features are ordered by decreasing F_{obj} value and decreasing size. Projection samples for the following cases are given in Fig. 20:

- (a) Search for a useful 2D feature compliant to rule 1 (case 1 in Table 3),
- (b) If no such 2D feature is found, search for a couple of useful 2D features ($F2d_{ik}, F2d_{il}$) that can orient the part:
 - (b)-1 $F2d_{ik}$ and $F2d_{il}$ do not have the same $Axis_{3D}$ value (rule 2),
 - (b)-2 Or, $F2d_{ik}$ and $F2d_{il}$ are case 3 in Table 3.

Part orientation with two 2D projections. From this point, each projection has only 2D features that are case 2 or 4 in Table 3. For each couple ($ProjX, ProjY$), ($ProjY, ProjZ$) and ($ProjZ, ProjX$), we search for a couple of two useful 2D features ($F2d_{ik}, F2d_{jl}$), $i \neq j$, i.e. one feature on each projection, for which $F2d_{ik}Axis_{3D} \neq F2d_{jl}Axis_{3D}$, that maximizes the orientation efficiency (rule 2). For example, the part in Fig. 21 is oriented by both grooves (located in two different projections), which have different $Axis_{3D}$ values.

Part orientation with one 3D feature. 3D features are ordered by decreasing value of their projected area. Then,

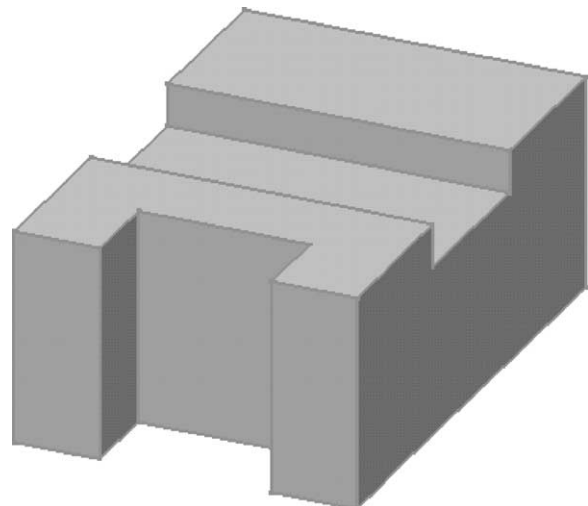

Fig. 21. Part sample for which orientation is defined by two projections.

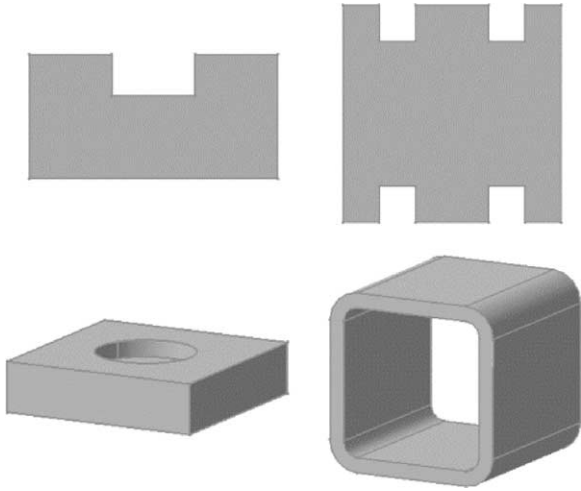

Fig. 22. Projection and part samples for cases a-1, a-2, b-1, b-2 from the left to the right.

we search for a useful 3D feature compliant to rule 1 (case 1 in Table 5).

Part orientation with one 2D feature and one 3D feature. The technique consists of analyzing orientation capabilities of each couple $(F2d_{ik}, F3d_j)$ following rule 2.

Part orientation with two 3D features. From this point, each 3D feature is case 2 or 4 in Table 5. The technique consists of analyzing orientation capabilities of each couple $(F3d_i, F3d_j)$ following rule 2.

Part orientation with one 2D feature or one 3D feature. This attempt to orient the part consists of analyzing if one feature (2D or 3D), previously considered to partially orient the part, can then orient the part, since the part has no feature capable of completing the partial orientation of this feature. The implemented technique verifies the orientation capabilities of 2D projections and 3D features (Fig. 22).

- (a) For each 2D projection $Proj_i$
 - (a)-1
Its bounding box is rectangular: if $Proj_i$ is symmetric around G_{2d_i} , then no 2D feature in $Proj_i$ can define the part orientation, else the useful 2D feature of maximum F_{obj} value is selected,
 - (a)-2
Its bounding box is squared: if $Proj_i$ is superimposed onto $Proj_i$ rotated around $(G_i, 90^\circ)$, then no 2D feature in $Proj_i$ can define the part orientation, else the useful 2D feature of maximal F_{obj} value is selected,
- (b) For each 3D feature $F3d_i$:
 - (b)-1
The part is not cubic: if $F3d_i$ is useful then it can orient the part.
 - (b)-2
The part is cubic: $F3d_i$ can orient the part.

6.3. Orientation for a rotational part

The following describes the implemented geometric interpretations of Boothroyd–Dewhurst Table criteria to orient a rotational part.

Retrieving indices of valid rows and valid columns are two independent steps. Therefore, the technique consists in optimizing the objective function F_{obj} while studying every couple (row, column) that is a suitable orientation solution. The overall algorithm is described below:

- Search for index of valid rows that define the set R ,
- Search for index of valid columns that define the set C ,
- Computation of F_{obj} for every couple (R_i, C_j) ,
- N_R and N_C are indices of the couple for which F_{obj} is maximum.

Retrieving valid rows. The index of each row for which the part is compliant is added to the set R . Criteria for the eight rows are:

Row 0: ‘The part is α symmetric’.

Studying other rows becomes useless since F_{obj} is always optimal in row 0.

Row 1: ‘The part can be fed in a slot supported by large end (step feature) or protruding flange (chambered step feature) with its centre of mass below the supporting faces’.

The 2D projection is used to verify compliance to this rule:

- Part centre of mass is projected onto this projection (G_{2D}),
- Features of type $Feat2d_Step$ for which at least one vertex is on the bottom edge E of the projection bounding box are gathered in the set $Feat2d$,
- For each feature in $Feat2d_i$, we search for V_F , the farthest vertex from E that belongs to the feature. If V_F is located above G_{2D} along the Z axis then this feature validates the rule (Fig. 23).

Row 2: ‘ β symmetric steps or chambers’.

If there is at least one β symmetric feature of type $Feat2d_Step$ then the part conforms to this rule.

Row 3: ‘ β symmetric grooves, holes or pockets on both end and side faces’.

If there is at least one β symmetric feature of type $Feat2d_Step$, $Feat3d_Groove$ or $Feat3d_Cavity$ located on both end faces and side faces then the part conforms to this rule.

Row 4 (5–6): ‘ β symmetric grooves, holes or pockets only on side (end) faces’.

If there is at least one β symmetric feature of type $Feat2d_Step$, $Feat3d_Groove$ or $Feat3d_Cavity$ located on side (end) faces, then the part conforms to this rule. Criterion in row 6 is difficult to compute but, as it is close to row 5 criterion, row 6 is ignored in the developed approach.

Row 7: ‘ β asymmetric features’.

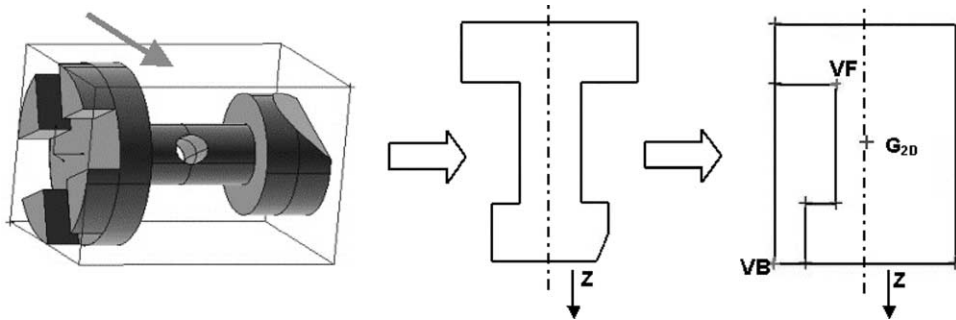

Fig. 23. Part sample that conforms row 1.

This row means that the part has some features but none of them is able to orient the part relative to its end faces.

Row 8: 'Small size features'.

All the features in the part are too small to be used by an automated assembly system. This row is added to R only if R is empty.

For the part in Fig. 23, $R = \{1, 2, 3, 4, 5, 7\}$. Indices 1 and 2 are from the β symmetric step. The β symmetric hole allows the addition of index 4, the β symmetric groove indices 3 and 5 (due to its fuzzy location), and the β asymmetric step index 7.

Retrieving valid columns. The index of each column for which the part is compliant is added to the set C . Criteria for the eight columns are:

Column 0: 'The part is β symmetric'.

Studying other columns is useless since $Fobj$ is always optimal in column 0.

Column 2 (3): ' β asymmetric bosses, steps or chambers located only on side (end) faces'.

The part conforms to this rule if there is at least one β asymmetric feature of type $Feat2d_Step$ or $Feat3d_Step$ located only on side (end) faces.

Column 4: 'Same criterion as in column 2 and 3 but features are located on both side and end faces'.

Column 5: ' β asymmetric grooves visible on a view along Z axis'.

The part conforms to this rule if among the 3D grooves, the axis of one of them is collinear to Z .

Column 6(7): ' β asymmetric grooves, visible on a side view, located on end (side) faces'.

The part conforms to this rule if there is at least one β asymmetric feature of type $Feat2d_Groove$ or $Feat3d_Groove$ located only on end (side) faces.

Column 8: 'Small size features'.

All the features in the part are too small to be used by an automatic assembly system. This column is added to C only if C is empty.

For the part in Fig. 23, there is only one β asymmetric feature: it is the chamfer ($Feat3d_Step$) located on end

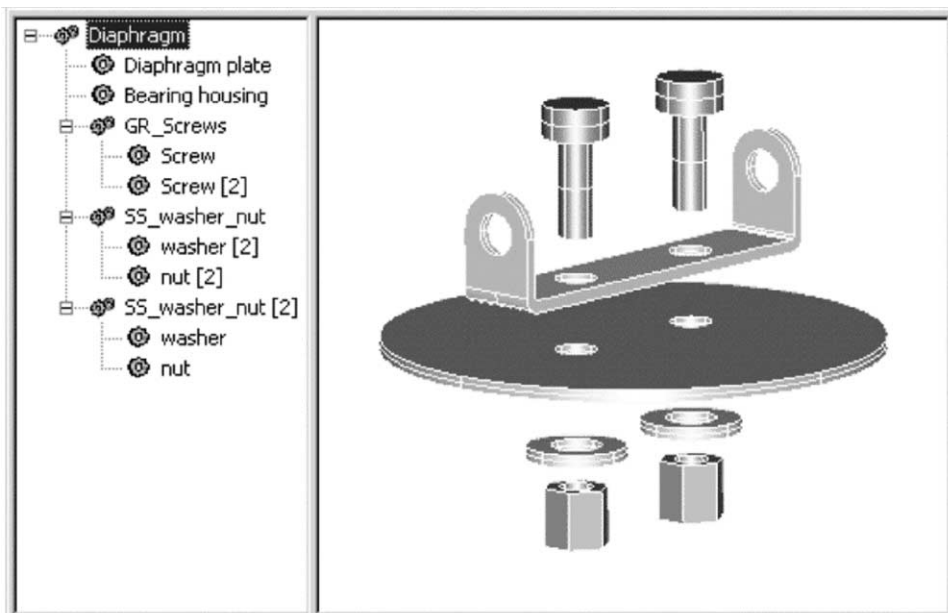
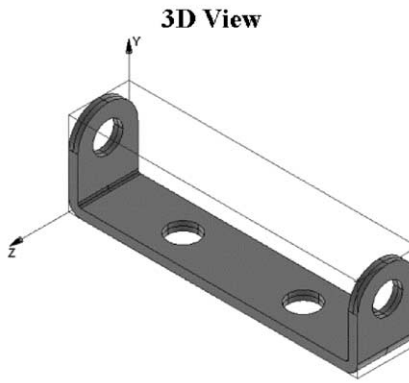





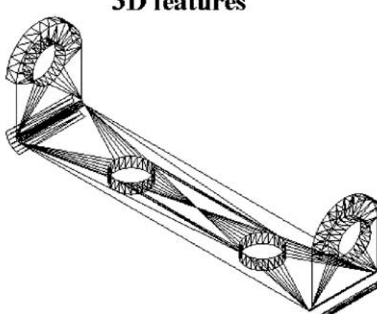

Fig. 24. Assembly sample: a diaphragm.

Table 6
Geometric analysis of the bearing housing

Part: Bearing housing		
<p style="text-align: center;">3D View</p> 		
Projection	Face	Negative
X		
Y		
Z		
<p style="text-align: center;">3D features</p> 		

faces, and hence $C = \{3, 4\}$. Then, evaluation for couple (1,3), (2,3), (4,3), (7,3), (1,4), (2,4), (4,4), (7,4) are computed. Finally, a couple (1,3), that maximizes $Fobj$, is selected, i.e. the part can be oriented by the β symmetric step and the β asymmetric chamfer.

7. Case study

The assembly sample created in *FuzzyDFA* (Fig. 24) is a diaphragm to be assembled in automated operations.

When a designer computes an assembly evaluation each part is first assessed individually. Only geometric results are presented here. In the diaphragm, the bearing housing has the most complex geometry. Table 6 summarizes features found in the bearing housing geometry.

ProjX has two symmetric step features. $Axis_{3D}$ of each of them is Y .

ProjY has no features.

ProjZ has one groove feature, for which $Axis_{3D}$ is Y , and two features of type other (two small size steps), for which $Axis_{3D}$ is Y .

There are four 3D holes and four 3D fillets, each of them having an Y symmetric feature. Lastly, the 3D groove has one inner Y symmetry.

In this part, neither one feature nor a feature combination can block the Y axis. However, the part can be oriented by one *ProjX* 2D step, i.e. the feature that has the best $Fobj$ value.

For the sake of simplicity, only a brief description of the orientation solution for other parts follows:

Diaphragm plate. It can be oriented by one 3D hole feature,

Screw. It can be supported by its large flange (row 1) and it is β -symmetric (column 0),

Washer. It is α and β -symmetric,

Nut. It is α and β -symmetric.

Considering that technological and assembly characteristics of each part have already been input in *FuzzyDFA*, the assembly evaluation can then be computed for the diaphragm. In this case the assembly efficiency is only 28%. The user must therefore reconsider the part's design to improve the assemblability of this product.

8. Conclusion

FuzzyDFA was built in Visual C++ and Open CASCADE™ 3.1 [30], which is a powerful 3D modeling kernel that consists of reusable C++ object libraries available as Open Source. *FuzzyDFA* enables the creation of 3D assemblies as well as the DFA definition of each part, assuming that its geometry has already been modeled as per the STEP AP203 standard. DFA evaluation can be computed either on a time/cost basis or on a merit scale, for manual and automated operations.

This paper has defined most of the geometric information required for DFA. Weight, dimensions and symmetries are sufficient characteristics for computations in manual operations. For automated assemblies, the proposed approach focuses on the usage of bowl feeders, which were investigated in depth by Boothroyd–Dewhurst. These devices operate on the 2D projected form features of a part. A feature recognition tool is detailed in this paper as well as an original approach for defining the orientation of a part. The usage of two geometric models (exact B-Rep and faceted B-Rep) allows algorithmic effectiveness, using the advantages of both models while avoiding their drawbacks. Every geometric characteristic serves as an input for the fuzzy decision support system used in *FuzzyDFA*. In this way, *FuzzyDFA* intelligently automates the assembly

evaluation process by minimizing designer inputs. This use of fuzzy logic allows evaluation of each part in a product to be performed early in the design process even if the part design is not detailed enough or remains uncertain.

9. Future work

The corrective knowledge base is being implemented and will provide a rationale and suggestions for improving the design of every part. A major enhancement to *FuzzyDFA* would be the addition of an assembly/disassembly sequencing system that analyzes contacts and mobility of parts. Insertion axes of parts would be automatically found [31] and this would further reduce the number of user inputs required. Appending assembly features to the component data structure [12] would even more improve the evaluation process, taking into consideration, at each stage of the assembly process, functional data in addition to geometric, technological and assembly data.

Further enhancements could focus on the development of additional concurrent engineering tools that use DFX methodologies, where *X* stands for any product life cycle phase. Technically, this would imply the use of multiple-view models [32], which would deal, for each part, with a master model and different engineering views articulated around it. This hypothetical approach would also be able to deal with enhanced multi-views features [33]—such as a form feature or a feature with a functional meaning at a higher abstraction level and appropriate recognition algorithms. Finally, a dedicated information system would manage all the product model data at a higher level [34]. All these enhancements would transform *FuzzyDFA* into a more general computer-aided design tool.

References

- [1] Tollenaere M. Conception de produits mécaniques. Hermes, ISBN 2-86601-694-7; 1998.
- [2] Boothroyd G, Dewhurst P, Knight W. Product design for manufacture and assembly. New York: Marcel Dekker; 1994. ISBN 0824791762.
- [3] Coma O, Mascle C, Véron P, Moisan S. Application de la logique floue à une méthode de conception pour l'assemblage. Fourth International Industrial Engineering Conference, Aix-Marseille; 2001. p. 109–18.
- [4] Coma O, Mascle C, Véron P. Feature shape recognition tools dedicated to a design for assembly methodology. Proceedings of the Fourth International Conference on Integrated Design and Manufacturing in Mechanical Engineering, Clermont-Ferrand, France; May 14–16 2002.
- [5] Ames AL. Production ready feature recognition based automatic group technology part coding. Proceedings of the First Symposium on Solid Modelling Foundations and CAD/CAM Applications; 1991. p. 161–9.
- [6] Li R-K, Hwang C-L. A framework for automatic DFA system development. *Comput Ind Engng* 1992;22(4):403–13.
- [7] Ong NS, Lye SW. Geometric analysis of component design for assembly. *J Des Manufact* 1992;2(3):135–41.
- [8] Rosario M. Automatic geometric part features calculation for design for assembly analysis. PhD Dissertation. University of Rhode Island; 1988.
- [9] Sturges R, Kilani M. Towards an integrated design for an assembly evaluation and reasoning system. *Comput Aided Des* 1992;24(2): 67–79.
- [10] Han J, Pratt M, Regli W. Manufacturing feature recognition from solid models: a status report. *IEEE Trans Robot Automat* 2000;16(6): 782–96.
- [11] Ji Q, Marefat M. Machine interpretation of CAD data for manufacturing applications. *ACM Comput Surv* 1985;24(3): 265–311.
- [12] Jabbour T, Mascle C, Maranzana R. A database for the representation of assembly features in mechanical products. *Int J Comput Geometry Appl* 1998;8(5/6):483–507.
- [13] Parry-Barwick S, Bowyer A. Feature technology. University of Bath, Technical Report; January 1993.
- [14] Regli W. Geometric algorithms for recognition of features from solid models. PhD Dissertation. University of Maryland; 1995.
- [15] Febransyah A. A feature-based approach to automating high-level process planning. PhD Dissertation. North Carolina State University; 2001.
- [16] Kyprianou L. Shape classification in computer aided design. PhD Dissertation. University of Cambridge; 1980.
- [17] Lu Y, Gadh T, Tautges TJ. Feature based hex meshing methodology: feature recognition and volume decomposition. *Comput Aided Des* 2001;33(3):221–32.
- [18] Waco DL, Kim YS. Geometric reasoning for machining features using convex decomposition. *Comput Aided Des* 1994;26(6): 477–89.
- [19] Seed GM, Clark DER, Corney JR, Tuttle R, Little G. Object-oriented graph-based geometric feature recognition. *Comput J* 1996;39(9): 808–11.
- [20] Prabhakar S, Henderson MR. Automatic form-feature recognition using neural-network-based techniques on boundary representations of solid models. *Comput Aided Des* 1992;24(7): 381–93.
- [21] Donaldson I, Corney J. Rule-based feature recognition for 2.5D machined components. *Int J Comput Integr Manufact* 1993;6:51–64.
- [22] Martin RR, Stephenson PC. Containment algorithms for objects in rectangular boxes. In: Strasser W, Seidel H-P, editors. Theory and practice of geometric modeling. Berlin: Springer; 1988.
- [23] Tate S, Jared G, Swift K. Detection of symmetry and primary axes in support of proactive design for assembly. Proceedings of the Fifth Symposium on Solid Modeling and Applications, Ann Arbor, USA; 1999. p. 151–8.
- [24] Martin RR, Dutta D. Tools for asymmetry rectification in shape design. *J Syst Engng* 1996;6:98–112.
- [25] Véron P, Léon J-C. Shape preserving polyhedral simplification with bounded error. *Comput Graph* 1998;22(5):565–85.
- [26] Middleditch A. The bug and beyond. *CSG 94 set-theoretic solid modelling techniques and applications*; 1994. p. 1–16.
- [27] Sashikumar V, Milind S. Blend recognition algorithm and applications. Proceedings of the Sixth ACM Symposium on Solid Modeling and Applications, New York: ACM Press; 2001. p. 99–108.
- [28] Falcidieno B, Giannini F. Extraction and organization of form features into a structural boundary model. *Eurographics'87*, Amsterdam: North-Holland; 1987. p. 249–59.
- [29] Brun J-M. From characteristic shape to form features: a recognition strategy. Chapter 10 of advanced CAD/CAM systems, London: Chapman & Hall; 1995. ISBN 0 412 61730 7.
- [30] OpenCASCADE. <http://www.opencascade.com>
- [31] Rejnieri N. Détermination et simulation des opérations d'assemblage lors de la conception de systèmes mécaniques. PhD

Dissertation. Institut National Polytechnique de Grenoble, France; 2000.

- [32] Véron P, Léon J-C. Contribution to a multi-views, multi-representations design framework applied to a preliminary design phase. Proceedings of the Second International Conference on Integrated Design and Manufacturing in Mechanical Engineering, Compiègne, France; 27–29 Mai 1998. p. 1187–95.
- [33] Noort A, Hoek GFM, Bronsvort WF. Integrating part and assembly modelling. *Comput Aided Des* 2002; 34(12):899–912.
- [34] Young B, Canciglieri O, Costa CA, Dorado JM, Zhao J, Cheung WM. Information support in an integrated product development system. Proceedings of the Third International Conference on Integrated Design and Manufacturing in Mechanical Engineering, Montréal; 2000.



O. Coma is a NCSimul R and D engineer at Spring Technologies in France. He received his MScA degree in Mechanical Engineering from École Polytechnique de Montréal in 2002 and his engineering degree from École des Mines d'Alés (France). His research interests include design for assembly, geometric modeling and NC simulation.



C. Mascle is a full professor at Department of Mechanical Engineering, École Polytechnique of Montréal. He received his PhD in Microtechnic Engineering from École polytechnique fédérale of Lausanne, his BSc degree in Mechanical Engineering from École Polytechnique of Montréal, and his engineering degree in Microtechnic from Engineering School of Le Locle (Switzerland). His research interests include assembly and task planning, product life-cycle modeling, design methodology, intelligent CAD, tolerance modeling, and engineering applications of object oriented programming. He is a member of SME.



P. Véron received his PhD in 1997. He is associate professor at the École Nationale Supérieure d'Arts et Métiers (ENSAM) in France and a member of the Information and System Science Laboratory (LSIS), a CNRS unit. His research activity is centered on the development of geometric modelling approaches in the context of a multi-view and integrated design environment. A particular interest is also brought to multisite collaborative design product approaches.