



Science Arts & Métiers (SAM)

is an open access repository that collects the work of Arts et Métiers Institute of Technology researchers and makes it freely available over the web where possible.

This is an author-deposited version published in: <https://sam.ensam.eu>
Handle ID: <http://hdl.handle.net/10985/10322>

To cite this version :

Tudor BALAN, Farid ABED-MERAIM - Numerical Investigation of the Limit Strains in Sheet Forming Involving Bending - In: 9th International Conference on Technology of Plasticity, ICTP 2008, Corée du sud, 2008-09-07 - Proceedings of the 9th International Conference on Technology of Plasticity, ICTP 2008 - 2008

Any correspondence concerning this service should be sent to the repository

Administrator : scienceouverte@ensam.eu



Numerical Investigation of the Limit Strains in Sheet Forming Involving Bending

T. Balan¹, F. Abed-Meraim¹

¹LPMM-UMR7554, ENSAM Metz, Arts et Métiers ParisTech, France

Summary

In this work, the finite element method is used to simulate a typical FLD test over tools of different radii. Parameters like the mesh density, element type, numerical determination of the onset of strain localization, limit strain definition etc. have been investigated. Finally, the limit strain for plane strain tension has been determined as a function of the thickness vs. tool radius (t/R) ratio. These simulations confirm that increasing the curvature of the tool increases the value of the limit strains. They also reveal that, as soon as bending becomes important, the practical relevance of the limit strains diminishes – at least with their current definition. The need for new strain localization models is emphasized, together with some of the associated challenges.

1. Introduction

Forming limits represent a key issue in sheet metal forming. The concept of forming limit diagram (FLD) has proved to be very useful in describing the forming limits of sheet metals in a general and practically relevant manner. Decades of effort have given rise to standardized experimental methods, as well as numerous modelling approaches, for the determination / prediction of the FLDs.

The development e.g. of high strength steels and the associated forming technologies revealed several limitations of the existing formability models. Among other limitations, FLDs were not aimed for application in parts with very small radii, but rather for the study of large panels in areas of reasonable curvature. The influence of curvature was already first pointed out in the early work of Gosh and Hecker [1]. In an attempt to extend the range of application of the FLD, Col [2,3] suggested the new concept of FLS – “Forming Limit Surface” (see Fig. 1). While its beneficial effect is largely recognised in the sheet forming press-shops, scarcely any data is available to support the speculations about the quantitative impact of the sheet/die curvature on the FLD. However, such information would be a prerequisite for the development of more realistic formability models and criteria.

This work is an attempt to quantitatively investigate the impact of curvature on the FLD. The analysis is restrained to the “FLD₀” point, corresponding to the plane strain mode. The finite element method is used to simulate typical FLD tests over dies of different radii. Parameters like the mesh density, element type, numerical determination of the onset of strain localization, limit strain definition etc. have been investigated. Finally, the limit strain for plane strain tension has been determined as a function of the thickness vs. die radius ratio.

2. Definition of the model problem

Due to its well known strain-path dependency, the forming limit diagram is formally determined for proportional (or linear) strain paths – while an infinite variety of non-linear strain-paths are often encountered in practice. Similarly, there is no unique manner to overlap bending to a typical (even linear) in-plane loading of a metal sheet. Obviously, the ratio of these two contributions and its history of application could have an important role on the limit strains. In this work, a particular choice is made that is inspired from the practice of the Nakajima FLD test: metal sheet is supposed clamped on its external contour and it is drawn over a punch with a circular profile. Since the plane strain loading mode is given particular attention, a two-dimensional, plane-strain configuration is considered (see Fig. 2).

Friction is neglected on both contact interfaces; in order to enforce localization on the top of the punch, the die radius is chosen slightly larger than the punch radius. The length of the sheet sample and the die radius have been tuned by means of numerical tests, so that their particular values do not affect the results.

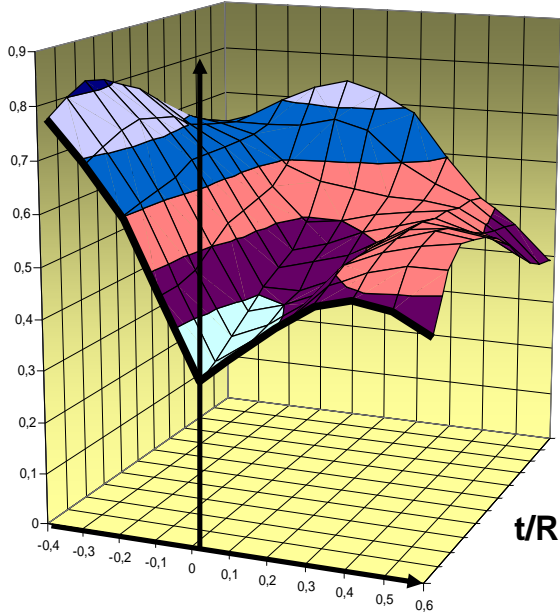

Fig. 1: Forming Limit Surface concept introduced by Col [2].

In order to address the effect of the thickness vs. punch radius ratio, three values have been tested for the punch radius: 50, 25 and 12.5 mm. They correspond to thickness vs. punch radius ratios of 0.06, 0.12 and 0.24. An arbitrary sheet thickness of 3 mm has been chosen but its particular value should not affect the results, provided that the above ratios are respected.

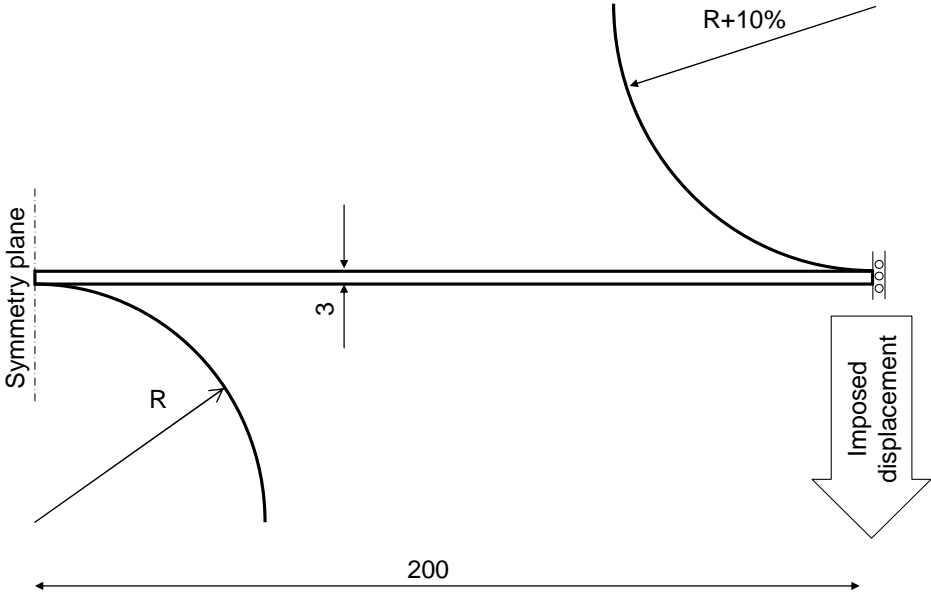

Fig. 2: Geometry and loading considered for the numerical simulations.

Solid finite elements are used for the simulations, in order to describe the strain heterogeneity in the pole region, due to bending and contact. Hybrid, displacement – pressure linear elements have been used with an enhanced strain definition aiming to accommodate incompatible modes due to bending. The simulations are performed with Abaqus/Standard. Fig. 3 gives an outline of the geometry and the finite element mesh. In the zone of interest, a number of ten finite elements in the thickness direction (twenty integration points) are used to correctly describe the strain gradient and to avoid mesh

dependency.

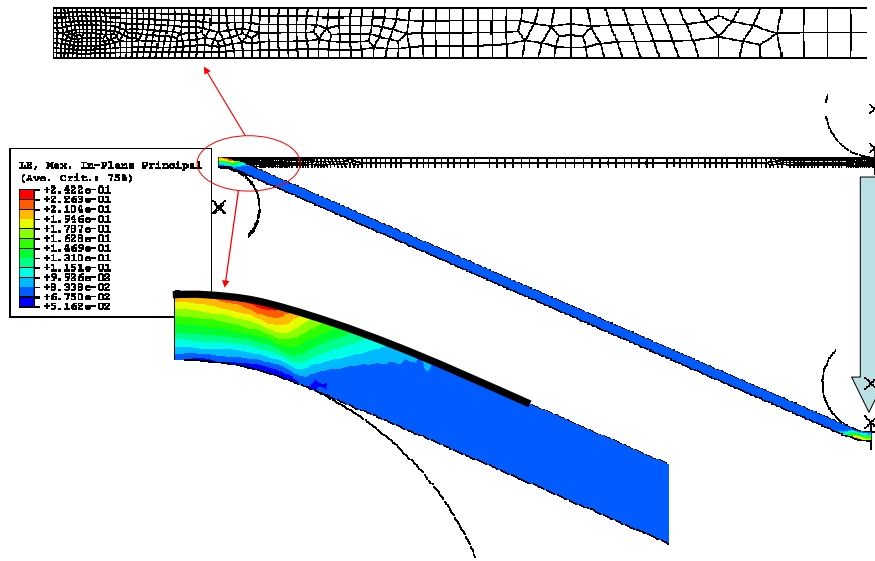

Fig. 3: Finite element mesh at the beginning of the simulation and sample results at the end of the simulation. Top: detail of the mesh at the pole region. Bottom: the in-plane major strain is measured on the top surface of the sheet, along the thick line, starting from the pole.

The strain analysis is made difficult by the presence of a strain gradient through the thickness of the sheet, due to bending. Since the experimental strain measurements are always made on the outer surface of the sheet, the same surface is conventionally used in the present analysis for the quantitative evaluation of strains. In fact, the principal in-plane strain is recorded on the outer surface of the sheet, starting from the pole – as indicated in Fig. 3. For large values of the punch radius, the strain value at the pole measured in this way should correspond to the so-called FLD_0 value – the lowest point of the FLD, laying on the vertical axis. The primary aim of this analysis is to quantify the evolution of this value when the punch radius is diminishing.

The material is considered isotropic (von Mises yield surface); the evolution of the flow stress Y (hardening) is described with a classical Voce law: $Y = \sigma_0 + Q_\infty(1 - e^{-b\bar{\epsilon}})$ with $\sigma_0 = 200$ MPa , $Q_\infty = 400$ MPa and $b = 10$. As already underlined, at the current stage the results are not to be directly related to an experimental situation – so the material has also been taken into account in this simplified manner.

3. Results of the FE simulations

Finite element simulations have been performed for the three values of punch radius. Among other quantities, the major strain has been recorded on the top surface of the sample. Fig. 4 shows a heterogeneous strain distribution corresponding to the zone affected by contact with the punch. Globally, the largest values of strain are observed in a small zone close to the pole – although the maximum is not necessarily located at the pole. The necking process becomes more and more catastrophic and eventually, strain localization occurs. However, this is not an instantaneous phenomenon and the definition of the exact moment of strain localization is not unique – as it is also the case experimentally. Moreover, the numerical results become less and less reliable as the strain localizes – due to pathological mesh sensitivity.

Fig. 4 illustrates the evolution of the strain distribution in the zone of interest at several moments in the loading history. The thick line designates a particular simulation increment, when most of the sheet is elastically unloaded suddenly, after what the plastic strain occurs only in small areas in the bent zones (this is especially true when only the outer surface of the sheet is analyzed). The strain

localization relevant for sheet metal forming is often considered to occur somewhat later. However, it is clear from Fig. 4 that the subsequent curves can hardly be used for quantitative strain evaluations. Indeed, the evolution of strains becomes strongly mesh dependent when most of the mesh is unloaded. On the other hand, damage should also be considered in the constitutive model if accurate limit strains are searched for at such large values of strain. In contrast, the numerical simulations with different mesh densities have shown almost identical strain distributions at the moment of global elastic unloading of the sample.

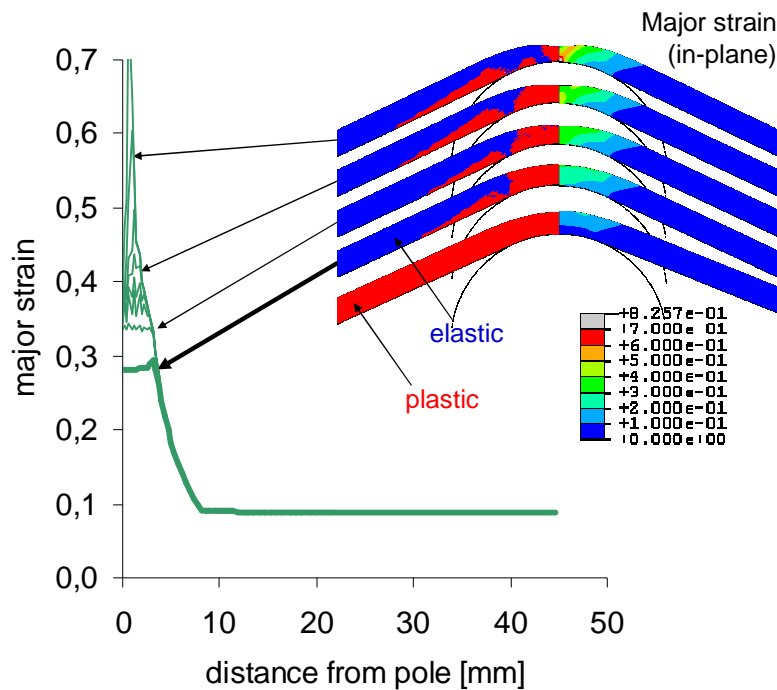

Fig. 4: Major strain distribution at different stages of the simulation; punch radius 12.5 mm.

According to these observations, the sudden elastic unloading of more than 80% of the sample is formally considered as the localization criterion in this study. Again, this criterion is not aimed to mimic the localization criterion adopted experimentally; it mainly allows a consistent quantitative comparison of the results for different punch radii. It is however expected that the trends of this criterion would correspond to the trends of more realistic localization criteria, in terms of t/R sensitivity – and remains representative for applications to sheet metal forming.

The same remarks about the strain distribution stand whatever the value of the die radius, as seen in Fig. 5. In order to compare the results to the ideal situation with no bending, a simple, tool-less tensile test (plane strain) has been simulated using the same initial mesh. The thick lines from all sub-figures in Fig. 5, corresponding to the strain distributions at localization, are overlapped in Fig. 6 (left). In the four cases, the strain distribution can be roughly described by two values: the value at the pole – the so-called FLD_0 value – and the value far from the pole, in the zone unaffected by bending. In real situations, this later zone is the largest one for many real parts.

The values of these two representative strains are summarized in Fig. 6 (right) for the different t/R ratios. Obviously, the two values are almost identical in the case of in-plane (tool-less) straining – due to the particular choice of the localization criterion considered here. When the t/R ratio is increasing, the FLD_0 strain is increasing, thus confirming the intuitive trend from Fig. 1. By contrast, the strain level far from the pole is decreasing with the t/R ratio.

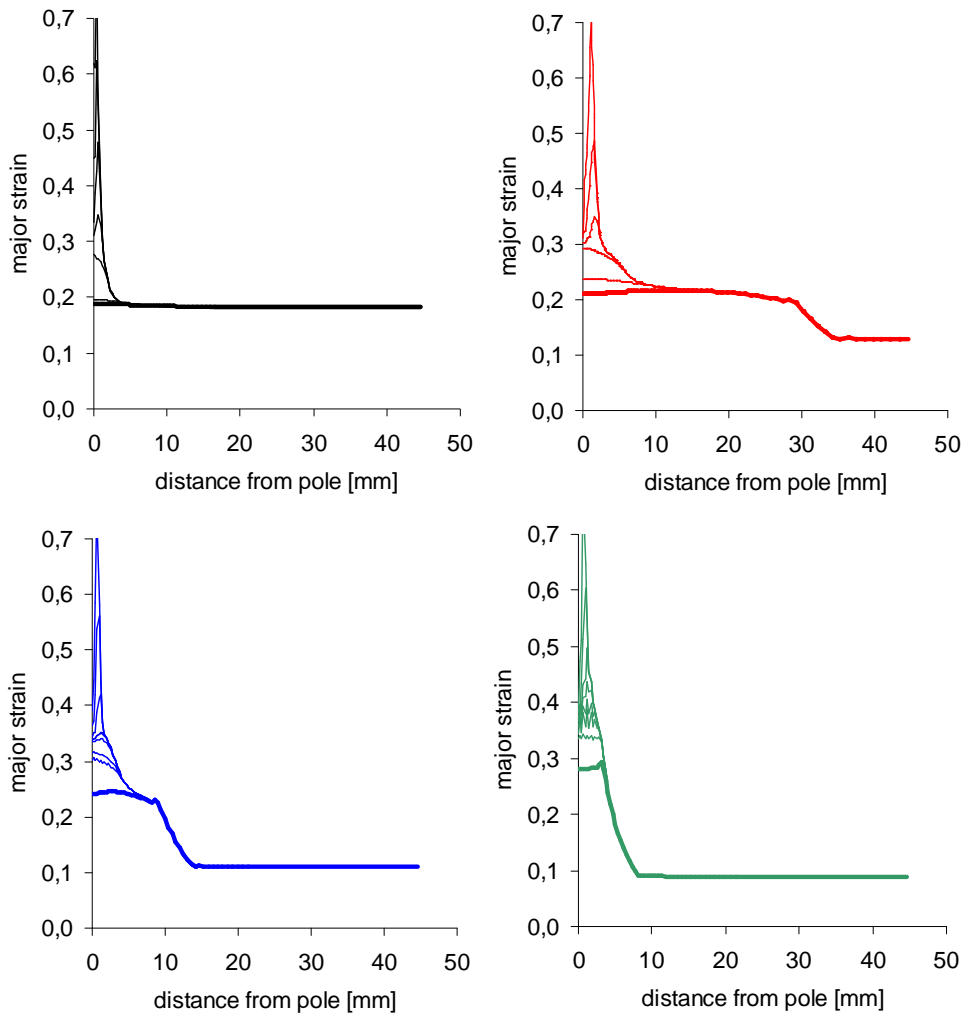

Fig. 5: Major strain distribution at different stages of the simulations, for different punch radii (from top left to bottom right: no radius; $R=50$ mm; $R=25$ mm; $R=12.5$ mm).

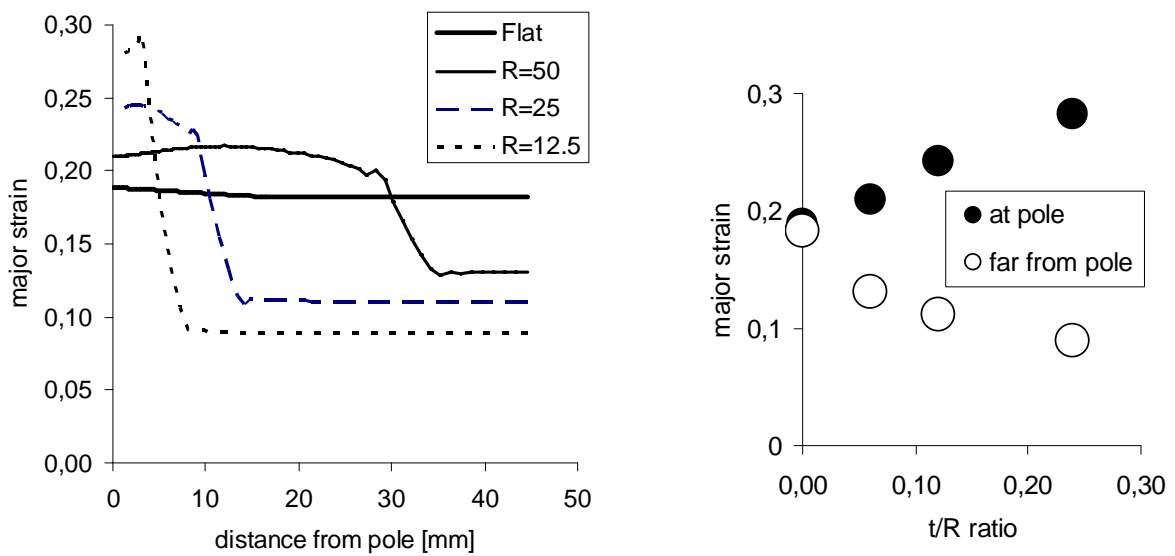

Fig. 6: Left: Major strain distributions at strain localization. Right: FLD_0 limit strain dependency to the t/R ratio.

4. Discussion and conclusions

Simple finite element simulations have shown that the impact of bending on the limit strains in plane strain loading can be quantified numerically. This effect is beneficial – strain localization is delayed by bending. However, the strains attained far from the pole are decreasing when the thickness vs. punch radius ratio t/R is increasing. Consequently, the limit strains have a very local meaning and are no longer characteristic of the overall straining of the sheet.

In order to relate the numerical results to experiments, one has to carefully adopt the localization criterion when limit strains are considered attained. The criterion adopted here was the sudden unloading of most of the sample; this choice prevents a too important sensitivity of the results to mesh density. On the other side, this criterion is easy to adopt in finite element simulations – while it would be more difficult to apply for experiments.

The current analysis has several limitations. First of all, the results depend at some extent on the mesh. The mesh density has been tuned by numerical tests to avoid such dependency – however it is far too dense to be used in real stamping applications. Eventually, the limit strains at the pole (on the outer surface of the sheet) have less practical relevance when bending becomes important: they give no information about the underlying strains through the thickness of the sheet – and they are also not representative of the strains beyond the tool radius.

The prediction of strain localization appeals for new localization criteria and models, taking into account the curvature of the sheet. However, few or no localization criteria currently in use allow a straightforward extension to heterogeneous strain fields. Moreover, one can expect that when the strains are increasing, damage should not be neglected in the material modelling. Finally, the mesh dependency remains a major difficulty that must be taken into consideration.

Numerical simulations like the ones performed in this analysis can bring insight about the required features of such new models – and could provide a means of validation. In future work, these simulations will be extended to other straining modes (uniaxial tension, balanced biaxial tension etc.) in an attempt to simulate the forming limit surface (Fig. 1). This purely numerical study will be accompanied by a modelling effort to take curvature into account in strain localization.

References

- [1] Gosh, A.K., Hecker, S.S.: ***; Met. Trans. 5, 1974, 2161-2164.
- [2] Col, A.: FLCs: Past, present and future. Proceeding of IDDRG 2002, Nagoya, Japan.
- [3] Col, A.: FLCs: are we at a turn? Proceedings of IDDRG 2005, Besançon, France.