



### Science Arts & Métiers (SAM)

is an open access repository that collects the work of Arts et Métiers Institute of Technology researchers and makes it freely available over the web where possible.

This is an author-deposited version published in: <https://sam.ensam.eu>  
Handle ID: <http://hdl.handle.net/10985/15788>

#### To cite this version :

Nolwenn FOUGERON, Xavier BONNET, Jean-Loïc ROSE, Pierre-Yves ROHAN, Hélène PILLET  
- In vivo identification of the mechanical properties of thigh tissues from FreeHand Ultrasound for the numerical investigation of loads at the socket/residual limb interface of amputee people - 2019

Any correspondence concerning this service should be sent to the repository

Administrator : [archiveouverte@ensam.eu](mailto:archiveouverte@ensam.eu)



## In vivo identification of the mechanical properties of thigh tissues from FreeHand Ultrasound for the numerical investigation of loads at the socket/residual limb interface of amputee people

N. Fougeron<sup>1,2</sup>, X Bonnet<sup>1</sup>, J-L Rose<sup>2</sup> P-Y Rohan<sup>1</sup>, H. Pillet<sup>1</sup>,

1 : Institut de Biomécanique Humaine Georges Charpak, Arts et Métiers ParisTech, 151 boulevard de l'Hôpital, 75013 Paris, France

2 : Proteor, Recherche et développement, 5 boulevard Winston Churchill, 21000 Dijon, France

**Abstract:** Prosthetic sockets are custom-designed and are decisive for functionality and comfort of limb prosthesis. To ensure load transmission and stability, high interface stresses are applied. Several computer models of the socket/residual limb assembly have been designed to identify critical stress accumulations that may induce discomfort or trauma. However, clinically relevant personalized Finite Element (FE) models represent a bottleneck. While material definition of tissues is critical for the evaluation of socket/tissues interactions, personalization of deep Soft Tissue (ST) material properties remains challenging. For clinical purpose, it has to be simple, in vivo and thus non-invasive. This work explores the feasibility of freehand ultrasound with an inverse method for assessing mechanical properties of the ST of the thigh. To be relevant for socket design, the residual strain from donning socket was simulated by compressing tissues (5% of initial circumference).

Force-displacement curves acquired during localized compressions of the anterior thigh of one non-amputee subject was measured with a custom-made set-up combining freehand ultrasound and a force sensor (fig 1A). Two configurations were investigated, for which three acquisitions of ten loading/unloading cycles were acquired. From the ultrasound images, an idealized geometry of the thigh was designed. A FE model was designed to model the response of tissues in large displacement (>20 mm) with Ogden constitutive model (fig 1B). Material parameters were calibrated against mean experimental data for each configuration. A membrane was added in the compressed model.

Experimental and simulation curves of both configurations are provided below (fig 1C). The optimized shear modulus are 1.3 and 7.4 kPa, with RMSE of 2.4 and 3.2, for configurations 1 and 2, respectively.

A simple non-invasive method to identify the in vivo mechanical properties from FreeHand Ultrasound was developed. Results are only presented for one of the six subjects that will participate to the study, but preliminary results are encouraging. In fact, although being freehand, the proposed method allows fitting simulations to experimental data. Moreover, resulting shear modulus are consistent with literature [1]. To authors' knowledge, this is the first attempt to compare uncompressed and compressed tissues in vivo material properties, in order to consider the compressed state of ST in sockets. Configurations in large deformation allow capturing the response of tissues in domains compatible with the use of prosthesis. These results contrast with previous studies where methods were cumbersome and/or not sufficient to assess the mechanical properties of ST.

**Figure Caption:** A) Studied configurations: relaxed and uncompressed versus relaxed and B) FE simulation C) mean experimental results (continuous lines) and simulation curves (dotted lines). Green: compressed, red: uncompressed.

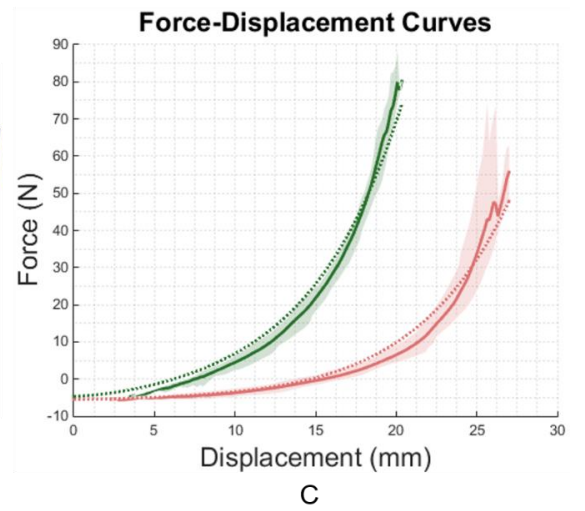
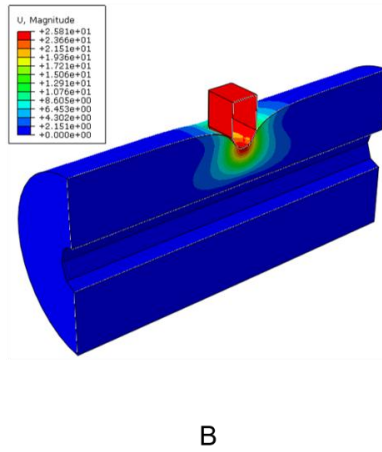
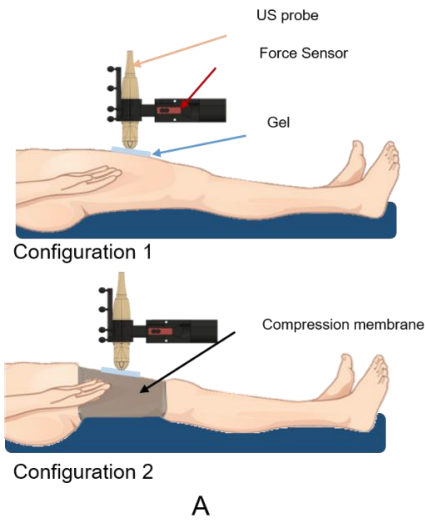

**References:**

G. Dubois *et al.*, "Reliable Protocol for Shear Wave Elastography of Lower Limb Muscles at Rest and During Passive Stretching," *Ultrasound Med. Biol.*, 41(9), 2284–2291, 2015.