



### **Science Arts & Métiers (SAM)**

is an open access repository that collects the work of Arts et Métiers Institute of Technology researchers and makes it freely available over the web where possible.

This is an author-deposited version published in: <https://sam.ensam.eu>  
Handle ID: <http://hdl.handle.net/10985/21898>

#### **To cite this version :**

Thomas DAMAY, Frederic HAUVILLE - Cycloidal Dynamic Propulsion or Positioning System For a Ship. 2022-03-03. Brevet n° US2022/0063783A1

Any correspondence concerning this service should be sent to the repository

Administrator : [scienceouverte@ensam.eu](mailto:scienceouverte@ensam.eu)





(19) **United States**

(12) **Patent Application Publication**  
**DAMAY et al.**

(10) **Pub. No.: US 2022/0063783 A1**

(43) **Pub. Date: Mar. 3, 2022**

(54) **CYCLOIDAL DYNAMIC PROPULSION OR POSITIONING SYSTEM FOR A SHIP**

**Publication Classification**

(71) Applicant: **ECOLE NATIONALE SUPERIEURE D'ARTS ET METIERS, Paris (FR)**

(51) **Int. Cl.**  
**B63H 1/10** (2006.01)

(72) Inventors: **Thomas DAMAY, Crozon (FR); Frédéric HAUVILLE, Crozon (FR); Jacques-André ASTOLFI, Crozon (FR)**

(52) **U.S. Cl.**  
CPC ..... **B63H 1/10** (2013.01); **B63H 2001/105** (2013.01)

(73) Assignee: **ECOLE NATIONALE SUPERIEURE D'ARTS ET METIERS, Paris (FR)**

(57) **ABSTRACT**

(21) Appl. No.: **17/414,894**

(22) PCT Filed: **Dec. 13, 2019**

(86) PCT No.: **PCT/EP2019/085163**

§ 371 (c)(1),

(2) Date: **Jun. 16, 2021**

A cycloidal dynamic propulsion or positioning system for a ship in water that exhibits a direction of flow, including a frame, a rotor mounted to be movable in rotation on the frame about a main axis at right angles to the flow, including a plurality of arms extending radially with respect to the main axis, a main motor equipped with a rotary coder and driving the rotor in rotation, for each arm, a blade mounted to be movable in rotation on the arm about a secondary axis parallel to the main, for each blade, a secondary motor equipped with a rotary coder and driving the blade in rotation, for at least one blade, a load sensor able to evaluate the loads exerted on the blade, and a control unit connected to each coder, strain sensor and motor and controlling the rotation of each motor in terms of angle and speed.

(30) **Foreign Application Priority Data**

Dec. 19, 2018 (FR) ..... FR1873269

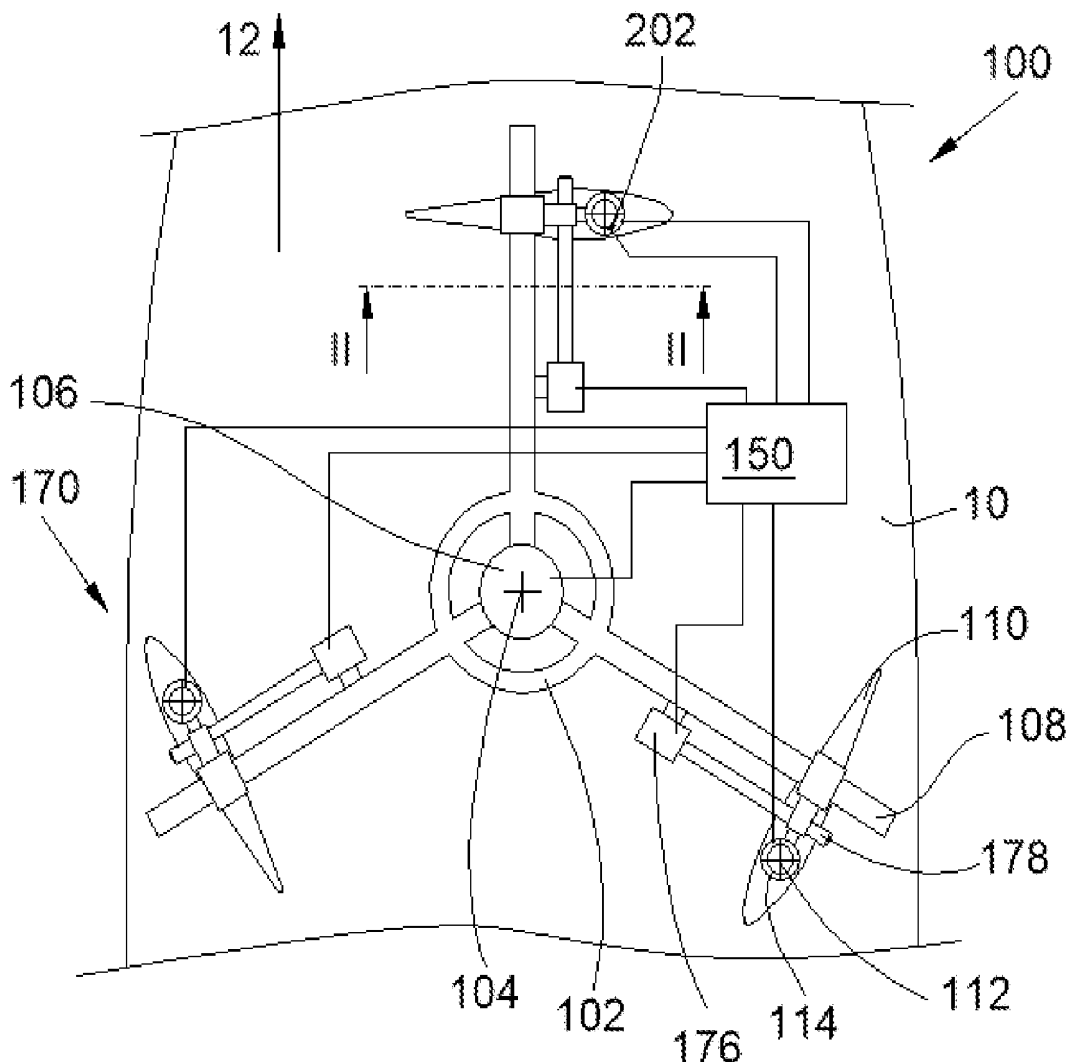

[Fig. 1]

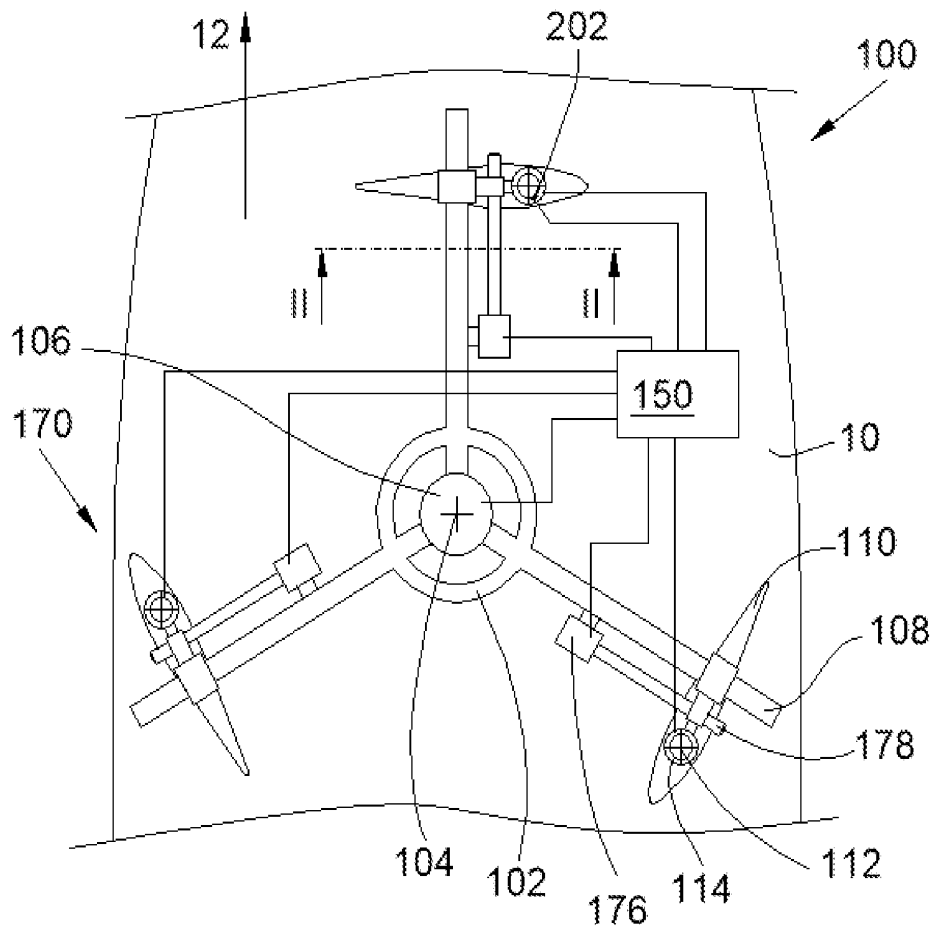

[Fig. 2]

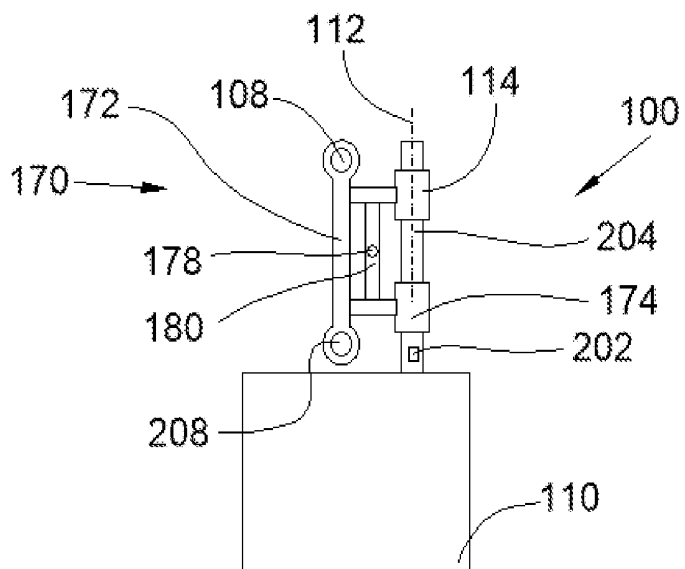

## CYCLOIDAL DYNAMIC PROPULSION OR POSITIONING SYSTEM FOR A SHIP

### TECHNICAL FIELD

[0001] The present invention relates to a cycloidal dynamic propulsion or positioning system for a ship, and a ship comprising at least one such cycloidal dynamic propulsion or positioning system.

### STATE OF THE ART

[0002] A propulsion system of Voith-Schneider type is disposed under the hull of a ship, and it comprises a rotor with vertical axis which is driven in rotation about a main axis by a motor, and a plurality of vertical blades in which each is mounted to be movable on the rotor at a distance from the main axis.

[0003] Each blade is movable in rotation about a secondary axis, also vertical.

[0004] The propulsion system also comprises a mechanical system, generally consisting of connecting rods, which is configured to displace each blade as a function of the degree of rotation of the rotor. The displacement of each blade is cyclic and, based on the position of the rotor, each blade takes a particular position that it returns to on each revolution.

[0005] Also known is the document US-A-2015/321740 which discloses a propulsion system with vertical blades and a control unit which controls the propulsion system using different position sensors which are linked to the blades. However, none of these sensors is a load sensor which informs on the loads undergone by at least one blade.

[0006] Although such a propulsion system gives satisfactory results, it is desirable to find a propulsion system which allows a greater freedom in the position of the blades.

### SUMMARY OF THE INVENTION

[0007] One object of the present invention is to propose a cycloidal dynamic propulsion or positioning system which comprises means for displacing the blades independently of one another based on the loads undergone by at least one blade.

[0008] To this end, a cycloidal dynamic propulsion or positioning system is proposed for a ship sitting in water that exhibits a direction of flow, said cycloidal dynamic propulsion or positioning system comprising:

[0009] a frame,

[0010] a rotor mounted to be movable in rotation on the frame about a main axis at right angles to the direction of flow, and comprising a plurality of arms extending radially with respect to the main axis,

[0011] a main motor equipped with a rotary coder and driving said rotor in rotation,

[0012] for each arm, a blade mounted to be movable in rotation on the arm about a secondary axis parallel to the main axis,

[0013] for each blade, a secondary motor equipped with a rotary coder and driving said blade in rotation,

[0014] for at least one blade, a load sensor arranged to be able to evaluate the loads which are exerted on the blade, and

[0015] a control unit connected to each rotary coder, to the load sensor and to each motor and controlling the rotation of each motor in terms of both angle and speed.

[0016] Such a cycloidal dynamic propulsion or positioning system makes it possible to adjust the position of each blade as a function of the data collected by the load sensor and thus optimize the efficiency of the propulsion system.

[0017] Advantageously, the load sensor is disposed on a shaft between the secondary motor and the blade.

[0018] Advantageously, the cycloidal dynamic propulsion or positioning system comprises a displacement system controlled by the control unit and intended to displace the blade and the associated secondary motor along the arm.

[0019] Advantageously, the main motor operates as an electrical generator.

[0020] Advantageously, the displacement system comprises:

[0021] for each arm, an additional arm fixed to the rotor parallel to said arm,

[0022] a runner secured to the secondary motor, and mounted to slide on the arm and the additional arm,

[0023] a drive system which is connected and controlled by the control unit to displace the runner along the arms.

[0024] The invention also proposes a ship comprising a hull and a cycloidal dynamic propulsion or positioning system according to one of the preceding variants in which the frame is fixed to the hull and in which at least the blades are outside the hull.

### BRIEF DESCRIPTION OF THE DRAWINGS

[0025] The features of the invention mentioned above, and others, will become more clearly apparent on reading the following description of an exemplary embodiment, said description being given in relation to the attached drawings, in which:

[0026] FIG. 1 is a top view of a cycloidal dynamic propulsion or positioning system according to the invention, and

[0027] FIG. 2 is a view in cross section along the line II-II of the cycloidal dynamic propulsion or positioning system of FIG. 1.

### DETAILED DESCRIPTION OF EMBODIMENTS

[0028] In the following description, the terms relating to a position are taken with reference to a propulsion system of the Voith-Schneider type in position of use under the hull of a ship.

[0029] FIG. 1 shows a ship represented by a part of its hull 10. The ship sits in water. The ship can be a ship having a direction of advance 12 parallel to the axis of the ship and navigating on the surface or underwater. The ship can also be a ship which seeks to maintain its position in currents, such as a platform for example. In one case as in the other, the ship sits in water which exhibits a direction of flow with respect to the ship which is due to the speed of the ship or to the water current. In the case of a ship with a direction of advance 12, the direction of flow is the reverse of the direction of advance 12.

[0030] The ship is equipped, under its hull 10, with a cycloidal dynamic propulsion or positioning system 100 which comprises a frame fixed to the hull 10, a rotor 102 mounted to be movable in rotation on the frame about a main axis 104 which is at right angles to the direction of flow. The main axis 104 is thus transversal with respect to the direction of flow.

[0031] Thus, for a ship on the surface, the main axis **104** is vertical or with a small angle with respect to the vertical. For a ship underwater, the main axis **104** can take another orientation in a plane at right angles to the direction of flow. Thus, in the case of an underwater ship, there could be three cycloidal dynamic propulsion or positioning systems **100** angularly distributed at  $120^\circ$  from one another in a plane at right angles to the direction of flow.

[0032] FIG. 2 shows a part of the cycloidal dynamic propulsion or positioning system **100**. Depending on the case, the cycloidal dynamic propulsion or positioning system **100** makes it possible to advance the ship or to hold it in its position.

[0033] The rotor **102** is driven in rotation by a main motor **106** equipped with a rotary coder that makes it possible to know the angular position of the main motor **106**.

[0034] The rotor **102** is equipped with a plurality of arms **108**, here three of them. Each arm extends radially with respect to the main axis **104**.

[0035] Each arm **108** bears a blade **110** which is mounted to be movable in rotation on the arm **108** about a secondary axis **112** parallel to the main axis **104**, that is to say, here, vertical. The secondary axes **112** and the main axis **104** do not coincide, that is to say that each secondary axis **112** is at a distance from the main axis **104**. The blades **110** are situated outside of the hull **10**, and in particular under the hull **10**.

[0036] Each blade **110** is driven in rotation by a secondary motor **114** equipped with a rotary coder that makes it possible to know the angular position of the secondary motor **114**.

[0037] The cycloidal dynamic propulsion or positioning system **100** also comprises a control unit **150** which receives information from the rotary coders and controls the rotation of each motor **106**, **114** in terms of both angle and speed.

[0038] In order to allow the interaction between the water and the blades **110**, at least the blades **110** are outside the hull **10**. Depending on the layout of the cycloidal dynamic propulsion or positioning system **100**, other elements may be entirely or partially in the water or in a fairing above the water.

[0039] The control unit **150** comprises, conventionally linked by a communication bus: a processor or CPU (Central Processing Unit); a random access memory RAM; a read only memory ROM; a storage unit such as a hard disk or a storage medium reader; at least one communication interface, allowing the control unit **150** to communicate with the rotary coders, the motors **106**, **114** and at least one load sensor **202** as is explained below.

[0040] The processor is capable of executing instructions loaded into the RAM from the ROM, from an external memory (not represented), from a storage medium (such as an SD card), or from a communication network. When the cycloidal dynamic propulsion or positioning system **100** is powered up, the processor is capable of reading instructions from the RAM and of executing them. These instructions form a computer program causing the implementation, by the processor, of all or part of the algorithms and steps described hereinbelow.

[0041] All or part of the algorithms and steps described hereinbelow can be implemented in software form by the execution of a set of instructions by a programmable machine, for example a DSP (Digital Signal Processor) or a microcontroller, or be implemented in hardware form by a

machine or a dedicated component, for example an FPGA (Field-Programmable Gate Array) or an ASIC (Application-Specific Integrated Circuit).

[0042] Thus, the control unit **150** can control the position of each blade **110** independently of one another as a function of the position of the rotor **102** informed by the rotary coder of the main motor **106** and more simply than with the use of a mechanical system. Based on the position of the rotor **102**, each blade **110** takes a particular position which therefore varies with the rotation of the rotor **102**.

[0043] Furthermore, it is possible to switch from epicycloidal operation to trochoidal operation simply and rapidly.

[0044] The cycloidal dynamic propulsion or positioning system **100** also comprises, for at least one blade **110**, a load sensor **202** connected to the control unit **150**. The load sensor **202** is arranged so as to be able to evaluate the loads which are exerted on the blade **110**. In the embodiment of the invention presented in FIG. 2, the load sensor **202** is disposed on the shaft **204** in the secondary motor **114** and the blade **110**. The shaft **204** is, here, the motor shaft of the secondary motor **114** and the blade **110** is fixed to this shaft **204**.

[0045] In the present case, the load sensor **202** measures the loads undergone by the shaft **204** which are representative of the loads being exerted on the blade **110** and that the blade **110** therefore undergoes because of the water, in particular the tensile and/or compressive and/or flexural loads undergone by the blade **110**.

[0046] According to a particular embodiment, the load sensor **202** is a sensor which comprises at least one strain gauge and, according to a particular embodiment, the sensor is based on strain gauges mounted in Wheatstone bridge configuration, that is to say that there are at least four gauges mounted in Wheatstone bridge configuration, but there can be several Wheatstone bridges, i.e. as many times four gauges. Obviously, any other technology can be envisaged, such as a piezo sensor for example.

[0047] A load sensor **202** called "balance" is for example used (here, a balance with two components), allowing access to the loads normal and tangential to the blade **110** independently of the point of application of the load.

[0048] Internally, this load sensor **202** comprises several strain gauge bridges which measure the displacements (very small, of a few tens of micrometers) due to the hydrodynamic loading, and a specific matrix computation involving these measurements, makes it possible to work out the loads required. A prior calibration of the balance allows the matrix used to be constructed. The calibration is done out of water and it consists in measuring the outputs of the gauge bridges for loads that are known and imposed at different points of the blade **110**.

[0049] Only a single load sensor **202** need be put in place, because the deformations of each blade **110** are considered to be identical for an angular position of the rotor **102** and an angular position of the blade **110**. Obviously, it is possible to have one load sensor **202** for each blade **110**.

[0050] Thus, from the data recorded by the load sensor **202**, the control unit **150** manages the speed of rotation of the rotor **102** and the position of each blade **110** as a function of the angular position of the rotor **102**. For example, each blade **110** can be positioned so as to maximize the loads in the direction of advance of the ship.

[0051] The pitch of the blades **110** can therefore be adapted according to the speed of rotation of the rotor **102**

and as a function of data from the load sensor 202. Thus, the detection of strong load variations on the blade 110 can be the sign of a slippage of the boundary layer around this blade 110, and it is then possible to modify the position of the blades 110 in order to avoid this slippage at each angular position of the rotor 102.

[0052] In the embodiment of the invention presented in FIGS. 1 and 2, each blade 110 is movable in translation along the associated arm 108 in order to modify the center distance between the main axis 104 and the secondary axis 112.

[0053] This embodiment is particularly advantageous when the main motor 106 can operate as an electrical generator. The change of center distance of the blades 110 makes it possible to extend the center distance and thus, when the water current makes the blades 110 revolve about the main axis 104, the main motor 106 operating as an electrical generator generates an electrical current to deliver electricity to the ship or to storage batteries.

[0054] To this end, the cycloidal dynamic propulsion or positioning system 100 comprises, for each blade 110, a displacement system 170 which is a motorized slide system which is controlled by the control unit 150 and arranged to displace the blade 110 and the associated secondary motor 114 along the arm 108.

[0055] In the embodiment of the invention presented here, the displacement system 170 comprises, for each arm 108, an additional arm 208 fixed to the rotor 102 parallel to said arm 108 and disposed here under said arm 108.

[0056] The displacement system 170 also comprises a runner 172 mounted to slide on the arm 108 and the additional arm 208.

[0057] The runner 172 is secured to the secondary motor 114.

[0058] In the embodiment of the invention presented in FIG. 2, the runner 172 is also secured to a bearing 174 in which the shaft 204 is mounted.

[0059] The displacement system 170 comprises a drive system which is connected and controlled by the control unit 150 to displace the runner 172 along the arms 108 and 208.

[0060] The drive system can for example be a cylinder, for example hydraulic.

[0061] The drive system here comprises a displacement motor 176 bearing a threaded rod 178 meshing with a nut 180 of the runner 172 so as to form a worm screw system in which the rotation of the threaded rod 178 in one direction will displace the runner 172 and therefore the blade 110 in one direction and in which the rotation of the threaded rod 178 in the opposite direction will displace the runner 172 and therefore the blade 110 in an opposite direction.

[0062] The displacement motor 176 is connected and controlled by the control unit 150.

1. A cycloidal dynamic propulsion or positioning system for a ship sitting in water that exhibits a direction of flow, said cycloidal dynamic propulsion or positioning system comprising:

a frame,

a rotor mounted to be movable in rotation on the frame about a main axis at right angles to the direction of flow, and comprising a plurality of arms extending radially with respect to the main axis,

a main motor equipped with a rotary coder and driving said rotor in rotation,

for each arm, a blade mounted to be movable in rotation on the arm about a secondary axis parallel to the main axis,

for each blade, a secondary motor equipped with a rotary coder and driving said blade in rotation,

for at least one blade, a load sensor arranged to be able to evaluate the loads which are exerted on the blade, and a control unit connected to each rotary coder, to the load sensor and to each motor and controlling the rotation of each motor in terms of both angle and speed.

2. The cycloidal dynamic propulsion or positioning system as claimed in claim 1, wherein the load sensor is disposed on a shaft between the secondary motor and the blade.

3. The cycloidal dynamic propulsion or positioning system as claimed in claim 1, wherein it comprises a displacement system controlled by the control unit and intended to displace the blade and the associated secondary motor along the arm.

4. The cycloidal dynamic propulsion or positioning system as claimed in claim 3, wherein the main motor operates as an electrical generator.

5. The cycloidal dynamic propulsion or positioning system as claimed in claim 3, wherein the displacement system comprises:

for each arm, an additional arm fixed to the rotor parallel to said arm,

a runner secured to the secondary motor, and mounted to slide on the arm (108) and the additional arm,

a drive system which is connected and controlled by the control unit to displace the runner along the arms.

6. A ship comprising a huller and a cycloidal dynamic propulsion or positioning system as claimed in claim 1, in which the frame is fixed to the hull and in which at least the blades are outside the hull.

\* \* \* \* \*