



Science Arts & Métiers (SAM)

is an open access repository that collects the work of Arts et Métiers Institute of Technology researchers and makes it freely available over the web where possible.

This is an author-deposited version published in: <https://sam.ensam.eu>
Handle ID: <http://hdl.handle.net/10985/22226>

To cite this version :

Tobias EIFLER, Jean-Yves DANTAN - Integrated uncertainty management in parametric design and tolerancing - Journal of Engineering Design - Vol. 32, n°10, p.517-537 - 2021

Any correspondence concerning this service should be sent to the repository

Administrator : scienceouverte@ensam.eu



Integrated uncertainty management in parametric design and tolerancing

Jean-Yves Dantan ^a and Tobias Eifler ^b

^aLCFC, Arts et Métiers, Université de Lorraine, Metz, France; ^bTechnical University of Denmark (DTU), Kgs. Lyngby, Denmark

ABSTRACT

The key purpose of robust design and tolerancing approaches is the management of uncertainty. Against this background, it is not surprising that there is a large overlap between the basic ideas and concepts in both fields. However, while sharing the same objective, the focus of the corresponding development phases is quite different; that is (i) the determination of solutions that react insensitive, in other words robust, to noise factors – *Robust parametric design*; and (ii) the limitation of the effects of manufacturing imprecision by the specification of optimal tolerances – *Tolerancing*. As a consequence, there also is a significant gap between both concepts. Focusing on the improvement of design solutions, robustness is often related to uncertainty of not known designs or manufacturing processes. Due to the complexity of a largely matured solution, tolerancing tasks are usually based on previously specified, key characteristics or behavior models that are supposed perfect. Therefore, an overview of robust design and tolerancing is used to highlight the deficiencies, and to formalize a new classification of tolerance analysis issues based on the type of uncertainty considered. The proposed framework is based on Dempster-Shafer evidence theory and allows to efficiently perform statistical tolerance analyses under model imprecision.

KEYWORDS

Robust design; tolerancing; uncertainty management; uncertainty propagation

1. Introduction

Uncertainty is ubiquitous in engineering design, as a design team usually faces the challenge of accurately predicting the behavior and identifying design parameters of the designed systems. This challenge results from different aspects, including the nature of design as gradual development of solutions, the ever-increasing complexity of products, lack of knowledge about the environment, manufacturing imprecision, etc., and is frequently discussed as ‘uncertainty’ in design (Dantan et al. 2013; Malmiry et al. 2016). For the overall development process, these uncertainties lead to risks (Morse et al. 2018) including **performance risk** (due to uncertainty about desired quality criteria), **schedule** and **development cost risk** (due to uncertainty about lead time and costs), **technology risk** (due to uncertainty about realizable performance benefits), as well as **market risk** (due to uncertainty of market acceptance).

CONTACT Jean-Yves Dantan  jean-yves.dantan@ensam.eu

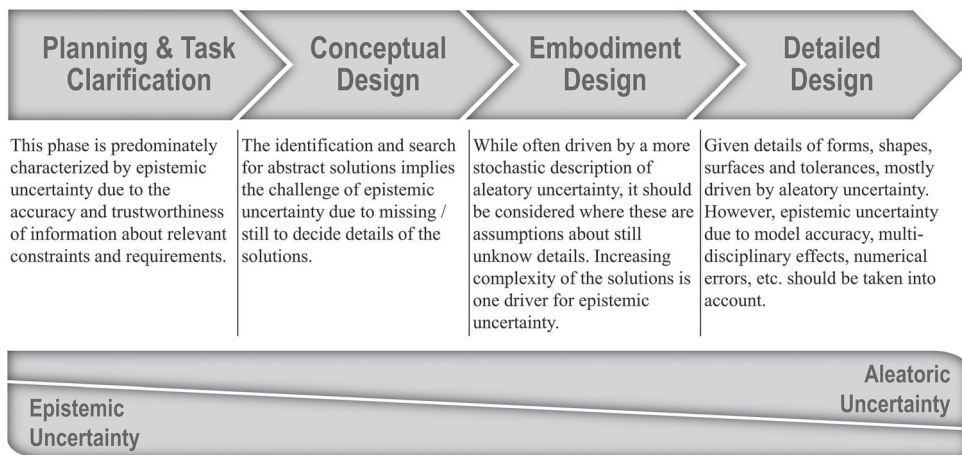

Figure 1. Uncertainty in Development.

Given that uncertainty is an unavoidable reality of engineering design, a coherent framework for managing the different types of uncertainty is consequently of utmost importance for a successful development process. There are various classifications of uncertainties in literature (Thunnissen 2003; Wang et al. 2019), classically distinguishing between **Aleatory uncertainty**, describing the inherent randomness of a phenomenon; and **Epistemic uncertainty** due to a lack of knowledge. As exemplified in Figure 1 with a generic design process (Pahl et al. 2007), these different types of uncertainty exist in all stages of the design process, and should be identified and managed accordingly.

In light of the above, a significant amount of research has been devoted to the uncertainty management during the design process. One aspect of particular interest is hereby Taguchi's concept of off-line quality. As a pioneer in this field, Taguchi (1987) suggests a three-stage process: **system design**, **parameter design**, and **tolerance design**.

System Design is the conceptualization and synthesis of a product. During this stage, the design team determines the new concepts, the right combination of structure/configuration of the product that will satisfy functional and economical specifications.

In the **Parameter Design** phase, the system variables are experimentally or numerically analyzed to determine how the product behaves to 'noise' in the system. Parameter design is related to finding the appropriate design factor levels to make the system less sensitive to uncertainty and variation in noise factors, i.e. to make the system behavior more robust.

The final step is **Tolerance Design**, that is a set of activities to allocate suitable tolerance levels around the optimized parameter settings based on the available manufacturing processes.

While seemingly offering a comprehensive approach that roughly follows the generic development phases above, most authors agree that the *Parameter Design* phase is the main thrust of Taguchi's approach (Jugulum and Frey 2007). This implies a relatively narrow focus on one single, even though important, task in embodiment design, which is the efficient optimization of parameter settings for a previously defined product configuration. As the considered parameter settings also provide the basis for the allocation of tolerances in the final *Tolerance Design* step, the approach furthermore excludes numerous other related *Tolerancing* considerations such as geometric tolerances, tolerance specifications, etc.

This research seeks to analyze the practices of uncertainty management during parameter design, in order to investigate which concepts can be adopted to bridge the currently existing gap towards all subsequent tolerancing activities. On this basis, a newly proposed tolerancing framework integrates the assessment of the impact of several uncertainties (model imprecision, model parameter uncertainty) on the accuracy of the tolerance analysis (one of the most important step of the Tolerance design).

The remainder of the paper is structured as follows: section 2 reviews existing work in the field of Robust Parameter Design, focusing on the corresponding strategies for uncertainty management. The analysis of these practices allows to identify: which uncertainties are considered? And how? On this basis, section 3 presents a critical analysis of tolerancing practices. In order to address the identified white spots in available frameworks, section 4 then proposes a new/extended framework and the corresponding techniques to manage model uncertainty and model parameter imprecision during the tolerance analysis phase.

2. Robust design – parameter design and uncertainty management

The basic ideas and principles of Robust Design (RD) originate from Genichi Taguchi's work in the late 1950s and focus on improving quality by ensuring the '*insensitivity of products and processes against different sources of variation*' without eliminating the sources of variation themselves (Taguchi 1987). RD consequently aims at designing products that show a consistently high quality and performance despite noise factors, including production variation in form of tolerances, not (fully) specified load scenarios and unexpected stress levels, ambient conditions of use such as temperature or humidity, as well as varying degradation effects. And given the fact that the uncertainty of corresponding variation influences in the lifecycle were, and still are, widely accommodated by quality control measures and safety factors, RD also allows for significant cost reductions (Ebro and Howard 2016).

2.1. Basic concepts and fundamental classification

As already laid out above, Taguchi's fundamental Quality Engineering framework suggest three different phases of a RD process, that is (1) *System Design*, (2) *Parameter Design*, and (3) *Tolerance Design*. And while research on RD has developed into a variety of different research areas over time¹, Taguchi's work on phase (2), the optimization of a given solution by means of suitable experimentation strategies and the corresponding statistical analyses, has received most of the attention by academics and practitioners (Jugulum and Frey 2007). Best illustrated by the P diagram in Figure 2, *Parameter Design* advocates the use of crossed-array experiments as well as Signal to Noise ratios (SNR) for an efficient assessment of interactions between control and uncertain noise factors. In other words, the possibility of increasing the product's robustness by deliberately choosing suitable parameter combinations for a set of control factors that reduce the effect of potential variation of the non-controllable noise factors.

- Signal factors (M) are the parameters set by the user or operator of the product to express the target value for the response of the product.

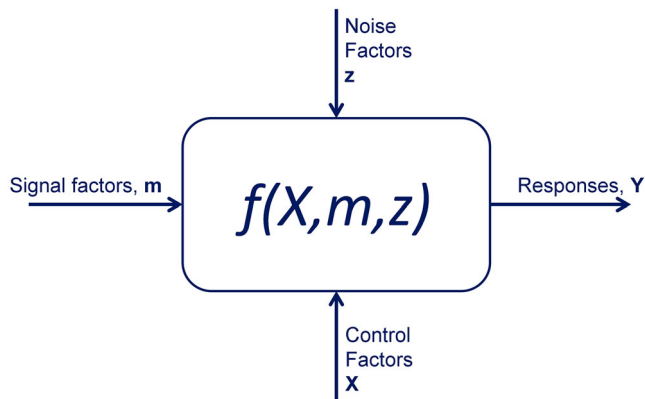

Figure 2. P_Diagram.

- Noise factors (Z) are the potential sources of variation and cannot be controlled by the designer.
- Control factors (X) are those parameters that can be specified freely by the designer.

In the following, the current practices for treating uncertainty in the context of Taguchi's *Parameter Design* phase are reviewed in order to provide a coherent basis for establishing a corresponding tolerancing framework. The review is referring to the first three categories of the fundamental classification suggested by Choi (2005), see Figure 3. The framework distinguishes four types of RD tasks according to the level of uncertainty of the conducted analysis. While providing an understanding which types of uncertainty are relevant for achieving robustness, the framework consequently also implies that it is usually neither useful, nor desired to perform all types of analyses. For the choice of suitable approaches, it should instead be well understood, in which of the categories below a development project operates in. Examples are the typical parametric exploration of solutions in virtual or physical experiments (Type I), the optimization towards a robust control factor range based on an available, sufficiently accurate analytical description (Type II), or the structuring decisions along an hierarchical design process (Type IV) that usually goes across different groups, department, and engineering disciplines.

- In **Type I robust design**, design variable values are identified to satisfy a set of performance requirement targets regardless of noise factors. Noise factors are not under a designer's control.
- In **Type II robust design**, design variable values are determined that satisfy a set of performance requirement targets regardless of anticipated variations in those design variables.
- In **Type III robust design**, design variable values are determined which satisfy a set of performance requirements regardless of variations in the mathematical models used to describe that performance.
- In **Type IV robust design**, design variable values are determined which satisfy a set of performance requirements in spite of variability introduced by a hierarchical, multiscale or multidisciplinary formulation of the product (not considered in the following).

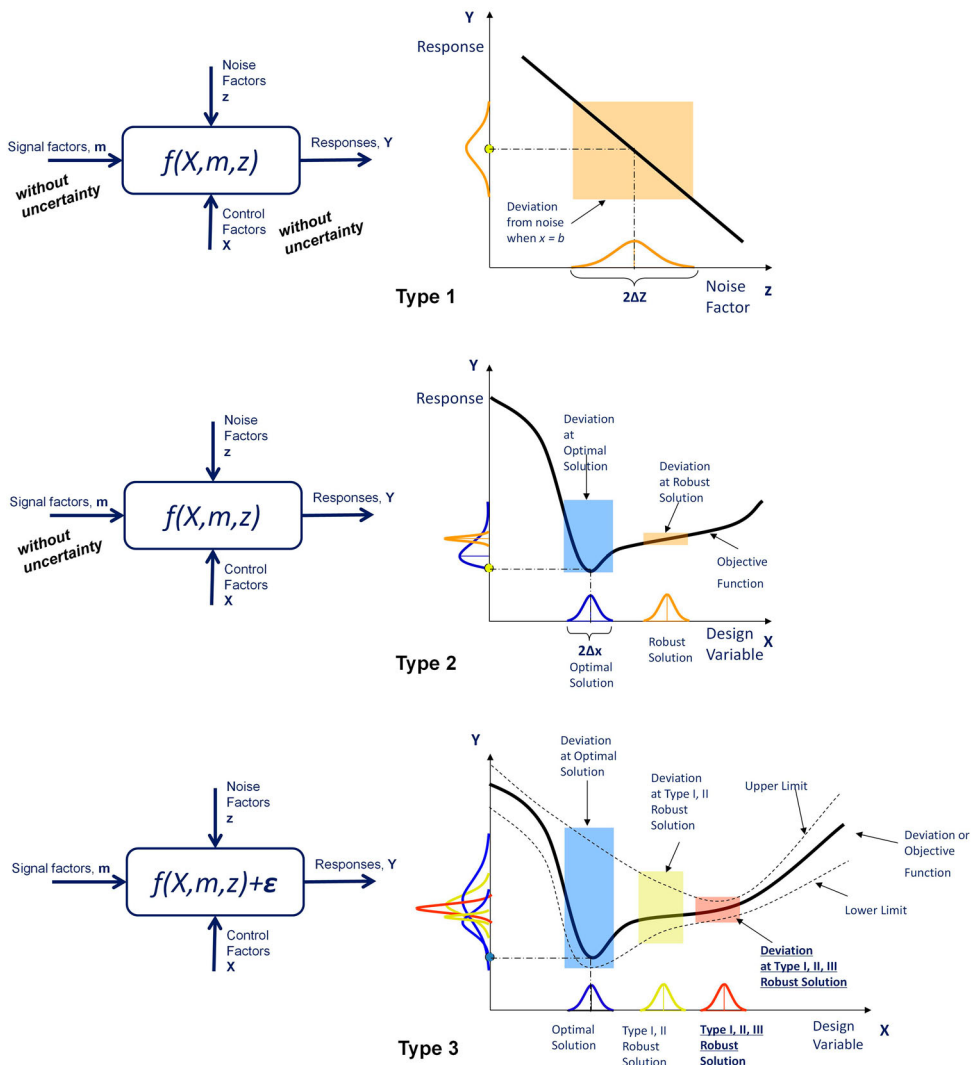

Figure 3. Classification of Robust design.

2.2. Current practices of robust parametric design

2.2.1. Type 1 robust analysis – choosing parameter combinations

The first category in Choi's (2005) framework summarizes the fundamental RD idea as advocated for example by Taguchi (1987) or Phadke (1995). The corresponding identification and choice of suitable design parameter combinations for a set of non-controllable noise influences is usually threefold: (1) definition of design matrices for crossed-array experiments [uncertainty modelling], (2) calculation/experimentation for each design point [uncertainty propagation], and (3) choice of suitable parameter combinations [data analysis]. While also criticized for its simplified statistical considerations, e.g. in Nair et al. (1992), the basic assumptions of this parameter design phase provide an important foundation for all further uncertainty management considerations in the remainder of this paper.

Fundamentally, the variation of noise factors can be considered a largely aleatoric uncertainty, i.e. as the natural variability of ambient conditions, of machine tolerances, etc. Theoretically, the degree of uncertainty is therefore primarily depending on the sampling size and the efficiency of calculating the uncertainty propagation (Choi 2005). However, the concrete relation between non-controllable Noise Factors (NF) and Control Factors (CF), as well as their influence on the signal-response relationship, is usually considered unknown, too expensive to evaluate respectively. For this reason, and despite the aleatoric nature of noise factors, a parameter study traditionally relies on evaluating a limited number of design points, and a simplified evaluation of resulting performance and variation based on Signal to Noise Ratios (SNR), exemplarily provided for a nominal-is-best characteristic below:

$$SNR = 10 \log \left(\frac{\bar{y}}{\sigma^2} \right)$$

The traditional Taguchi approach consequently focusses on a cost and time efficient evaluation of pre-defined parameter combinations, and appreciates the fact that largely uncertain and non-controllable noise factors cannot, respectively should not, be described at all costs. In other words, for an efficient analysis it is necessary to accept a certain level of epistemic uncertainty. Shin Taguchi for example states that *'the goal in parameter design is not to characterize the system but to achieve robust function'* (Nair et al. 1992).

2.2.2. Type II robust analysis – optimisation of control factors

Despite the indisputable contributions of traditional Parameter Design, a largely simplified description of the system under consideration naturally comes with disadvantages. This holds particularly true when looking at the possibilities of modern simulation-based design, offering an enormous potential for a reduction of uncertainty, efficient analyses as well as robustness improvements. For this reason, the first category of RD approaches is extended by Type II Robust Design *'used to design systems that are robust to possible variation in system parameters as a design evolves'* (Choi 2005).

The essence of Type II robustness is that the simplified consideration of largely unknown control-by-noise interactions is complemented by a detailed analysis and optimization of the control factors themselves. Instead of at single design points, the effect of control factors is evaluated based on available models for the product behavior model. Usually given in form of a simulation, this behavior model $f(x)$ allows for significantly reducing the epistemic uncertainty of control factors as well as the corresponding tolerances. As also illustrated in Figure 3, the aim is to search the entire design range for finding flat, hence robust, regions of the behavior model instead of an optimal performance, as the latter frequently results in significant losses in case of the slightest variation around the design point. Given the corresponding trade-off between the performance and its variation, also shown by the mean $\mu(x)$ and the standard deviation $\sigma(x)$ in the usual objective function of a Robust Design Optimisation (RDO) task, Type II robustness, however, implies the additional challenge of finding the right compromise between these objectives.

$$\min f(x) = \alpha \mu(x) + (1 - \alpha) \sigma(x)$$

Literature suggests several strategies for studying the given trade-off beyond just identifying the actual Pareto Set. Besides examples such as aggressive/conservative trade-off

strategies (Otto and Antonsson 1991) or the formulation as compromise design support problem (Mistree et al. 1990), work on preference modelling under uncertainty (Quirante, Sebastian, and Ledoux 2013; Mourelatos and Liang 2005) is the most relevant in the context of this work. As decision support, Quirante, Sebastian, and Ledoux (2013) choose to qualify the degree of customer satisfaction based on desirability functions. In this way, the presented approach complements a strictly stochastic, hence aleatoric, description of control factors by a suitable strategy to treat epistemic uncertainty for aspects that cannot be described in more detail.

2.2.3. Type III robust analysis – model uncertainty

In general, simulation-driven design implies epistemic uncertainty given by the used computational models (Oberkampf et al. 2002; Walter, Storch, and Wartzack 2014) as the behavior model from Type II Robustness is unknown and needs to be constructed, e.g. based on numerical simulations. Choi (2005), therefore, describes Type III robustness as the identification of ‘ranges for control factors, that satisfy a set of performance requirement targets and/or performance requirement ranges and are insensitive to the variability within the model.’

Addressing the involved computational costs of Type III robustness, particularly in case of an increasing parameter space, literature provides both, suitable experimental designs for computer experiments (Lehman, Santner, and Notz 2004; Joseph et al. 2019), as well as different surrogate-modelling techniques on the approximation accuracy of the used model (Chen et al. 1996; Chatterjee et al. 2019). Furthermore, several authors present possibilities to quantify the corresponding model uncertainty based on statistical uncertainty propagation techniques (Apley, Liu, and Chen 2005, Du and Chen 2000). As Choi (2005) states, a statistical treatment has a natural limit though, and can only be applied for relatively simple problems, particularly during design exploration.

In light of the ever-increasing complexity of engineering systems, and following the fundamental idea of an efficient robustness analysis from Type I, it is hence critical for an efficient analysis to clearly differentiate between the different types of uncertainty when using model-based predictions. Parameters can either be constant but not (fully) known (e.g. due to model discrepancy, limited samples for fitting model parameters, etc.), or just varying randomly (e.g. the aleatory variation of produced component dimensions). In robust parameter design, this difference has for example been considered based on the concept of so-called P(robability)-Boxes (Rumpfkeil 2013), see also Figure 4. Providing a suitable visualization for the upper and lower bounds of the resulting output distribution, the effect of the corresponding epistemic variables are derived by a maximization and a minimization

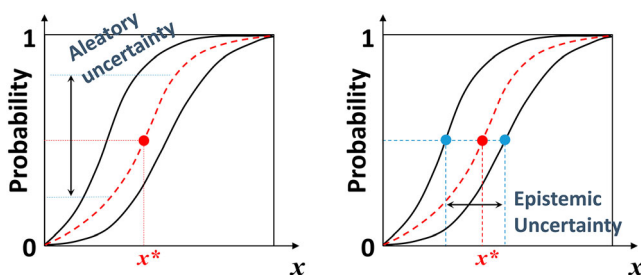

Figure 4. Representation of aleatory and epistemic uncertainty in P-Boxes.

problem instead of a sampling-based uncertainty propagation method. Furthermore, corresponding analysis were extended based on the characterization of epistemic uncertainty by means of the Evidence (Dempster-Shafer) theory (Filippi et al. 2018, Helton et al. 2010). A generalization of the Bayesian theory, the resulting uncertainty propagation is calculated and represented by an interval of lower bound (called believe) and an upper bound (called plausibility).

3. Tolerancing and uncertainty management

Following the basic idea of the classification of uncertainty management techniques in the context of robust parameter design, the aim of this chapter is to introduce and present a similar framework for Tolerancing. While Hong and Chang (2002) distinguished tolerance-related research into seven distinct categories: Tolerance modeling and representation, Tolerance schemes, Tolerance specification, Tolerance analysis, Tolerance synthesis or allocation, Tolerance transfer, Tolerance evaluation, the suggested framework focuses specifically on Tolerance analysis. Essential in the tolerancing process, the analysis provides the basis for Tolerance synthesis, Tolerance transfer and Tolerance evaluation, and, similar to the parameter design phase, includes questions of uncertainty modeling, uncertainty propagation, and the corresponding data analysis.

Shen, Aameta, and Shah J (2005) said: *'The objective of tolerance analysis is to check the extent and nature of the variation of an analyzed dimension or geometric feature of interest for a given GD&T scheme. The variation of the analyzed dimension arises from the accumulation of dimensional and/or geometrical variations in the tolerance chain'*. The extended definition used in the following is *'propagation of geometrical imperfections & gaps to check the respect of functional requirements'* (Dantan et al. 2012a). The purpose of this extension is to extended definition include the multi-physics aspect of tolerance analysis, i.e. the computation how geometrical imperfections influence the mechanical behavior or/and multiple simultaneous physical phenomena in a multiphysical system. This section deals with the current practices in tolerance analysis: tolerances chain and the tolerance analysis of non-rigid mechanisms; and with some extended practices with various uncertainties.

3.1. Basic concepts and fundamental classification

There are various classifications of tolerance analysis in literature. The classically used criteria are the type and technique of the analysis, the type of mathematical model for the product behavior, and the granularity of the geometrical modelling.

The most known classification is the distinction of worst-case and statistical tolerancing (Dantan et al. 2012b): Worst-case tolerance analysis involves establishing the tolerances such that any possible combination produces a functional assembly, i.e. the probability of non-assembly is equal to zero. It considers the worst possible combinations of individual tolerances on the basis of a previously identified geometrical characteristic relevant for ensuring the product function. On this very same basis, Statistical tolerancing involves establishing the tolerances such that a small fraction of assemblies is not assemblable or does not function as required (Chase and Parkinson 1991; Evans 1974; Morse et al. 2018; Nigam and Turner 1995).

Based on the mathematical point of view, the classification of the tolerance analysis techniques is displacement accumulation or tolerance accumulation (Dantan et al. 2012b; Dumas and Dantan 2015): The displacement accumulation simulates the influences of all deviations on the geometrical behavior of the mechanism. The tolerance accumulation simulates the composition of tolerances i.e. linear tolerance accumulation, 3D tolerance accumulation.

Based on the impact on the mathematical formulation for the problem of tolerance analysis, Ballu, Plantec, and Mathieu (2009) furthermore propose to distinguish two main mechanism categories in terms of degree of freedom: Iso-constrained mechanisms, and over-constrained mechanisms. The authors justify this classification by the fact that: *'Isoconstrained mechanisms are quite easy to grasp. Geometrical deviations within such products do not lead to assembly problems; the deviations are independent and the degrees of freedom catch the deviations. When considering small deviations, functional deviations may be expressed by linear functions of the deviations.'* and *'Considering overconstrained mechanisms is much more complex. Assembly problems occur and the expression of the functional deviations is no more linear. Depending on the value of the manufacturing deviations: the assembly is feasible or not and the worst configuration of contacts is not unique for a given functional deviation. For each overconstrained loop, events on the deviations have to be determined: events ensuring assembly and events corresponding to the different worst configurations of contacts. As there are different configurations, the expression of the functional deviation cannot be linear.'*

In the same way, Dantan et al. (2012b) develop a classification based on the mathematical issue and the type of response function f . The result of this classification is the aggregation of the three previous ones and the identification of the scope of application of all techniques: In the case of a nonlinear response function, the tolerance accumulation technique must not be used. For worst-case analyses, the tolerance accumulation technique should be preferably used.

In an additional direction, Schleich et al. (2014; Schleich and Wartzack 2016) analyze the impact of the granularity when modelling geometric deviations on the result of the tolerance analysis. They distinguish several granularities: 1D, 2D, 3D, 3D with form defect; and they illustrate the relationship between accuracy and granularity.

Following the above review, and combining it with the idea of the Parameter Design classification above, we propose to classify the different types of tolerance analyses based on the potential uncertainty. This leads to the following three categories:

- **Type I:** Verify Tolerance values that satisfy a set of geometrical requirement targets despite variation in noise factors (only geometrical imperfections or clearances).
- **Type II:** Verify Tolerance values that satisfy a set of performance requirements (geometrical or multiphysics) targets despite variation in noise factors (geometrical imperfections, deformations, clearances, ...).
- **Type III:** Verify Tolerance values that satisfy a set of performance requirements (geometrical or multiphysics) targets despite variation in noise factors (geometrical imperfections, deformations, clearances, ...) and variability within the model.

Correspondingly, the suggested framework complements current tolerancing practices, which mostly focus on aleatory uncertainty (Type I & II), by a distinct consideration of

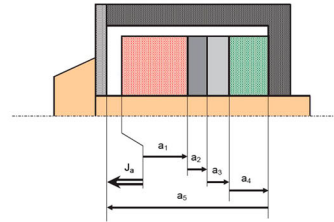
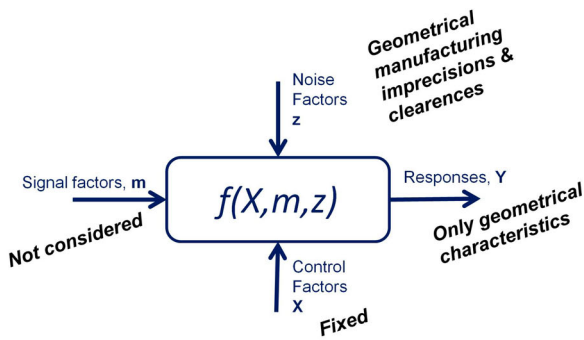

Type 1

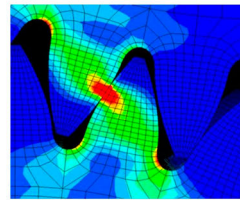
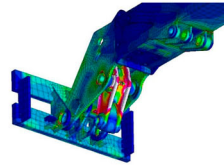
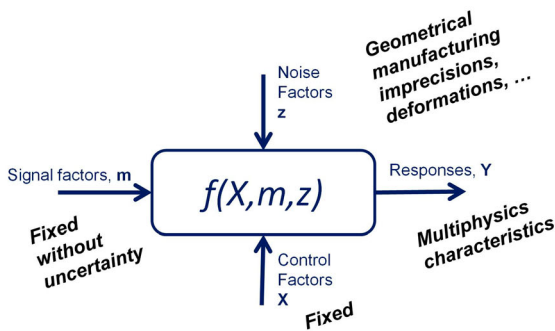

Type 2

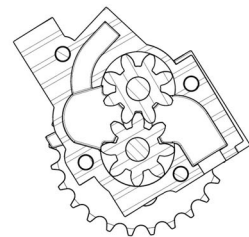
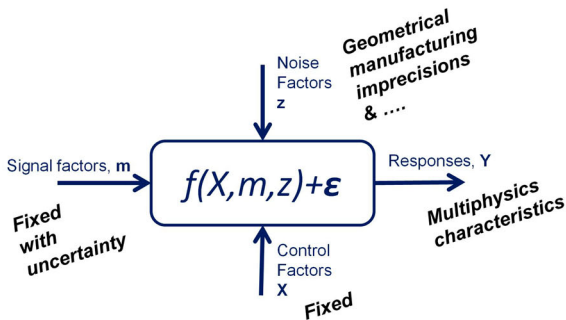

Type 3

Figure 5. Classification of Tolerance analysis issue.

epistemic uncertainty in the calculation model used (Type III). The made extension consequently accounts for the increasing possibilities of multiphysical simulations, which make the evaluation of tolerances computationally costly and time-intensive when addressed based on the usual, stochastic description of production variation around previously fixed control factor settings (Figure 5).

3.2. Available tolerancing approaches

3.2.1. Type 1 tolerance analysis

The Type 1 is the verification of Tolerance values that satisfy a set of geometrical requirement targets despite variation due to geometrical imperfections or clearances, as also highlighted by the P_diagram of Type 1 Tolerance analysis in Figure 5.

A simple illustration of Type 1 tolerance analysis is the classical dimensional chain (Figure 5). The designer identifies a functional clearance, which affects the overall mechanism function, and identifies all component dimensions influencing it. The mathematical formalization of the corresponding topological loop then allows the determination of the response function, a step that can be generalized to other geometrical characteristics (position or orientation) and to complex mechanisms with several topological loops (Dantan et al. 2012b).

The formalization and the calculation of the response function $f(X, z)$ (Dantan et al. 2012b), which is the mathematical model of the tolerance chains (Dumas and Dantan 2015), are based on the geometrical and topological properties of the mechanism, and the two conditions to be verified::

- Assemblability condition or Existential condition (Qureshi, Dantan, and Bigot 2009): *'For all acceptable geometrical deviations (which are inside tolerances), there exists a gap configuration such as the assembly requirements and the geometrical behavior constraints are verified'*
- Functional condition or Universal condition – *'For all acceptable geometrical deviations (which are inside tolerances), and for all admissible gap configurations, the assembly and functional requirements and the geometrical behavior constraints are verified'*.

To verify these conditions, the effectiveness of mathematical techniques depends on the mathematical formulation of the geometrical behavior of the mechanism. In the case of isoconstrained mechanisms or simple overconstrained mechanism, it is possible to easily define the response function $Y = f(X,z)$ (Ballu, Plantec, and Mathieu 2009), and several current mathematical techniques could be used. In the case of overconstrained mechanism, the calculation of the response function requires the determination of the worst configuration of gaps though, so that only the Minkowski sum (for tolerance accumulation) (Ledoux, Teissandier, and Sebastian 2016), or Monte Carlo simulation coupled with optimization or several system reliability methods (for displacement accumulation) can be used (Dumas and Dantan 2015).

Standard commercial tolerancing software performs Type 1 tolerance analysis in the case of isoconstrained mechanisms or simple overconstrained mechanism. In the case of overconstrained mechanism, most industrial practices are based on the decomposition of the kinematic configurations and the simplification of the response function, which are not consistently efficient. Moreover, several simplified behavior models are used for this type of analysis (kinematic joints without form defects, geometrical simulation without deformations, ...), which largely affects the accuracy of results (Ballu, Plantec, and Mathieu 2009).

3.2.2. Type 2 tolerance analysis

Often ignored in traditional analyses is the fact that geometrical deviations not only affect the geometrical behavior of a mechanism, but that these also lead to other noise factors, such as deformations, leading to additional effects on the geometrical behavior. Therefore, Type 2 tolerance analysis refers to the verification of Tolerance values that satisfy a set of geometrical or multiphysical performance requirement targets despite variation in noise factors that include geometrical imperfections, deformations, clearances, The P_diagram of Type 2 Tolerance analysis (Figure 5) shows that the mechanism is considered as signal-response relationship, which integrates the definition of the signal factors and mathematically represents the ideal function as embodied by the design concept. Usually, this signal-response relationship represents the behavior of the mechanism and models several multiphysical phenomena. The main objective of Type 2 Tolerance analysis is to propagate the geometrical deviations based on this signal-response relationship.

An example of Type 2 is the analysis of gear tolerances. In fact, the geometrical deviations have an impact on the transmission error, the tooth contact position, the meshing interference, the stress ... (Dantan 2015). There is a 'domino effect': geometrical deviations impact the tooth contact position, which impacts the stress, hence the distortions, which in turn affect the tooth contact position. The impact of the geometrical deviations and the distortions are coupled.

In this case, the formalization and the calculation of the response function $f(X,m,z)$ are based on the geometrical and topological properties of the mechanism, the multiphysical behavior laws, two extended conditions and a discretization of the modelling like Finite Element Method. The aim of the extended conditions is to integrate the deformations or distortions and the multiphysical aspect of the behavior of the mechanism:

- Assemblability condition or Existential condition – 'For all acceptable geometrical deviations (which are inside tolerances), there exists a gap configuration and **acceptable distortions** such as the assembly requirements and the **multiphysical** behavior constraints are verified'. In this condition, distortions facilitate the assembly.
- Functional condition or Universal condition – 'For all acceptable geometrical deviations (which are inside tolerances), for **all acceptable distortions** and for all admissible gap configurations, the assembly and functional requirements and the **multiphysical** behavior constraints are verified'. In this condition, distortions do not facilitate the respect of the universal condition.

The effectiveness of mathematical techniques depends on the coupling of the geometrical behavior modelling and the multiphysical behavior modelling (Deng et al. 2017), usually in form of an analysis of component deformation. The most commonly used techniques are the Monte Carlo Simulation coupled with Finite Element Methods (Camelio, Hu, and Ceglarek 2003; Dahlström and Lindkvist 2004; Jareteg et al. 2014; Söderberg et al. 2012) and several probabilistic method (FORM, ...) (Goka et al. 2019). In fact, Monte Carlo simulation remains the reference method but requires many mechanical computations that makes it very difficult to use in practice for industrial applications. The increasing interest of accurate but time consuming numerical methods, such as the Finite Element Methods for the prediction of mechanical behavior, has involved the development of approximated probabilistic

methods (Dantan et al. 2012b): FORM system, Response Surface Method, Support Vector Machine, Kriging method,...

Several commercial software tools allow for performing a simplified Type 2 tolerance analysis, that is usually focusing on single component behavior and does not consider gaps. We identify two main industrial practices:

- Complete decoupling of the geometrical simulation with geometrical deviations and the multiphysical behavior simulation without geometrical deviations by Finite Element Method and the accumulation of the effects on the functional requirements.
- A multiphysical behavior simulation with some simple geometrical deviations with a Monte Carlo simulation.

Considering the probability computation of multiphysical behavior including the existence of gaps, the literature on that subject seems to be very poor. We identify only several applications for gear analyses (Bruyere et al. 2007; Dantan 2015).

3.3. Extension of current approaches to Type 3 tolerance analysis

The Type 3 Tolerance analysis is an uncharted territory. The Type 2 Tolerance analysis considers the description of geometrical behavior and multiphysical relationships as perfect. In reality, the used models are, however, affected by several uncertainties: model uncertainty, parameter uncertainty ... , which has an impact on the accuracy of the results. Accordingly, Type 3 is the verification of Tolerance values that satisfy a set of performance requirements (geometrical or multiphysics) targets despite variation in noise factors (geometrical imperfections, deformations, clearances,...) and variability within the model (Figure 5).

An example of tolerance type 3 is the tolerance analysis of a pump, where clearances have a significant impact on the achievable efficiency. To simulate the impact of the clearances on the hydraulic flow, it is, however, necessary to formalize several assumptions about the fluid behavior (Malmiry et al. 2016). These assumptions are the cause of model errors, and additional approaches are needed to efficiently quantify and propagate the corresponding effects in the tolerance assessment of the pump. A corresponding approach to propagate all uncertainties – manufacturing imprecisions and model uncertainties – is proposed in the following section.

3.4. Proposed techniques to perform uncertainty management during tolerancing

In the context of Type 3 Tolerance Analysis, there are two types of uncertainty that have to be distinguished: Aleatory and epistemic uncertainty. Similar to the robust design tasks reviewed above, the key challenge is consequently the question of a heterogeneous uncertainty propagation, i.e. how to model and propagate different types of uncertainty through the used model (signal-response relationship) to allow for an efficient and meaningful data analysis.

There are many ways of modelling epistemic uncertainty. A simple way to propagate epistemic uncertainty is by interval analysis (Du 2006). In interval analysis, it is assumed that the uncertain variables lie within certain intervals. That is, there is no particular structure on the possible values for the uncertain variables. The problem of uncertainty propagation

then becomes an interval analysis problem. An efficient approach is to use optimization to find the maximum and minimum values of the responses, which correspond to the upper and lower interval bounds on the responses. There are a number of optimization algorithms, which solve bound constrained problems. Another approach is to use surrogates to determine interval responses bounds; the surrogate methods involve constructing response surface approximations of signal-response relationship. The second way to propagate epistemic uncertainty is Dempster-Shafer Evidence theory (Dempster 1967), which is an efficient approach because it is a generalization of classical probability theory. In Dempster-Shafer evidence theory, the epistemic uncertain variables are modeled as sets of intervals. The intervals are propagated to estimate belief and plausibility. Belief is the lower bound on a probability value that is consistent with the evidence, and plausibility is the upper bound on a probability value that is consistent with the evidence. Therefore, belief and plausibility define an interval-valued probability distribution. This approach allows to propagate both aleatory and epistemic uncertainty.

Inspired by the review of robust design, the proposed approach is an aggregation of these two techniques above. We proposed to combine Monte Carlo simulation and optimization. The optimization allows for identifying the worst configurations of the responses of each sample of the aleatory uncertainty (geometrical deviation). Figure 6 shows the proposed general flow chart describing the uncertainties propagation techniques. To compare several approaches of epistemic uncertainty propagation, the proposed framework includes:

- Statistical tolerance analysis without taking into account the epistemic uncertainty; the outputs are the classical results of Type 2 tolerance analysis: the failure rate in ppm and the cumulative distribution function (CDF) of the functional characteristics without consideration of epistemic uncertainty,
- Statistical tolerance analysis and probabilistic propagation of the epistemic uncertainty; the outputs are the failure rate in ppm and the cumulative distribution function (CDF) of the functional characteristics; usually, they were estimated by several techniques of the Type 2 robust design approach.
- Statistical tolerance analysis coupled with optimization to perform the evaluation of the cumulative belief and plausibility functions (Plausibility CDF & Belief CDF to represent the pessimistic and the optimistic case); this evaluation can be done by modifying a technique of the Type 3 robust design approach: monte carlo simulation and optimization.

3.5. Case study

To illustrate this framework, the Type 3 tolerance analysis is performed on an External gear pump (Figure 7). The efficiency and oil flow of the pump depend on different backlashes. These backlashes are between the gears and the housing as well as between the gears and shafts. The manufacture of the current oil pump expects a minimum oil flow of 4.35×10^{-14} m³/s.

To analyze the impact of the tolerance allocation and the model imprecision, we perform three case studies with two different sets of tolerances (case study 1 and case studies 2 & 3) and with two different sets of model parameter imprecisions (case studies 1 & 2 and

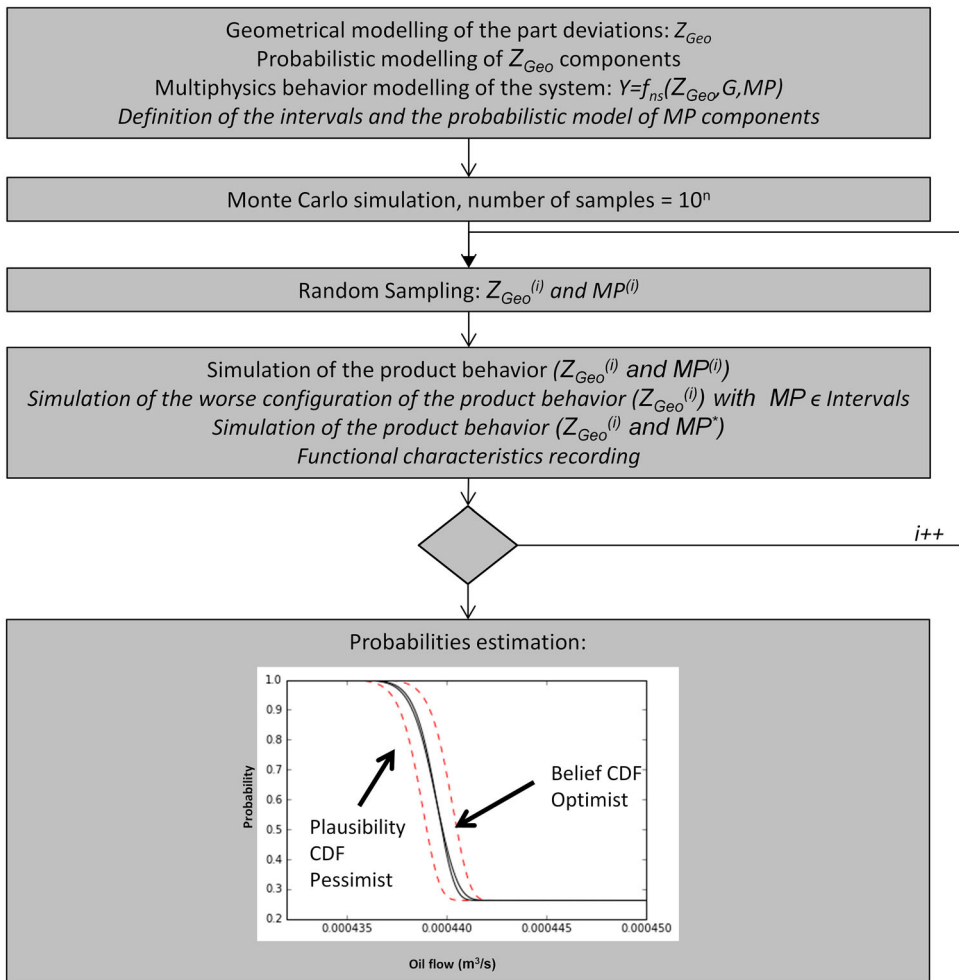
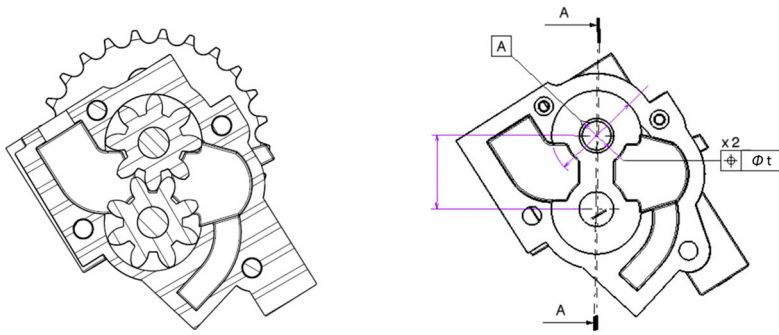

Figure 6. Algorithm for Type 3 Tolerance analysis.

case study 3). Figure 6 summarizes all considered geometrical characteristics, their nominal values, their tolerances, and their standard deviations. One tolerance (location of bearings) of the case study 1 is greater than those of the case studies 2 & 3. The model imprecisions of the case study 3 are greater than those of the case studies 1 & 2.

The used geometrical model and tolerance analysis technique of this external gear pump were detailed in Dumas and Dantan (2015). Monte Carlo simulation is used to simulate the deviations and the optimization to identify the worst gap configuration. The intermediate result of the Monte Carlo simulation coupled with the optimization is a statistical distribution of all functional backlashes. The estimation of the leakage rate is based on a surrogate model, which depends on the functional backlashes between gears, pump housing and the shaft, and four model parameters (MP: a, b, c, d – Figure 7). The estimation of these model parameters and their confidence intervals is done based on experimental results and results of finite element simulations. The statistical distributions of the leakage rate and the



Geometrical characteristics	Nominal value	Case study 1		Case studies 2 & 3	
		Tolerance	Standard deviation	Tolerance	Standard deviation
Gear					
Head length of the teeth	1,8 mm	0,4	0,05	0,4	0,05
Primitive length of the teeth	4,9 mm	0,4	0,05	0,4	0,05
Base length of the teeth	9,8 mm	0,4	0,05	0,4	0,05
Gear thickness	21,4 mm	0,08	0,01	0,08	0,01
Gear diameter	56,5 mm	0,08	0,01	0,08	0,01
Root diameter	19 mm	0,08	0,01	0,08	0,01
Tooth depth	6 mm	0,4	0,05	0,4	0,05
Pump housing					
Diameter of the housing pocket for the gear	56,8 mm	0,08	0,01	0,08	0,01
Depth of the housing pocket for the gear	21,5 mm	0,08	0,01	0,08	0,01
Localization of the bearings		0,045	0,009	0,03	0,006
Bearing diameter	10,03 mm	0,015	0,003	0,015	0,003
Shaft					
Shaft diameter	10 mm	0,015	0,003	0,015	0,003
Shaft length	22 mm	0,08	0,01	0,08	0,01

Model Parameter	Estimated value	Case studies 1 & 2	Case study 3
a	2.75	[2.72, 2.78]	[2.70, 2.80]
b	235	[234.6, 235.4]	[233, 237]
c	500000	[497000, 503000]	[490000, 510000]
d	19.8e-3	[19.3e-3, 20.3e-3]	[19e-3, 20e-3]

Figure 7. Use Cases.

oil flow are calculated from the statistical distribution of all functional backlashes and from the surrogate model.

The results (Figure 8) of the three case studies include;

- the cumulative belief and plausibility functions (Belief CDF and Plausibility CDF),
- the cumulative distribution functions (continuous curves – CDF of classical tolerance analysis and CDF of tolerance analysis with the probabilistic propagation of the model parameter imprecision),
- $\text{Proba}_{\text{optimist}}(Q > 0,000435 \mid \text{assembly})$: optimistic non-conformance rate that represents the impact of manufacturing imprecision on the respect of the functional requirement estimated in the optimistic configuration of the model parameter imprecision,

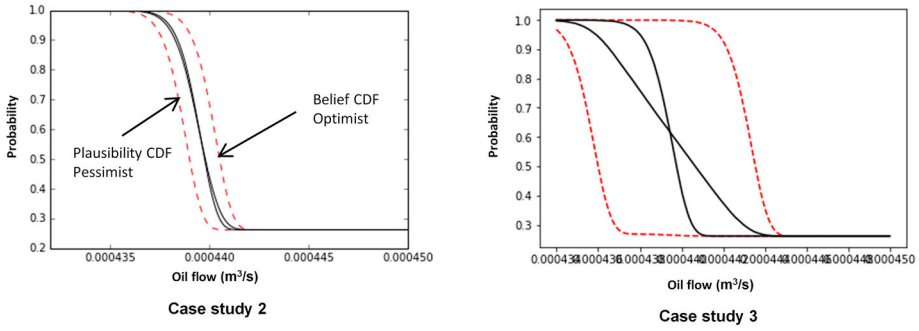

	Case study 1		Case study 2		Case study 3	
	Probability of conformance	Non conformance rate in ppm	Probability of conformance	Non conformance rate in ppm	Probability of conformance	Non conformance rate in ppm
$Proba_{optimist}(Q>0,000435 \text{ \& assembly})$	0,992953	7047	0,999656	344	0,999663333	336,66667
$Proba_{pessimist}(Q>0,000435 \text{ \& assembly})$	0,992406	7594	0,999252	748	0,83954	160460
$Proba_{without}(Q>0,000435 \text{ \& assembly})$	0,992806	7194	0,999594	406	0,999596	404
$Proba_{with}(Q>0,000435 \text{ \& assembly})$	0,992763	7237	0,99955	450	0,99892	1080
$Proba_{(assembly)}$	0,993	7000	0,999662	338	0,99967	330
$Proba_{optimist}(Q>0,000435 \text{ assembly})$	0,99995	50	0,999994	6	0,999993331	7
$Proba_{pessimist}(Q>0,000435 \text{ assembly})$	0,999402	598	0,99959	410	0,83981714	160183
$Proba_{without}(Q>0,000435 \text{ assembly})$	0,999805	195	0,999932	68	0,999925976	74
$Proba_{with}(Q>0,000435 \text{ assembly})$	0,999761	239	0,999888	112	0,999249752	750

Figure 8. Results.

- $Proba_{pessimist}(Q > 0,000435 \text{ | assembly})$: pessimistic non-conformance rate that represents the impact of manufacturing imprecision on the respect of the functional requirement estimated in the pessimistic configuration of the model parameter imprecision,
- $Proba_{without}(Q > 0,000435 \text{ | assembly})$: classical non-conformance rate that represents the impact of manufacturing imprecision on the respect of the functional requirement,
- $Proba_{with}(Q > 0,000435 \text{ | assembly})$: probabilistic non-conformance rate that represents the impact of all uncertainties (manufacturing imprecision and model parameter imprecision) on the respect of the functional requirement estimated by a probabilistic propagation,

These results highlight:

- the impact of the model parameter imprecision: For each case study, the differences between non-conformance rates are not negligible. For example, the confidence interval of the non-conformance rate of the case study 1 is [50, 598 ppm] that the interval limits are the worst configurations of the non-conformance rate due to the epistemic uncertainty. The differences between the Belief CDF and Plausibility CDF represent the impact of the model parameter imprecision on the probability of oil flow requirement (Figure 8).
- the impact of the epistemic uncertainty propagation techniques: Two techniques of epistemic uncertainty propagation are compared: uncertainty propagation using a worst case modelling and uncertainty propagation using a probabilistic modelling. For example, the non-conformance rate of the case study 1 varies between 50, 239 and 598 ppm regarding the uncertainty modelling of the model parameter imprecision.

- The impact of the model accuracy: The differences between the results of the case studies 2 and 3 are due to the model accuracy. The case study 3 uses a rough model; the impact of the model parameter imprecision is too important to ignore: [7, 160183 ppm]
- The impact of the tolerance allocation: the differences between the results of the case studies 1 and 2 are only due to one tolerance.

Several differences between results are due to the accuracy of the Monte Carlo simulation. The confidence interval of each non-conformance rate estimation is equal to 8 ppm. For example, the classical non-conformance rates of the case studies 2 and 3 must be equal (68 and 74 ppm). The highlighted impacts are much greater than the impact of the accuracy of the Monte Carlo simulation. All results illustrate the importance of the Type 3 tolerance analysis.

4. Conclusion

The first sentence of the introduction is '*Uncertainty is ubiquitous in engineering design*'. And as the conclusion of this paper is '*Indeed uncertainty is ubiquitous in tolerancing*', it can be stated that the objective of tolerancing is the efficient management of the uncertainty in geometrical variabilities: how to limit them? How to ensure the assemblability and functional conditions?

While usually considered as purely aleatory uncertainty, this paper aims at extending this classical view, and to highlight the influence of other uncertainties on the tolerancing activity. The state of art on the robust design taxonomy shows that different types of uncertainty are considered during the parameter design, and all of them have an impact on the results. Based on this state of art, a taxonomy of tolerance analysis issue is proposed, which is complementary to other available classifications, and is based on the uncertainty point of view: Which uncertainties are considered?

The taxonomy distinguishes between three types of tolerance analysis, extending traditional approaches that usually neglect epistemic uncertainty due to model parameter imprecision or model error. Complementary, we propose a framework to propagate all uncertainties and to quantify the impact of the epistemic uncertainty on tolerance analysis results. The application of the framework is demonstrated through an industrial case study, which illustrates the significant impact of the model parameter imprecision on the results and the need to consider them.

The selection of the tolerance analysis strategy regarding the 3 types depends on the significance of the impact of the distortion and the significance of the impact of the accuracy of the behavior model of the product. Only, the type 3 should take into account the model uncertainty: if the accuracy of the behavior model is poor then type 3 must be performed.

Note

1. Research work on early stage Robust Design methods/tools can, applicable in the System Design phase, can for example be found in Eifler and Howard (2018), or Eifler, Christensen, and Howard (2013).

Acknowledgements

The authors would like to acknowledge the French Higher Education Ministry and the Arts et Métiers foundation for their financial support under the sabbatical year of Prof. Jean-Yves Dantan at DTU.

Disclosure statement

No potential conflict of interest was reported by the author(s).

Funding

This work was supported by the French Higher Education Ministry has supported my sabbatical year (01/09/2019 - 31/08/2020) and the Arts et metiers foundation (<https://fondationartsetmetiers.org/>) for my sabbatical year(01/09/2019 - 31/08/2020) for their financial support under the sabbatical year of Prof. Jean-Yves Dantan at DTU.

ORCID

Jean-Yves Dantan  <http://orcid.org/0000-0002-0491-8391>

Tobias Eifler  <http://orcid.org/0000-0002-1293-3313>

References

- Apley, D. W., J. Liu, and W. Chen. 2005. "Understanding the Effects of Model Uncertainty in Robust Design With Computer Experiments." *Journal of Mechanical Design* 128 (4): 945–958.
- Ballu, A., J.-Y. Plantec, and L. Mathieu. 2009. "Geometrical Reliability of Overconstrained Mechanisms with Gaps." *CIRP Annals – Manufacturing Technology* 57: 159–162.
- Bruyere, J., J.-Y. Dantan, R. Bigot, and P. Martin. 2007. "Statistical Tolerance Analysis of Bevel Gears." *Mechanism and Machine Theory* 42 (10): 1326–1351.
- Camelio, J., S. J. Hu, and D. Ceglarek. 2003. "Modeling Variation Propagation of Multi-Station Assembly Systems with Compliant Parts." *Journal of Mechanical Design* 125 (4): 673–681.
- Chase, K. W., and A. R. Parkinson. 1991. "A Survey of Research in the Application of Tolerance Analysis to the Design of Mechanical Assemblies." *Research in Engineering Design* 3 (1): 23–37.
- Chatterjee, T., S. Chakraborty, and R. A. Chowdhury. 2019. "Critical Review of Surrogate Assisted Robust Design Optimization." *Archives of Computational Methods in Engineering* 26: 245–274. doi:10.1007/s11831-017-9240-5.
- Chen, W., J. K. Allen, K. Tsui, and F. Mistree. 1996. "A Procedure for Robust Design: Minimizing Variations Caused by Noise Factors and Control Factors." *ASME. The Journal of Mechanical Design* 118 (4); December 1996: 478–485. doi:10.1115/1.2826915.
- Choi, H.-J. 2005. "A Robust Design Method for Model, Propagated Uncertainty." (PhD diss.) Georgia Institute of Technology.
- Dahlström, S., and L. Lindkvist. 2004. Variation simulation of Sheet Metal Assemblies Using the Method of Influence Coefficients with Contact Modeling. ASME 2004 International Mechanical Engineering Congress, Exposition, Anaheim, California.
- Dantan, J.-Y. 2015. "Comparison of Skin Model Representations, Tooth Contact Analysis Techniques for Gear Tolerance Analysis. Journal of Computing." *Information Science in Engineering* 15 (2). Article number 021010. doi:10.1115/1.4028961.
- Dantan, Qureshi, A.J., J.-F. Antoine, B. Eisenbart, and L. T. M. Blessing. 2013. "Management of Product Characteristics Uncertainty Based on Formal Logic, Characteristics Properties Model." *Annals of CIRP* 62 (1): 147–150.
- Dantan, Gayton, N., N. Dumas, A. Etienne, and A. J. Qureshi. 2012b. Mathematical issues in Mechanical Tolerance Analysis, AIP PRIMECA 2012, France.
- Dantan, J. Y., N. Gayton, A. J. Qureshi, et al. 2012a. Tolerance analysis approach based on the classification of uncertainty (aleatory/ epistemic). In: Proceedings of the 12th CIRP conference on computer aided tolerancing, Huddersfield, UK.
- Dempster, A. P. 1967. "Upper and Lower Probabilities Induced by a Multivalued Mapping." *The Annals of Mathematical Statistics* 38 (2): 325–339.

- Deng, J., X. Ye, Y. Lin, Q. Li, and G. Zhai. 2017. "A new Robust Tolerance Design Method for Electromechanical Device Based on Variable Contribution Rate Coefficients." *Journal of Engineering Design* 28 (7-9): 532–548.
- Du, X. 2006. "Uncertainty Analysis with Probability and Evidence Theories" Proceedings of ASME 2006 International Design Technical Conferences & Computers and Information in Engineering Conference, Sep 10-13, Philadelphia, Pennsylvania.
- Du, X., and W. Chen. 2000. "A Methodology for Uncertainty Propagation and Management in Simulation-Based Systems Design." *AIAA Journal* 38 (8): 1471–1478.
- Dumas, A., and Gayton, N. Dantan. 2015. "Impact of a Behavior Model Linearization Strategy on the Tolerance Analysis of Over-Constrained Mechanisms." *CAD Computer Aided Design* 62: 152–163.
- Ebro, M., and T. J. Howard. 2016. "Robust Design Principles for Reducing Variation in Functional Performance." *Journal of Engineering Design* 27 (1-3): 75–92.
- Eifler, M., E. Christensen, and T. J. Howard. 2013. A classification of the industrial relevance of robust design methods. 19th International Conference on Engineering Design.
- Eifler, T., and T. J. Howard. 2018. "The Importance of Robust Design Methodology: Case Study of the Infamous GM Ignition Switch Recall." *Research in Engineering Design* 29: 39–53. doi:10.1007/s00163-017-0251-x.
- Evans, D. H. 1974. "Statistical Tolerancing: The State of the Art: Part I. Background." *Journal of Quality Technology* 6 (4): 188–195.
- Filippi, G., M. Vasile, P. Z. Korondi, M. Marchi, and C. Poloni. 2018. Robust Design Optimisation of dynamical space systems, 8th International Systems & Concurrent Engineering for Space Applications Conference (SECESA 2018).
- Goka, E., P. Beaurepaire, L. Homri, and J.-Y. Dantan. 2019. "Probabilistic-based Approach Using Kernel Density Estimation for gap Modeling in a Statistical Tolerance Analysis." *Mechanism and Machine Theory* 139: 294–309.
- Helton, J. C., J. D. Johnson, W. L. Oberkampf, and C. J. Sallaberry. 2010. "Representation of Analysis Results Involving Aleatory and Epistemic Uncertainty." *International Journal of General Systems* 39 (6): 605–646. doi:10.1080/03081079.2010.486664.
- Hong, Y. S., and T. C. Chang. 2002. "A Comprehensive Review of Tolerancing Research." *International Journal of Production Research* 40: 2425–2459.
- Jareteg, C., K. Wärmefjord, R. Söderberg, L. Lindkvist, J. S. Carlson, C. Cromvik, and F. Edelvik. 2014. Variation simulation for composite parts, assemblies including variation in fiber orientation, thickness, CIRP CATS 2014.
- Joseph, V. R., L. Gu, S. Ba, and W. R. Myers. 2019. "Space-Filling Designs for Robustness Experiments." *Technometrics* 61 (1): 24–37. doi:10.1080/00401706.2018.1451390.
- Jugulum, R., and D. D. Frey. 2007. "Toward a Taxonomy of Concept Designs for Improved Robustness." *Journal of Engineering Design* 18 (2): 139–156. doi:10.1080/09544820600731496.
- Ledoux, Y., D. Teissandier, and P. Sebastian. 2016. "Global Optimisation of Functional Requirements and Tolerance Allocations Based on Designer Preference Modelling." *Journal of Engineering Design* 27 (9): 591–612.
- Lehman, J. S., T. J. Santner, and W. I. Notz. 2004. "Designing Computer Experiments to Determine Robust Control Variables." *Statistica Sinica* 14: 571–590.
- Malmiry, R. B., J. Pailhès, A. J. Qureshi, J. F. Antoine, and J.-Y. Dantan. 2016. "Management of Product Design Complexity due to Epistemic Uncertainty via Energy Flow Modelling Based on CPM." *Annals of CIRP* 65 (1): 169–172.
- Mistree, F., W. Smith, B. Bras, J. Allen, and D. Muster. 1990. "Decision-based Design: a Contemporary Paradigm for Ship Design." Transactions. *Society of Naval Architects and Marine Engineers* 98: 565–597.
- Morse, E., Anwer, N. Dantan, R. Söderberg, G. Moroni, A. Qureshi, X. Jiang, and L. Mathieu. 2018. "Tolerancing: Managing Uncertainty from Conceptual Design to Final Product." *CIRP Annals* 67 (2): 695–717.
- Mourelatos, Z. P., and J. Liang. 2005. "A Methodology for Trading-Off Performance and Robustness Under Uncertainty. ASME." *The Journal of Mechanical Design* 128 (4): 856–863.

- Nair, V. N., B. Abraham, J. MacKay, G. Box, R. N. Kacker, T. J. Lorenzen, J. M. Lucas, et al. 1992. "Taguchi's Parameter Design: A Panel Discussion." *Technometrics* 34 (2): 127–161.
- Nigam, S. D., and J. U. Turner. 1995. "Review of Statistical Approaches to Tolerance Analysis." *Computer Aided Design* 27 (1): 6–15.
- Oberkampf, W. L., S. M. DeLand, B. M. Rutherford, K. V. Diegert, and K. F. Alvin. 2002. "Error and Uncertainty in Modeling and Simulation." *Reliability Engineering and System Safety* 75: 333–357.
- Otto, K. N., and E. K. Antonsson. 1991. "Trade-off Strategies in Engineering Design." *Research in Engineering Design* 3 (2): 87–103. doi:10.1007/BF01581342.
- Pahl, G., W. Beitz, J. Feldhusen, and K.-H. Grote. 2007. *Engineering Design: A Systematic Approach* (3rd ed.), edited by K. Wallace, and L. T. M. Blessing. Springer-Verlag London Limited.
- Phadke, M. S. 1995. *Quality Engineering Using Robust Design*. New Jersey: Prentice Hall.
- Quirante, T., P. Sebastian, and Y. Ledoux. 2013. "A Trade-off Function to Tackle Robust Design Problems in Engineering." *Journal of Engineering Design* 24 (1): 64–81.
- Qureshi, J., Bruyere, J. Dantan, and R. Bigot. 2009. Tolerance Analysis based on Quantified Constraint Satisfaction Problems, 11th CIRP International Seminar on Computer Aided Tolerancing, Annecy, France.
- Rumpfkeil, M. P. 2013. "Robust Design Under Mixed Aleatory/Epistemic Uncertainties Using Gradients and Surrogates." *Journal of Uncertainty Analysis and Applications* 1 (1): 7. doi:10.1186/2195-5468-1-7.
- Schleich, Benjamin, Nabil Anwer, Zuowei Zhu, Lihong Qiao, Luc Mathieu, and Sandro Wartzack. 2014. A Comparative Study on Tolerance Analysis Approaches. Conference: International Symposium on Robust Design – ISoRD14.
- Schleich, B., and S. Wartzack. 2016. "A Quantitative Comparison of Tolerance Analysis Approaches for Rigid Mechanical Assemblies." *Procedia CIRP* 43: 172–177.
- Shen, Z., G. Aameta, and J. Shah J. 2005. "A Comparative Study of Tolerance Analysis Methods." *Journal of Computing and Information Science in Engineering* 5: 247–256.
- Söderberg, R., K. Wärmefjord, L. Lindkvist, and R. Berlin. 2012. "The Influence of Spot Weld Position Variation on Geometrical Quality." *Annals of CIRP* 61 (1): 13–16.
- Taguchi, G. 1987. *The System of Experimental Design Engineering Methods to Optimize Quality and Minimize Cost*, vols. 1 and 2. Dearborn, MI: American Supplier Institute.
- Thunnissen, D. P. 2003. Uncertainty classification for the design, development of complex systems, 3rd Annual Predictive Methods Conference. Newport Beach, California, 1–16.
- Walter, M., M. Storch, and S. Wartzack. 2014. "On Uncertainties in Simulations in Engineering Design: A Statistical Tolerance Analysis Application." *Simul. Trans. Soc. Model. Simul. Int* 90 (5): 547–559.
- Wang, R., A. Nellippallil, G. Wang, Y. Yan, J. Allen, and F. Mistree. 2019. "Ontology-based Uncertainty Management Approach in Designing of Robust Decision Workflows." *Journal of Engineering Design* 30 (10-12): 726–757.