



Science Arts & Métiers (SAM)

is an open access repository that collects the work of Arts et Métiers Institute of Technology researchers and makes it freely available over the web where possible.

This is an author-deposited version published in: <https://sam.ensam.eu>
Handle ID: <http://hdl.handle.net/10985/23304>

To cite this version :

Oussama ADJOUL, Khaled BENFRIHA, Améziane AOUSSAT - Algorithmic strategy for optimizing product design considering the production costs - International Journal on Interactive Design and Manufacturing (IJIDeM) - Vol. 13, n°4, p.1313-1329 - 2019

Any correspondence concerning this service should be sent to the repository

Administrator : scienceouverte@ensam.eu



Algorithmic strategy for optimizing product design considering the production costs

Oussama Adjoul¹ · Khaled Benfriha¹ · Améziane Aoussat¹

Abstract

This article describes a new interactive design approach integrating the constraints associated with production include manufacturing and assembling. The proposed method, in the form of an algorithm, allows optimisation of product design by minimizing production costs at each iteration, without compromising its functionality. The novelty of this algorithm in terms of modeling and optimisation of production costs in the design phase is its ability to dynamically evaluate the cumulative costs of production as a function of design and procedural choices. The availability of this information first allows the identification of design points and/or procedural points that generate significant production costs, and second, suggests improvements and recommendations that aim to optimize production costs. These experiments were conducted at a smart factory installed in our organisation. The proposed algorithm involves four steps. To optimise production costs, the designer must input all of the required data into the simulation and thereby identify the most significant cost elements to optimise. Then, the designer uses the suggested recommendation list to modify the relevant design and/or manufacturing parameters, thus obtaining the new, optimised production costs. If the first result is unsatisfactory, other iterations can be performed.

Keywords Design · Manufacturing · Iterative algorithm · Optimization of production costs · Dynamic modeling · Smart factory

1 Introduction

Over the past few years, industrialised countries throughout the world have continued to invest heavily in new technologies, software programs and services to advance product design and manufacturing using cyber-physical systems, connected machines, data analysis and high performance computing systems [1].

For manufacturing companies, this represents a real industrial revolution, referred to as “Industry 4.0”, in which value creation depends on the use of these new technologies [2]. In this new digital ecosystem, controlling the production cost of a product is not only an advantage, but has become a requirement.

Evaluating production costs (machining cost, assembly cost, cutting cost, etc.) is a strategic advantage that is necessary for product optimisation in the design phase. This evaluation can lead the designer to suggest another technological solution that provides the same functional characteristics but at a lower cost. In addition, the design phase accounts for 70–80% of costs, while the project accounts for only 5–10% of the total cost [3]. In addition, as the project advances further, the costs associated with making the changes needed to reduce the cost become greater. It is therefore important to control the cost parameter as early as possible in the lifecycle of a product or project.

In this context, it is necessary to communicate and share data between the different phases of a product’s life cycle using the interactive approach [4]. In addition, the design team should be composed of experts that are aware of the requirements of all product life cycle phases or multidisciplinary tools [5, 6]. This ensures that the product design corresponds to the best concepts and technological options [6]. To do this, the design team should be able to use interactive design tools and methods, such as simulation tools, analytical models, numerical analyses, and relevant design software

✉ Oussama Adjoul
oussama.adjoul@ensam.eu
Khaled Benfriha
khaled.benfriha@ensam.eu

¹ Laboratoire de Conception de Produits et Innovation, Arts et Métiers ParisTech, 151 boulevard de l’Hôpital, 75013 Paris, France

to improve product efficiency [7]. For example, decisions made during the early design phases (preliminary and detailed phases) have an influence on the choice of materials, geometric shape, mechanical connections between parts, etc. As a result, the production plan and time are affected, which impacts the production cost.

Currently, cost specialists can provide overall estimates in the design phase, but they cannot establish specific links to the technical characteristics of the product [8, 9]. Thus, the designers break down the overall cost into individual cost elements to understand or establish causal relationships between design choices and their impacts on production costs. From this succinct analysis, there arises a need to formalise a new interactive method that allows designers to optimise products through the use of a dynamic cost estimation, thus meeting current needs in the industry.

In this article, a new interactive design approach enabling a product to be modified from its original version toward a version that is optimised in terms of production costs (machining cost, assembly cost, cutting cost, etc.), without compromising its functionality, is proposed. The interactivity of this approach is the link created between the design phase and the production phase, which involves different causal relationships between design choices and their impacts on production costs. Indeed, manufacturing expertise is thus transferred and implemented in the design phase. This approach, in the form of an algorithm, enables improvements (technical solutions) in terms of design and manufacturing that will contribute to a reduction in the

production costs to be identified at each iteration. The contribution of this research is that it dynamically evaluated and mapped the cost of a product manufactured using a smart factory during the design phase.

The goal of this research study is to develop an interactive approach, in the form of an algorithm, to model and evaluate the production costs of a product in the design phase. The objective is to provide the design team with information on the behaviour of production costs as a function of predetermined technical solutions. Many factors can influence production costs, such as the architecture of the product, the production volume per year, the mechanical linkages, the materials or even the geometric shapes of the parts. This tool enables the identification of design and manufacturing improvements that will help reduce production costs.

The proposed algorithm was tested on a smart factory 4.0 installed in our organisation. The smart factory consists of digitally controlled machining units, a laser cutter and two 6-axis robots. This smart factory, which is shown in Fig. 1 is controlled by a manufacturing execution system; MES and a programmable logic controller; PLC. The product used for the test is a geometrically simple shock absorber composed of a spring, a stem and a body (see Fig. 2).

Here is an overview of the advantages of the proposed algorithm:

Fig. 1 Smart factory used for the experiment

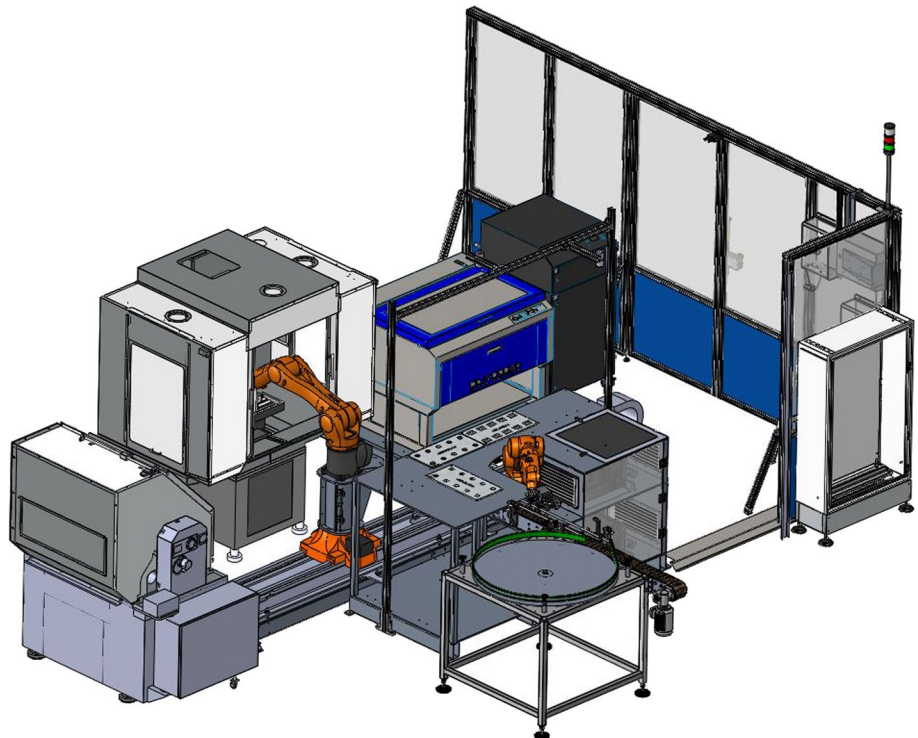
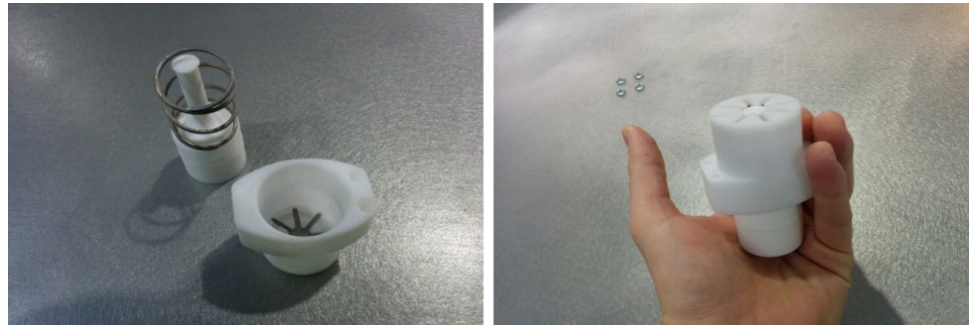

Fig. 2 The product used for the experiment



- Adapted to the industry 4.0 concept, notably data provision;
- Allows simultaneous optimisation of design and production processes;
- Allows comparison and optimisation of production costs in the design phase;
- Enables solutions to be adapted as a function of the desired economic model;
- Provides an optimal production plan;
- Allows relationships to be identified between the geometric characteristics of the product and the cost of production;
- Suggests recommended improvements based on recommendation mapping.

This article is divided into four sections. After the introduction (Sect. 1), the second section presents a literature review of the field of production cost modelling and optimisation. The third section is dedicated to the development of the algorithm for production cost modelling and optimisation. The fourth section describes a case study of a shock absorber. The results that were obtained confirmed the usefulness of the proposed algorithm. Finally, we will end with a conclusion and a presentation of potential future directions.

2 State of the art

Significant research effort has been dedicated to developing design methods and tools integrating manufacturing constraints (Design for manufacturing; DFM) and/or assembly constraints (Design for assembly; DFA). Many authors, including [10–13], have confirmed that estimating production costs in the design phase provides strategic data for design decisions.

In addition, industry 4.0, due to smart objects and digitised processing, enables the generation of a large quantity of important data that can be used during the design phase.

Interactive design is specially developed to support the data modeling in the design phase [14]. Our idea is to use

the data generated by digital processes to estimate the cost of production, identify causal links as a function of product features and optimise design in terms of costs and production times [15].

A literature review of engineering costs allowed us to derive two primary research themes. The first theme is based on the improvement of rapid and precise estimation techniques in the design phase [16]. In fact, a large number of methods have been developed to enable the estimation of production costs as a function of the quantity and kind of information available [17]. These methods are evaluated on the basis of the measured difference between the results from the approximate calculation and the real-life experiment. The methods can be divided into four families: intuitive, analogue, parametric and analytic [18]. Intuitive means that the cost is calculated based on personal knowledge and expertise. Analogue means that the cost is calculated as a function of statistical relationships between the characteristics and costs of previous products. Parametric means that the cost is calculated as a function of the geometry and/or the parameters characterising the product and the production process (cost driver). Analytic means that the cost is calculated by breaking down the work to be performed into basic tasks [19]. These methods differ in terms of the effort required for their use, the accuracy of the results, the objectivity of the results, the reproducibility of the results and the quantity of data needed to perform the calculation [20]. Intuitive methods such as the case-based reasoning method are recommended for determining costs in the overall production planning phase. Analogue and parametric methods such as regression methods (linear, nonlinear, multiple, etc.) are useful in the design phase. However, for the detailed or final design, analytic methods such as the activity-based costing method, feature-based cost estimation and others are used to calculate costs [21].

The second theme includes methods for optimising production costs. Production costs can be broken down into three cost elements: raw material costs, machining costs and assembly costs [22]. The optimisation methods, as a function of the cost element that they are designed to optimise, can also be divided into three categories. The first category

includes methods that aim to optimise the costs of the raw materials, which depend on the topology and shape of the product. Two general approaches can be used to optimise the topology, the weight and the shape of the product [23]. In the first case, any change to the initial design shape is left to the designer's intuition. In the second approach, the optimisation is based on software programs that perform a finite element analysis. In this case, the programs extract material from areas of the part that are under the least mechanical strain. Thus, these methods help reduce the raw materials costs needed, but, as a consequence, generate additional manufacturing costs. The second category includes methods that optimise machining costs. These methods determine the optimal values and machining parameters such as cutting speed, feed rate, machining trajectories, etc. When these parameters can be expressed quantitatively, optimisation techniques such as genetic algorithms or cumulative networks are used to optimise manufacturing costs [19]. The third category includes methods that optimise assembly costs, which can account for up to 40% of production costs [24]. These methods help reduce the number of assembled pieces, select the most appropriate assembly method (manual, automated or robotic) and optimise the assembly process (assembly sequences, correct orientation of components, etc.) [25].

From this analysis of the state of the art of methods for estimating and optimising production costs, two conclusions can be drawn:

First: estimation methods provide overall estimates, but cannot establish casual links to the design parameters

(dimension, shape, etc.) and the manufacturing parameters (cutting speed, feed rate, etc.) of the product. However, formalising this causality allows, first, identification of the best decisions, and second, their integration with the objective of optimising the design of industrial products while maintaining the same level of functionality.

Second: the three categories of optimisation methods listed above are specific solely to the cost aspect in the majority of cases. Each method considers and optimises only those parameters that contribute to this cost. Thus, one could synthesise and construct casual links between each cost element and the parameters that contribute to this cost.

Starting from these two points, a new interactive approach to modelling and optimising overall production costs, based on an iterative algorithm is formalised. At each iteration, the algorithm optimises one element of the production cost while retaining its functionalities, using one of the causal links derived from the literature review of existing optimisation methods. The details of the approach are discussed in the following section.

3 The interactive approach developed

The algorithm for modelling and optimising production costs is organised into four iterative steps. Figure 3 shows the different steps of the proposed algorithm.

The first step consists of extracting the machining features or machining operations using the geometric and topological information contained in three-dimensional model; 3D

Fig. 3 Steps of the algorithm for modelling and optimising production costs

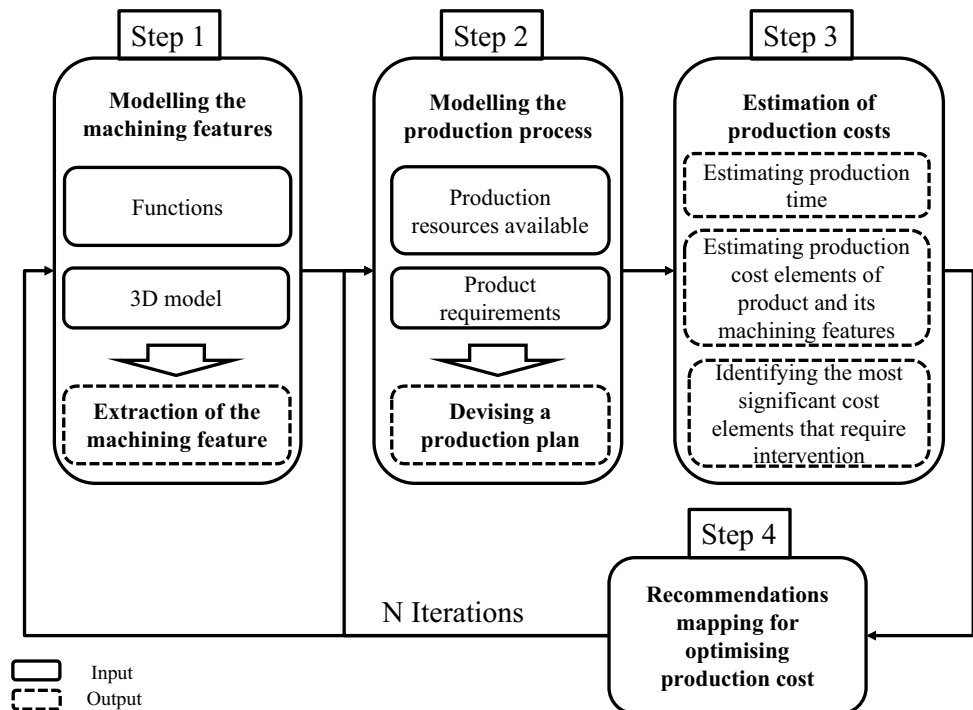

model. This introduces the scale of these features. In the second step, a production plan is devised for the machining features as a function of product requirements (production volume per year; p , surface finishing, etc.) as well as the available production resources (the type and number of machines, the type of cutting tools, etc.). The third phase consists of breaking down and evaluating the cost elements involved in the manufacturing process for the machining features (hole, step, etc.), such as the cost of the raw material used or the maintenance costs for the installations, as well as those involved directly in the production process for the product. This breakdown enables identification of the most significant cost elements. The fourth step allows partial rethinking of the product with the help of the recommendations, primarily by targeting the most significant cost elements. Below, we will describe each step of the proposed algorithm.

3.1 Modelling the machining features (step 1)

A machining feature has been defined by [16] as a geometric form and a collection of specifications for which there exists at least one machining process. The process is partly independent of the machining process for the other features of the part.

The objective of this first step is to extract the machining features using the geometric and topological information contained in a 3D model. The advantage of this representation is the ability to model all types of geometry and the accuracy with which the costs can be estimated during the design phase.

Figure 4 shows a set of standard machining features that are grouped into four classes [22]. Class 1 includes rotational features machined by using a turning process. Class 2 consists of prismatic features machined by face, slab, or end-milling operations. Class 3 includes slab features machined by end milling only. Finally, Class 4 contains a revolving feature (i.e., hole) machined by a drilling operation.

Figure 5 shows an example of modelling a part, one machining feature. In fact, three machining features are needed to transform the part from its raw form to its final form. The three features are step, step and groove.

3.2 Modelling the production process and devising a production plan (step2)

Planning the production process is a complex task that depends on multiple parameters, such as the material, the geometric characteristics of the product, production volume per year, the quality, the tolerance and the precision, etc. [11, 19, 26–29]. Our objective, at this stage, is to determine and create a structure for a production process (machining

Fig. 4 A set of standard machining features [22]

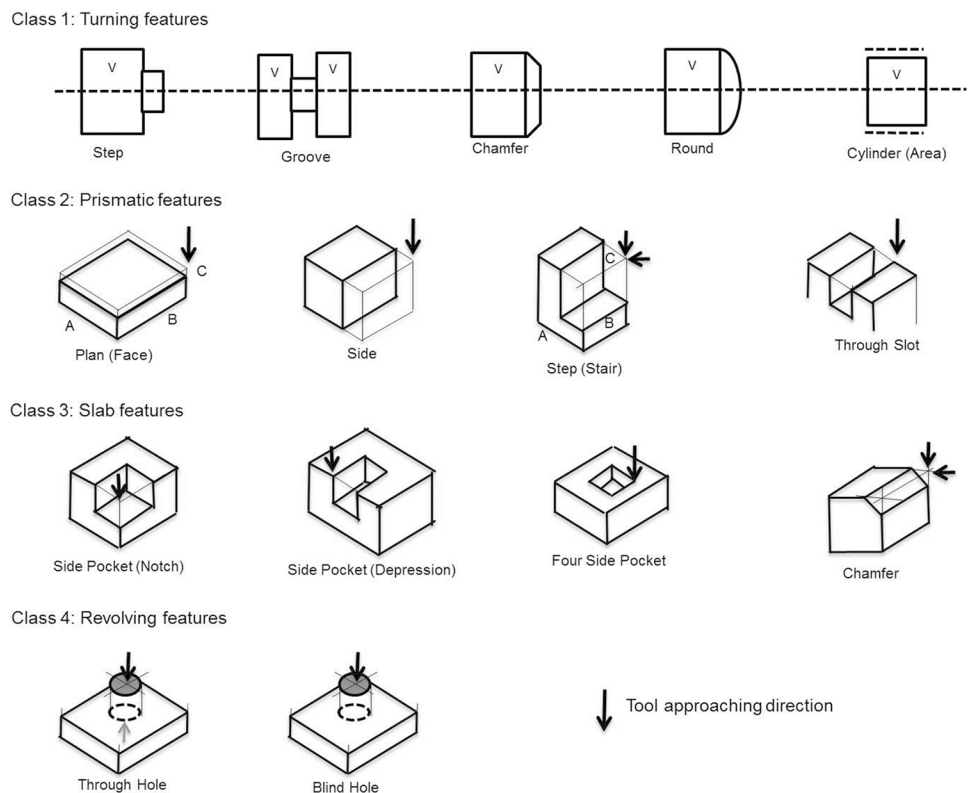

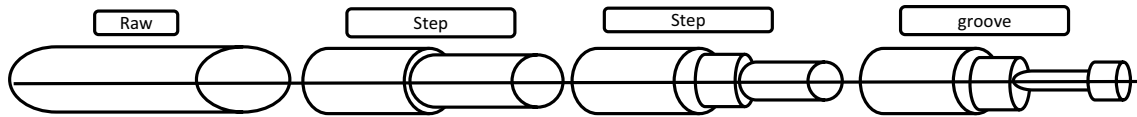
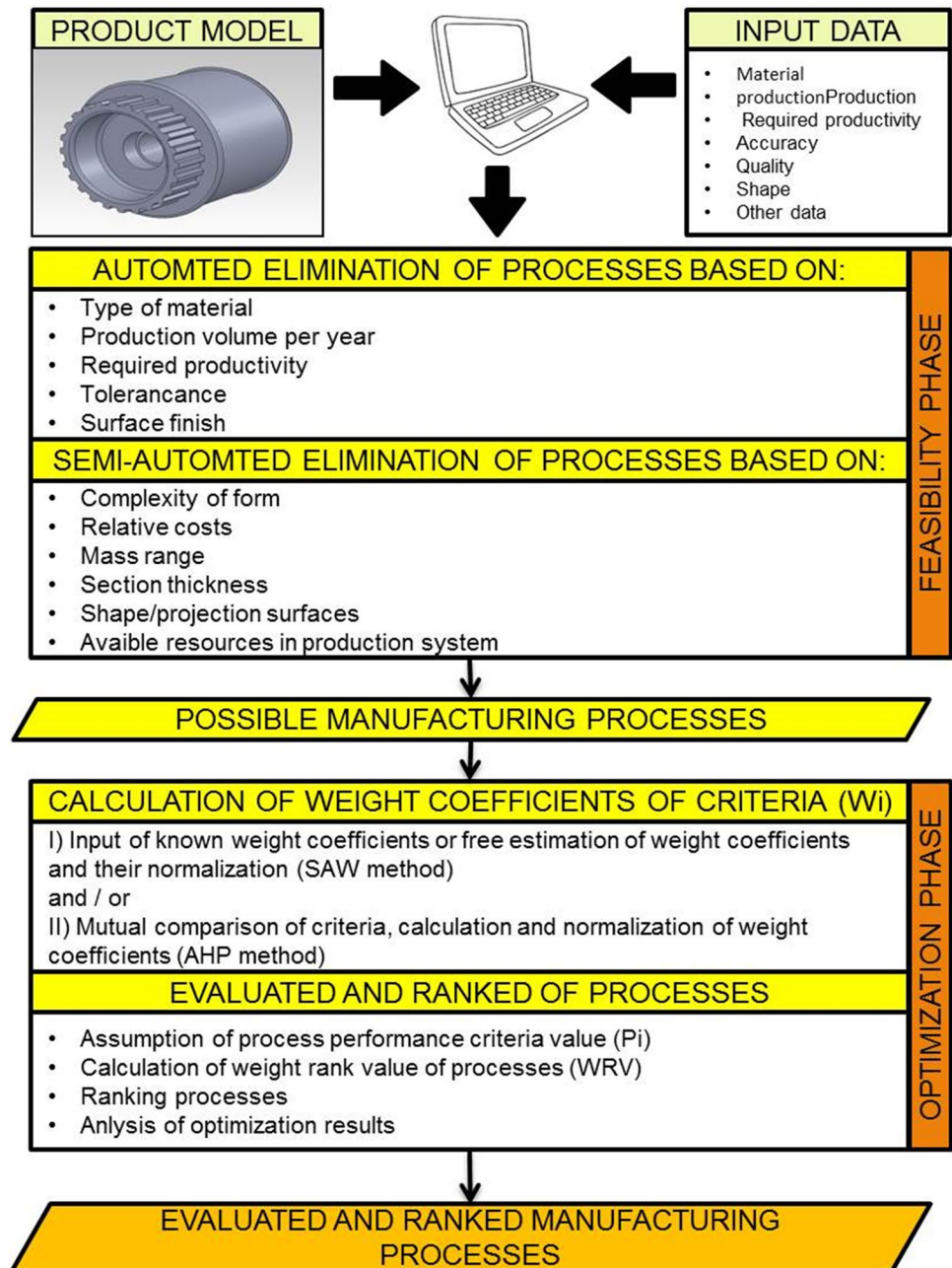

Fig. 5 Extraction of the machining features from 3D model

Fig. 6 Methodology for the multi-criteria selection of production processes [19]



ranges, assembly ranges, transfer ranges, etc.) as a function of available resources and methods (machines, robots, tools, etc.) and product specifications (production volume per year, surface finishing, precision, etc.) during the design phase.

In this work, we used the methodology proposed by [19] to select the most appropriate manufacturing processes for products at the conceptual design phase (see Fig. 6). This methodology begins, first of all, with the mapping of the

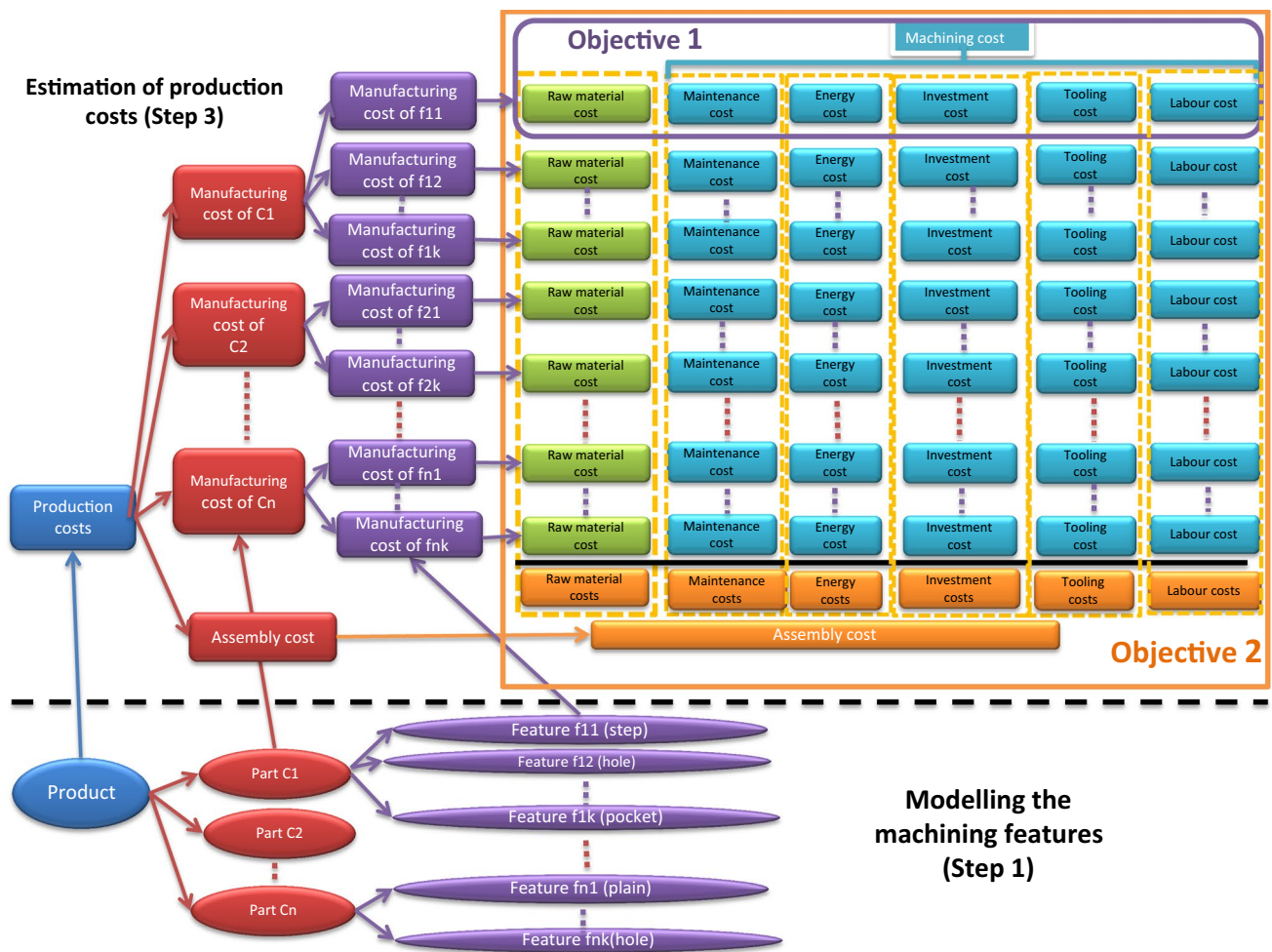

Fig. 7 Breakdown of the production costs

design and manufacturing requirements and constraints for the product according to 10 criteria such as raw materials, production volume per year, productivity, dimensional accuracy, surface finishing, etc. Then, it eliminates all of the manufacturing processes that do not fulfil these criteria. Finally, a multi-criteria evaluation and a ranking of the feasible manufacturing processes are performed on the basis of five criteria: manufacturing cycle time, process flexibility of the processes, raw material utilization (% wasted), quality and operating costs.

At the end of this stage, the suitable manufacturing procedures, the machines involved, the tools to be used and the skills necessary for guiding the production will have been determined.

3.3 Estimation of production costs (step 3)

For this step, we perform a specific breakdown to estimate a production cost that reflects reality. First of all, the product is

broken down into it's a set of parts; the total cost of production represents a sum of the production costs of all of the parts, as well as the cost of their assembly. Each part is, in its turn, broken down into a collection of machining features, for which a cost is determined. The cost of each machining feature (step, pocket, etc.) is obtained by adding up all of the cost elements that it comprises, such as labour cost, cost of equipment used, energy consumed cost, raw material cost, cutting tools cost and maintenance costs. Figure 7 shows the breakdown of the production costs into cost elements (step 3 of the algorithm).

The objective of this step, essentially, consists first of all (objective 1) of breaking down the manufacturing costs of each machining feature into cost elements, and then evaluating each cost element. The cost elements considered are labour cost, investment cost, energy cost, raw material cost, cutting tools cost and maintenance cost. Next (objective 2), the cost elements for production of the product are evaluated. The cost elements for production of the product considered are, in addition to the manufacturing costs for the

machining feature, the cost of assembly. These two breakdowns (features and product) will help designers identify the most significant cost elements that require improvement.

Finally, an importance factor is proposed to prioritise the machining feature to be improved.

3.3.1 Methods for calculating production costs

Calculating production costs is primarily based on machine usage time and the cost of the raw material [16]. Thus, we describe here algorithms for calculating production time and formulas for calculating the production cost elements.

3.3.1.1 Estimating production time The production time for product t_p is expressed as:

$$t_p = t_M + t_{ass}$$

where t_{ass} is the total time for assembly operations. t_M is the manufacturing time (turning, milling and laser machining). The manufacturing time of the product is expressed as:

$$t_M = \sum_{c=1}^{N_c} tc_c$$

where N_c indicates the number of product parts, tc_c is the manufacturing time for part C , which is expressed as:

$$tc_c = \sum_{f=1}^{N_{cf}} t_{cf}$$

where N_{cf} is the number of machining features for part C and t_{cf} is the manufacturing time of machining feature f of part C . The manufacturing time is composed of installation time, operational time and non-operational time [16, 22]. The manufacturing time t_{cf} for feature f of part C is expressed as:

$$t_{cf} = t_{op_{cf}} + t_{nop_{cf}} + t_{su_{cf}}$$

The different formulas for calculating production time are summarised in Table 1.

3.3.1.2 Estimating manufacturing cost elements (objective 1) After estimating the time needed for manufacturing machining features, we now turn our attention to how manufacturing cost elements are evaluated. In this article, the manufacturing cost of a machining feature is broken down into machining costs and the cost of the raw material. The machining cost is broken down into labour costs, investment costs, energy costs, tooling costs and maintenance costs. The manufacturing cost for a machining feature f of part C is expressed as:

$$C_{cf} = C_{in_{cf}} + C_{l_{cf}} + C_{R_{cf}} + C_{E_{cf}} + C_{M_{cf}} + C_{t_{cf}}$$

The formulas for calculating each cost element are provided in Table 2.

3.3.1.3 Estimating production cost elements (objective 2) The production cost of a product is broken down into manufacturing costs and assembly costs. It is expressed, maintaining the same breakdown of machining features into cost elements, as:

$$C_p = C_{in_p} + C_l + C_{R_p} + C_{E_p} + C_{M_p} + C_{t_p} + C_{ass}$$

Table 3 summarises the expressions of the production cost elements.

3.3.2 Ranking machining features by cost (importance factor)

To rank the impact of different machining features on the production cost of a product, we suggest the use of an importance factor denoted as I_{cf} . This importance factor, for machining feature f of a given part C , can be interpreted as the ratio of the manufacturing costs involved in its manufacturing on the total manufacturing cost for the product. It is expressed as:

$$I_{cf} = \frac{C_{cf}}{C_M}$$

The goal of this ranking is to identify the most expensive machining feature(s) (the machining features that have the greatest effect on the manufacturing costs of the product). Essentially, to significantly reduce the manufacturing costs of the product, priority must be given to interventions that target these most expensive machining features without compromising their functionalities.

3.4 Feedback loop: recommendations for optimising production costs

The objective of this step is to suggest design and manufacturing solutions, at each iteration, to reduce the production cost of the product. To do this, the designer must consider three points at each iteration. First, the designer chooses the level at which to intervene: the level of the product, or the level of the most expensive machining feature. Second, as a function of the results from the preceding step, the designer identifies the most significant cost element(s) (that require(s) improvement) at the level chosen in the preceding point (if the product, the designer will identify the most significant cost elements involved in the production of the product; if the feature, the most significant costs involved in the manufacturing of this feature). Third, the designer will change the design and/or manufacturing parameters according to

Table 1 Formulas for calculating production time

Production time component	Mathematical formula	Nomenclature	References
t_{ass} total time for assembly operations of a part C	$t_{\text{ass}_c} = (T_p + T_I) + \frac{m(i)b(i)+b(i)m(i+1)}{v_r}$	T_p is the time for picking up a part upon arrival T_I is the time for inserting a part upon arrival $m(i)$ is the magazine pickup location of the i th assembly sequence $b(i)$ is the placement location of the i th assembly sequence v_r is the velocity of the robot (average speed)	[24]
Set-up time per feature $t_{\text{su}_{cf}}$	$t_{\text{su}_p} = \frac{\sum_i t_{ai} + \sum_j \sum_i t_{bij}}{Q}$ $t_{\text{su}_{cf}} = \frac{t_{\text{su}_p}}{N_f}$ $N_f = \sum_{c=1}^{N_c} N_{cf}$	t_{su_p} is the setup time per machined product Q is the batch size during machining process t_{ai} is the basic setup time of i th machine used t_{bij} is the setup time of j th tool used for machine i N_f is the number of machining features for product (all parts)	[16, 22, 30]
Operational time per feature $t_{\text{op}_{cf}}$ Turning, milling and drilling	$t_{\text{op}_{cf}} = t_r + t_f + \sum_{j=1}^{kf} t_{\text{adj}_j}$ $t_r = \frac{V_{rm}}{\text{MRR}}$ $t_f = \frac{A_f}{R_m}$	t_r is the rough cutting time t_f is the finish cutting time k_f is the number of tools used to manufacture a feature f t_{adj_j} is the approach time of tool j V_{rm} is the volume of removed material during initial cutting expressed in (inches ³ ;in ³) MRR is the material removal rate expressed in (in ³ /minutes; min) A_f is the finish cutting area expressed in in ² R_m is the surface generation rate for milling process expressed in (in ² /min)	[16, 22, 30]
Laser	$t_{\text{op}_{cf}} = \frac{V_{rm}}{\text{MRR}_L}$ $\text{MRR}_L = \rho \frac{\pi d^2 z_t}{4t_d}$	MRR_L is the laser material removal rate d is the laser beam diameter z_t is the depth of machined cavity t_d is the total time of interaction for N_d pulses ρ is the density of material	[31]
Non-operational time per feature $t_{\text{nop}_{cf}}$	$t_{\text{nop}_{cf}} = \frac{t_{lt}}{N_{cf}} + \delta_{cf} t_{lt} + t_{et} + t_{al}$	t_{lt} is the loading time of part contains the feature f δ_{cf} is a Boolean value that is 1 if feature f of part C requires a loading and unloading, 0 if not t_{et} is the total tool engaging time t_{al} is the allowances of machine and operator	[16]

the cost elements identified. To determine the design and/or manufacturing parameters that must be modified, we have suggested a list of recommendations that can offer solutions regarding design and manufacturing. Figure 8 shows the

optimisation process and the list of different recommendations proposed in this article.

Each recommendation represents a collection of parameters, associated with both design and production, that can

Table 2 Formulas for calculating the manufacturing cost for a machining feature

Cost elements for manufacturing machining feature f of part C	Mathematical formula	Nomenclature	References
The total investment cost of single feature $C_{in_{cf}}$	$C_{in_i} = C_{ma_i} + C_{ins_i} + \frac{C_{div}}{n}$ $C_{in_p} = \frac{C_{m_i}}{p} \left(\frac{1}{t_{dl_i}} + \frac{\tau_{in}}{2} \right)$ $C_{in_{cf}} = C_{in_p} \frac{t_{cf}}{t_{mi}}$ $t_{mi} = \sum_{c=1}^{Nc} \sum_{f=1}^{Nc_f} \delta_{icf} t_{cf}$ $C_{in_{cf}} = C_{in_{i_j}} \text{ (each feature is only manufactured by a single machine)}$	<p>C_{in_i} is the cost of investment in machine i</p> <p>C_{ma_i} is the cost of the machine i</p> <p>C_{ins_i} is the installation cost of the machine i</p> <p>C_{div} cost of pieces used throughout the lifespan of the installation</p> <p>n is the number of machines needed to produce the product</p> <p>p is the production volume per year</p> <p>$C_{in_{i_j}}$ is the total investment cost of machine i by product p</p> <p>τ_{in} is the annual rate of interest</p> <p>t_{dl_i} is the depreciable life of machine i (years)</p> <p>t_{mi} is the total machining time for the product produced by machine i</p> <p>δ_{icf} is a Boolean value that is 1 if feature f of component C is performed by machine i, 0 if not</p>	[32]
Labour cost of single feature $C_{l_{cf}}$	$C_{l_p} = \frac{\sum_{i=1}^n CS_i N_i N_{m_i}}{p}$ $C_{l_{cf}} = C_{l_p} \frac{t_{cf}}{t_M}$	<p>CS_i is the annual salary of the manufacturing personnel working on machine i</p> <p>N_i is the number of personnel needed to staff the machine i</p> <p>N_{m_i} is the number of machine i's needed to fulfil the production volume p</p>	[33]
Raw material of single feature Cost $C_{R_{cf}}$	$C_{R_{cf}} = P_{R_r} \left(n_{R_{rc}} + \frac{n_{R_{rc}} - \sum_{f=1}^{N_{cf}} n_{R_{rc_{cf}}}}{N_{cf}} \right) + \frac{C_{cf}}{Q N_{cf}}$ $n_{R_r} = 1.1 \quad 1.2 V_r \rho_r$	<p>P_{R_r} is the unit price for raw material r</p> <p>$n_{R_{rc}}$ is the quantity of raw material r used for part C</p> <p>ρ_r is the volumetric mass of raw material r</p> <p>V_r is the volume of raw material r</p> <p>$n_{R_{rc_{cf}}}$ is the quantity of the raw material r eliminated during the production of feature f of part C</p>	[20]
Energy cost of single feature $C_{E_{cf}}$	$C_{E_{cf}} = P_{a_i} t_{cf} C_{kh_i}$	<p>C_{sF} is the cost of the fixation system</p> <p>P_{a_i} is the maximum power absorbed by machine i used to manufacture feature f</p> <p>C_{kh_i} is the unit price in kilowatt hours of machine i</p>	[34]
Maintenance cost of single feature $C_{M_{cf}}$	$C_{M_{cf}} = C_{M_i} t_{cf}$	<p>C_{M_i} is the maintenance hourly cost of the machine i</p>	[33]
Tooling cost of single feature $C_{t_{cf}}$	$C_{t_{cf}} = \sum_{j=1}^{kf} \left(C_{t_{jcf}} t_{op_{jcf}} \right)$ $t_{op_{cf}} = \sum_{j=1}^{kf} t_{op_{jcf}}$ $C_{t_{jcf}} = \frac{C_{uj_{cf}}}{T_{jcf}}$	<p>j_{cf} indicates cutting tool j used to manufacture machining feature f of part C</p> <p>$t_{op_{jcf}}$ is the operational time for tool j_{cf}</p> <p>$C_{t_{jcf}}$ is the hourly cost of the cutting tool j_{cf}</p> <p>$C_{uj_{cf}}$ cost of cutting tool j_{cf}</p> <p>T_{jcf} is the tool life in hour</p>	[32]

Table 3 Formulas for calculating the production cost of a product

Production cost elements of a product	Mathematical formula	Nomenclature
Investment cost C_{in_p}	$C_{in_p} = \sum_{c=1}^{N_c} \sum_{f=1}^{N_{cf}} C_{in_{cf}}$	
Labour Cost C_{l_p}	$C_{l_p} = \sum_{c=1}^{N_c} \sum_{f=1}^{N_{cf}} C_{l_{cf}}$	
Raw material cost C_{R_p}	$C_{R_p} = \sum_{c=1}^{N_c} \sum_{f=1}^{N_{cf}} C_{R_{cf}}$	
Energy cost C_{E_p}	$C_{E_p} = \sum_{c=1}^{N_c} \sum_{f=1}^{N_{cf}} C_{E_{cf}}$	
Maintenance cost C_{M_p}	$C_{M_p} = \sum_{c=1}^{N_c} \sum_{f=1}^{N_{cf}} C_{M_{cf}}$	
Tooling cost C_{t_p}	$C_{t_p} = \sum_{c=1}^{N_c} \sum_{f=1}^{N_{cf}} C_{t_{p,cf}}$	
Assembly cost C_{ass}	$C_{ass} = \sum_{c=1}^{N_a} t_{ass_c} C_a$ [25]	N_a is the number of parts c to be assembled C_a is the assembly unit cost

be considered to contribute to one element of the production costs. For example, in aeronautic parts, the cost of the material is generally the most significant cost with regards to the production cost [35]. This is due to the special types of materials (composites, carbides, etc.) used in this field. To optimise the production cost of these parts, the recommendation list indicates that, as a matter of priority, we should consider modifying the type of material, the dimensions of the pieces, the shape and the topology, etc. Because these parameters are generally the most likely contributors to the cost of the material. This explains why companies that fabricate aeronautic parts are in constant search of new materials, shape optimisation, etc., [23].

The suggested list of recommendations is an expanded literature review of optimisation methods. The choice between these recommendations is potentially the most complex part. For the designer, the first challenge is to evaluate the technical feasibility of the implementation of these different recommendations (design and manufacturing parameters) while maintaining the same level of functionalities of the product. For example, it may be impossible to change the material or the shape of the product or a given machining feature. Based on the results of this technical analysis, the number of recommendations available to a designer may be reduced. If several solutions (recommendations) exist, they should be integrated into the initial simulation algorithm to evaluate their impact on the production cost of the product.

4 Testing and analysis

In this section, a geometrically simple shock absorber has been selected to test the proposed algorithm. Given that this algorithm is iterative, and that each iteration of optimisation can be carried out the product level or at the level of a machining feature, we performed two tests that each address one of the two levels: product (shock absorber) and most expensive machining feature of shock absorber. In addition, a final test was performed, still on the shock absorber, to show the added value of using the recommendation list to choose the design and production parameters to improve.

The shock absorber, shown in Fig. 9, is made up of three parts, including a spring (part 3), a cylindrical rod (part 1) and a body in the shape of a prism (part 2) before machining. Only the part 1 and the part 2 are fabricated, the part 3 is purchased.

The smart factory used to manufacture and assemble this shock absorber is composed of a digital lathe, a 3-axis machining centre, a laser cutter and an accumulation table (Fig. 10a). Two 6-axis robots, one of which is rail-mounted, handle loading, unloading, transfer and assembly. This smart factory, which is shown in Fig. 1 and 10, is guided by a programmable logic controller.

As indicated in Chapter 3, the algorithm is based on four iterative steps.

The first step is to identify and extract the machining features of the different parts of the product. For part 1 (the cylindrical part), there are three features: step, step and groove (Fig. 5). For part 2 (the prism-shaped) there are five features: plain, stair ($\times 2$), pocket, hole and a star-shaped feature made with a laser cutter. The same material is used for these two parts: polyvinyl chloride; PVC. The cylindrical part is 1.378 in. in diameter and 3.1496 in. in length, and the prism-shaped part is 2.3622 in. \times 1.7717 in. \times 1.5748 in.

In the second step, a production plan is integrated into the algorithm. It states the timeline for all of the phases of manufacturing, assembly and transfer. The starting point is placing the raw parts in an area where the camera can recognise their positions (coordinates x and y) and their shapes (cylindrical or rectangular) (Fig. 10a). The destination point corresponds to delivery of the completed shock absorber to the accumulation table (Fig. 10c). The intermediate points correspond to the machining steps, the movements of the robots, the opening or closing of the machines' security doors and transfer of the parts between the machines and the temporary storage spaces (in progress) (Fig. 10b).

In the third step, the algorithm first calculates the manufacturing cost elements (raw material cost, maintenance cost, etc.) of each feature (step, plain, etc.) using the formulas in Table 2, as well as the importance factor (I_{cf}) of each machining feature. Then, it calculates

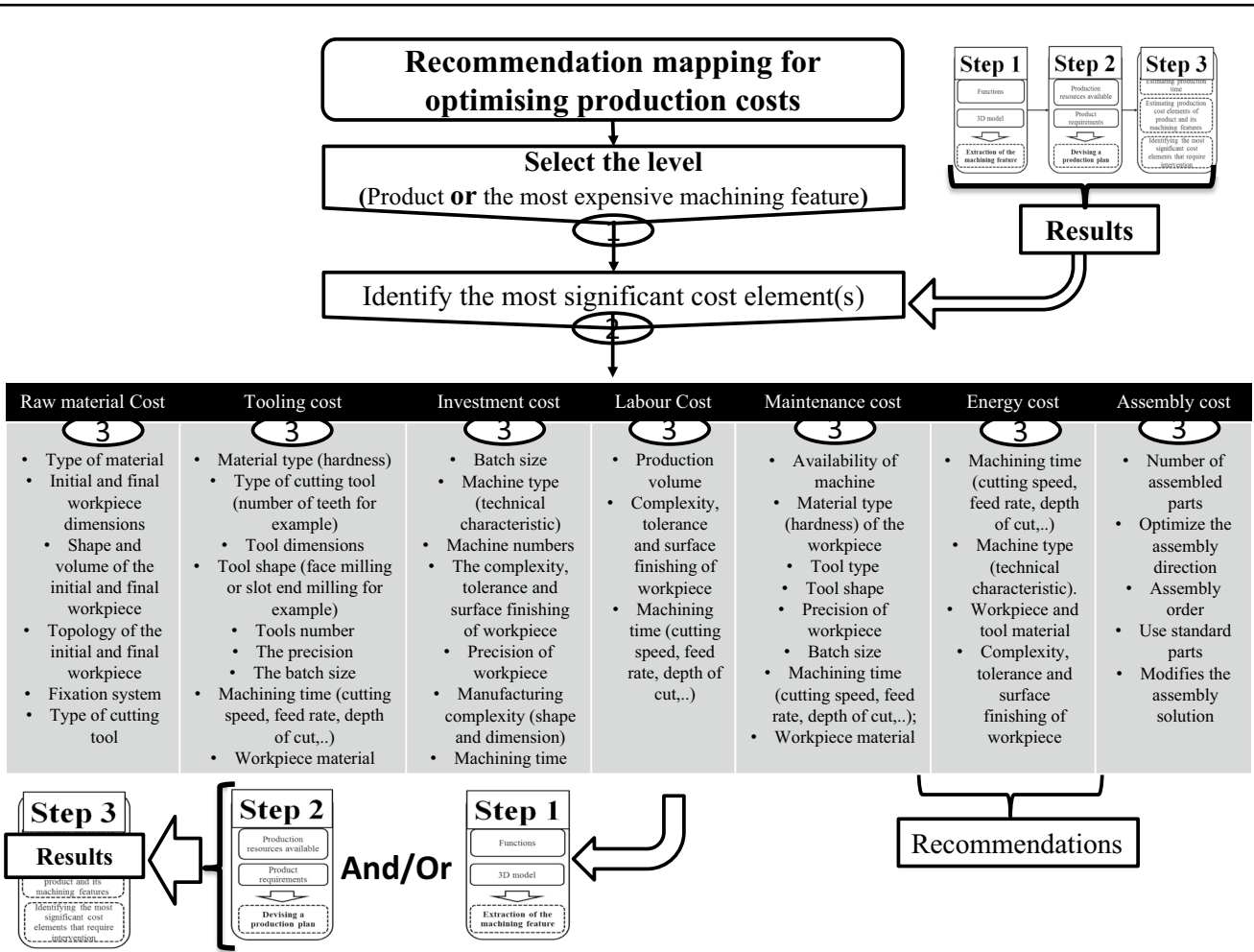
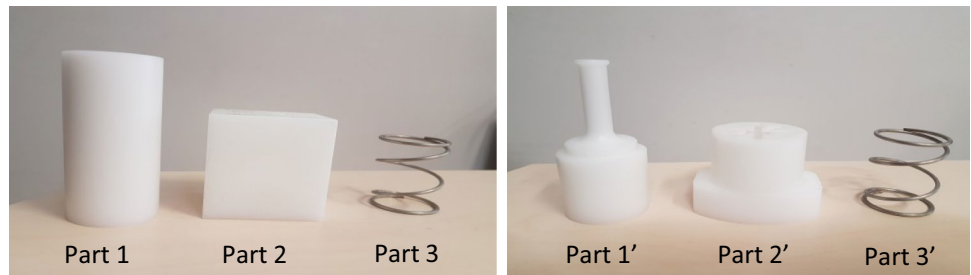

Fig. 8 Recommendations mapping

Fig. 9 Raw and machined parts of shock absorber



the overall production cost elements (raw material cost, assembly costs, etc.) of the shock absorber and ranks them in decreasing order (the formulas in Table 3). The data that are entered into the algorithm are summarised in Table 4. These data represent the different production parameters needed for the simulation.

The fourth step involves optimisation of product as a function of production cost. It can be divided into two parts: optimisation at the product level and optimisation at the level of the machining features.

4.1 Optimisation at the product level

Optimisation at the product level targets the most significant cost elements of the shock absorber. Figure 11 shows the breakdown of production costs for the shock absorber. Notably, 1/3 of the overall cost is accounted for by labour and 1/3 by the cost of the raw material. In short, the most significant cost elements are the labour costs and the raw material costs. These results seem consistent with the results published by [20, 22].

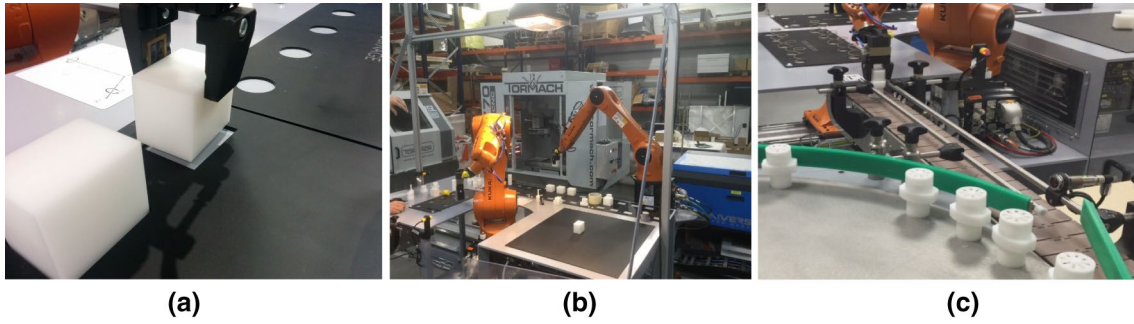

Fig. 10 Production steps of the shock absorber on the smart factory

Table 4 Machine, cutting tool and part material data required for simulation

Machine	Cutting tool	Material
Machine type	Cutting tool type	Material type
Number of machines	Number of cutting tool	Material dimensions
Horse power of machine	Tool dimensions	Material shapes
Setup time of machine	Tool material	Material density
Kilowatt hours	Setup time tool	Material unit price
Engaging time	Tool cost	Chemical characteristics (solidification and vaporization temperature, conductivity...)
Power, frequency and duration of a pulse (laser cutting)	Tool lifetime	Surface generation rate for milling and drilling processes
Machine cost		
Batch size production volume per year		

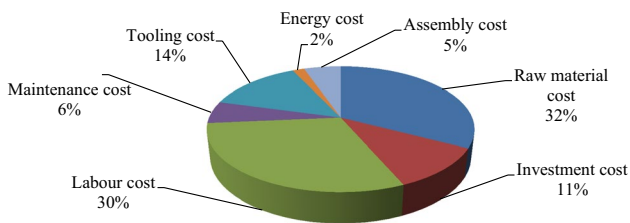

Fig. 11 Breakdown of production costs for the shock absorber

Typically, methods engineers (industries, manufacturers) improve the production process by optimising, for example, the manufacturing operation schedule or the machining parameters. However, the results obtained here show that, to optimise the overall production cost of the shock absorber, it would be more useful to address the cost of the labour and the cost of the raw material. This simulation information, generated by the algorithm, will help designers perform an initial optimisation of the original product. This initial optimisation consists of using the list of recommendations (Fig. 8) to identify the design parameters and/or manufacturing parameters that may require modification. In this first part of the test, we considered two design parameters. The

first parameter concerns the cost of the labour, which is the production volume per year. The second parameter concerns the material cost, which is the material type.

After verifying the feasibility of these parameters, a comparative analysis of the total production costs of different scenarios was performed. The results are presented in Table 5. The best result was obtained by implementing solution 4. This improvement decreased the manufacturing cost of the shock absorber by 18% compared to the initial case.

In addition, for a proper understanding of the effect of an increase in production volume on total production costs per product and its cost elements, a comparative analysis has been carried out. Figure 12 illustrates a significant variation in labour costs as a function of p compared to other cost elements.

4.2 Optimisation at the machining feature level

Optimisation at the machining feature level consists of improving the most significant machining feature cost elements that have the greatest effect on the manufacturing cost of the product. To do this, we must first determine the most expensive machining feature. The dimensions, the machining volume for rough cut, the machining area for finish cut,

Table 5 Product manufacturing cost for different solutions

Initial case (production volume per year = 5000) (M0:PVC)	Production volume per year; p				Material type	
	Solution 1 p=6000	Solution 2 p=7000	Solution 3 p=8000	Solution 4 p=9000	Solution 5 M=M1	Solution 5 M=M2
C_p (euros)	12.599	11.742	11.130	10.671	10.314	12.143
Optimisation % compared to the initial case	$\frac{C_{p0}-C_{pi}}{C_{p0}} 100\%$					
	6.8	11.66	15.30	18.13	3.62	7.20

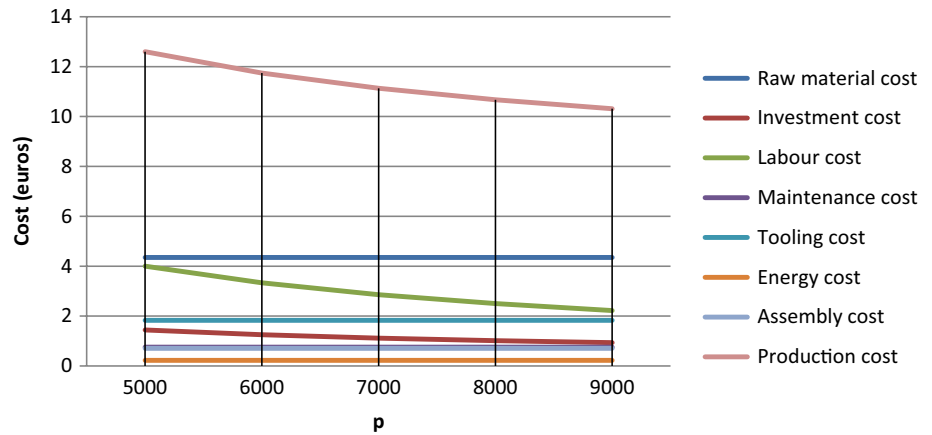
Fig. 12 Behaviour of total production costs per product and its cost elements as a function of p**Table 6** Feature dimensions, manufacturing time and manufacturing cost for the shock absorber

Features	N°	Dimensions			V_{rm}	A_f	t_r	t_f	$T_{nop_{cf}}$	t_{cf}	% I_{cf}
f11 (step)	1	1,37	1,18	1,77	0,70	6,96	0,38	0,28	0,51	1,23	8.6
f12(step)	1	1,18	0,47	1,57	1,45	4,18	0,80	0,17	0,51	1,53	11.02
f13(Groove)	1	0,47	0,39	1,50	0,08	19,76	0,04	0,81	0,51	1,42	10.10
f21(Plain)	1	2,36	1,77	0,20	0,82	4,19	0,21	0,43	0,35	1,02	9.31
f22(Stair)	2	0,39	2,37	0,67	0,62	2,51	0,24	0,28	0,35	1,81	13.48
f23(Pocket)	1	1,57	1,10	0,39	2,47	3,84	0,47	0,22	0,35	1,07	9.74
f24(Hole)	1	1,37	1,78	x	2,64	9,16	1,81	0,74	0,35	2,92	25.42
f25(Star)	1	10	3	2	0,49	Surface	0,11	0,5	1,27	1,98	12.34

the machining time and the cost of fabricating each feature were estimated using the equations developed in part III. The results are shown in Table 6.

These results allow us, first of all, to rank the impact of different machining features on the manufacturing cost of the product. We thus have the importance factor I_{cf} of each machining feature f of part C:

$$I_{24} > I_{22} > I_{12} > I_{13} > I_{11} > I_{23} > I_{21} > I_{25}$$

Within this framework, the recommendations for design and manufacturing should focus first on machining feature I_{24} . This accounts for as much as 25% of the manufacturing costs of the shock absorber ($I_{24} = \frac{2.622}{10.314} = 25.42\%$).

The next step is to identify the most significant cost elements of machining feature f_{24} . Figure 13 shows the breakdown of the manufacturing costs for machining feature f_{24} . The raw material cost represents the most significant cost for machining feature f_{24} . Thus, to optimise the manufacturing costs of this feature, one should first focus on the material used and/or its dimension. This information, derived from the proposed recommendations, will allow designers to direct their efforts toward finding a substitute material and/or a new dimension, while keeping in mind the desired functions and characteristics.

In this second part of the test, the proposed solution consisted of modifying the diameter of the hole from 1.37 to 0.98 in. (35 to 25 mm). This solution was suggested by

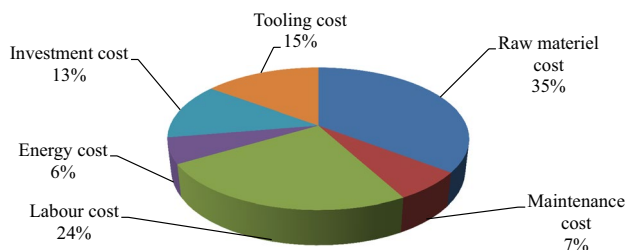

Fig. 13 Breakdown of the manufacturing costs for machining feature f_{24}

Table 7 Impact of the solution on the manufacturing cost of the f_{24} and product

	Machining feature f_{24} (Initial case) (d = 1.37 in.)	Solution (d = 0.98 in.)	Optimisation % compared to the initial case (%)
C_f (euros)	2,467	1246	49.5
C_p (euro)	10.314	9992	3.12

design engineers. The results are shown in Table 7. This solution decreased the manufacturing cost of the product by 3.12%, and the manufacturing cost of machining feature f_{24} by 49.5%, compared to the original shape.

4.3 Proof of the reliability of the recommendations mapping suggested in Fig. 8

In order to test the reliability and robustness of the suggested recommendations mapping (Fig. 8), we implemented the parameter (cutting speed) that had the least effect on the product cost elements identified earlier (labour and raw material) (Fig. 8). Then, we compared the variation in the production cost of the product generated by changing the cutting speed; cs ; and production volume p parameters. Note that the parameter of changing the production volume was derived from the suggested recommendation list (Table 7). The results from this comparison are shown in Table 8. There was a small change in the production cost when the cutting speed was changed, on the order of 0.1% compared to the original scenario. However, there was a significant

change in the case of the parameter selected from the suggested list of recommendations (p), on the order of 7% compared to the original scenario. This confirms the reliability of the proposed recommendation mapping in specific and the proposed algorithm in general.

5 Conclusion and perspectives

The algorithm proposed in this article establishes a framework for evaluating and optimising production costs in the design phase. The iterative interactive approach developed here enables designers to make technical modifications and make a dynamic assessment of how the production costs change (machining cost, cutting cost, assembly cost, etc.). This approach thus makes it possible to integrate knowledge from the production phase into the design phase.

The algorithm is organized in four steps allowing the product to evolve from its initial version to a version optimized according to production costs (machining, cutting and assembly). The first step consists in representing the product in the form of machining features, and determining their dimensional. The second step defines a production plan. This plan organizes and sets parameters for manufacturing operations according to the product requirements (production volume per year; p , surface finishing, etc.) and available production resources (the type and number of machines, the type of cutting tools, etc.). The third step consists of breaking down and evaluating the cost elements involved in the production process for the product, such as the cost of raw materials used or the costs of maintaining the installations, as well as those involved directly in the manufacturing process of the machining features (step, hole,...). This breakdown enables identification of the most significant cost elements. The last step offers designers recommendations, in terms of solutions, to be integrated into design and production in order to optimize production costs. If the first result is unsatisfactory, other iterations can be performed.

This algorithmic interactive approach is a novel tool for the dynamic simulation of production costs. It takes into account technical design solutions, as well as the production plan. For the designer, the challenge is to make the best

Table 8 Production cost of the product for different solutions

Initial case (production volume per year = 5000, cutting speed $C_s = 5,25$ in./mn)	Cutting speed cs (in./mn)			Production volume per year; p			
	Solution 1	Solution 2	Solution 3	Solution 4	Solution 5	Solution 6	Solution 7
	$C_s = 5.5$	$C_s = 5.75$	$C_s = 6$	$p = 6000$	$p = 7000$	$p = 8000$	$p = 9000$
C_p (euros)	12.587	12.570	12.555	11.742	11.130	10.671	10.314
Production cost % between the initial and new solution	0.095%	0.23%	0.35%	6.80%	11.67%	15.30%	18.14%

choice between the different recommended solutions, with the objective of decreasing the production costs.

The algorithm was tested for the production of a simply shaped shock absorber. To do this, we used a smart factory installed in our organisation. The algorithm was used to identify the most significant cost elements and to propose targeted solutions for optimising production costs. A single iteration of the algorithm resulted in a 18% reduction in production costs compared to the original product.

These results are encouraging and could be the focus of future studies. Approaches such as meta-heuristic methods (Genetic algorithms) could be used for multi-parameter optimisation.

References

1. Karre, H., Hammer, M., Kleindienst, M., Ramsauer, C.: Transition towards an Industry 4.0 State of the LeanLab at Graz University of Technology. *Procedia Manuf.* **9**, 206–213 (2017)
2. Synnes, E.L., Welo, T.: Enhancing integrative capabilities through lean product and process development. *Procedia CIRP* **54**, 221–226 (2016)
3. Yann-Guirec, M., Khaled, B., Améziane, A.: Life cycle cost through reliability. In: Zamojski, W., Mazurkiewicz, J., Sugier, J., Walkowiak, T., Kacprzyk, J. (eds.) *New results in dependability and computer systems*, pp. 523–530. Springer, Switzerland (2013)
4. Etienne, A., et al.: Cost engineering for variation management during the product and process development. *Int. J. Interact. Des. Manuf. IJIDeM* **11**(2), 289–300 (2017)
5. Audoux, K., Segonds, F., Kerbrat, O., Aoussat, A.: Toward a customized multicriterion tool for product evaluation in the early design phases: the CMDet methodology. *Int. J. Interact. Des. Manuf.* (2019). <https://doi.org/10.1007/s12008-019-00549-8>
6. Alsyouf, I., Al-Alami, A., Saidam, A.: Implementing product design development methodology for assessing and improving the performance of products. *Int. J. Interact. Des. Manuf. IJIDeM* **9**(3), 225–234 (2015)
7. Nadeau, J.-P., Fischer, X.: *Research in Interactive Design. Virtual, Interactive and Integrated Product Design and Manufacturing for Industrial Innovation*, vol. 3. Springer, Berlin (2011)
8. Kumar, U., Markeset, T.: Product support strategy: conventional versus functional products. *J. Qual. Maint. Eng.* **11**(1), 53–67 (2005)
9. Markeset, T., Kumar U.: R&M and risk-analysis tools in product design, to reduce life-cycle cost and improve attractiveness. In: 2001 Proceedings on Annual Reliability and Maintainability Symposium. International Symposium on Product Quality and Integrity (Cat. No. 01CH37179), pp. 116–122. Philadelphia, PA, USA, (2001)
10. Boothroyd, G., Radovanovic, P.: Estimating the cost of machined components during the conceptual design of a product. *CIRP Ann.* **38**(1), 157–160 (1989)
11. Boothroyd, G., Dewhurst, P., Knight, W.A., Dewhurst, P., Knight, W.A.: *Product Design for Manufacture and Assembly, Revised and Expanded*. CRC Press, Boca Raton (2001)
12. Evbuomwan, N.F.O., Sivaloganathan, S., Jebb, A.: Concurrent Materials and Manufacturing Process Selection in Design Function Deployment. *Concurr. Eng.* **3**(2), 135–144 (1995)
13. Feng, S.C., Song, E.Y.: Information modeling of conceptual process planning integrated with conceptual design. In: The 5th design for manufacturing conference, The 2000 ASME design engineering technical conferences, Baltimore, Maryland, Paper Number DETC00/DFM-14009, 10–13 September 2000
14. Segonds, F., Cohen, G., Véron, P., Peyceré, J.: PLM and early stages collaboration in interactive design, a case study in the glass industry. *Int. J. Interact. Des. Manuf. IJIDeM* **10**(2), 95–104 (2016)
15. Liu, J., Ma, Y.: A survey of manufacturing oriented topology optimization methods. *Adv. Eng. Softw.* **100**, 161–175 (2016)
16. Jung, J.-Y.: Manufacturing cost estimation for machined parts based on manufacturing features. *J. Intell. Manuf.* **13**(4), 227–238 (2002)
17. Elgh, F., Cederfeldt, M.: Concurrent cost estimation as a tool for enhanced producibility—system development and applicability for producibility studies. *Int. J. Prod. Econ.* **109**(1), 12–26 (2007)
18. Niazi, A., Dai, J.S., Balabani, S., Seneviratne, L.: Product cost estimation: technique classification and methodology review. *J. Manuf. Sci. Eng.* **128**(2), 563–575 (2005)
19. Lukic, D., Milosevic, M., Antic, A., Borojevic, S., Ficko, M.: Multi-criteria selection of manufacturing processes in the conceptual process planning. *Adv. Prod. Eng. Manag.* **12**(2), 151–162 (2017)
20. Molcho, G., Cristal, A., Shpitalni, M.: Part cost estimation at early design phase. *CIRP Ann.* **63**(1), 153–156 (2014)
21. Luki, D., Milošević, M., Borojevi, S.: Manufacturing cost estimation in the conceptual process planning. *Mach. Des.* **8**(3), 83–90 (2016)
22. Chang, K.-H.: *Product Manufacturing and Cost Estimating using CAD/CAE: The Computer Aided Engineering Design Series*. Academic Press, London (2013)
23. Griese, D., Namouz, E., Shankar, P., Summers, J. D., Mocko, G.: Application of a lightweight engineering tool: lazy parts analysis and redesign of a remote controlled car, pp. 839–847 (2011)
24. Li, R.-K., Hwang, C.-L.: A framework for automatic DFA system development. *Comput. Ind. Eng.* **22**(4), 403–413 (1992)
25. Shehab, E.: An intelligent knowledge based cost modelling system for innovative product development (2001)
26. Creese, R.: *Introduction to Manufacturing Processes and Materials*. CRC Press, Boca Raton (2017)
27. Giachetti, R.E.: A decision support system for material and manufacturing process selection. *J. Intell. Manuf.* **9**(3), 265–276 (1998)
28. Yu, J.-C., Krizan, S., Ishii, K.: Computer-aided design for manufacturing process selection. *J. Intell. Manuf.* **4**(3), 199–208 (1993)
29. Xu, X., Wang, L., Newman, S.T.: Computer-aided process planning—a critical review of recent developments and future trends. *Int. J. Comput. Integr. Manuf.* **24**(1), 1–31 (2011)
30. Orji, I.J., Wei, S.: Reducing total costs of machined parts through green manufacturing. *Int. J. Manuf. Technol. Manag.* **30**(5), 289–305 (2016)
31. Samant, A.: Laser machining of structural ceramics: computational and experimental (2019). (Online) https://trace.tennessee.edu/utk_graddiss/99/. Accessed 17 Jan 2019
32. Duverlie, P., Castelain, J.M.: Cost estimation during design step: parametric method versus case based reasoning method. *Int. J. Adv. Manuf. Technol.* **15**(12), 895–906 (1999)
33. Gao, Q., Lizarazo-Adarme, J., Paul, B.K., Haapala, K.R.: An economic and environmental assessment model for microchannel device manufacturing: part 2—Application. *J. Clean. Prod.* **120**, 146–156 (2016)

-
34. Dufloy, J.R., Kellens, K., Renaldi, Y., Guo, W.Dewulf: Critical comparison of methods to determine the energy input for discrete manufacturing processes. *CIRP Ann.* **61**(1), 63–66 (2012)
 35. Lwin, T., Lin, T., Lee, J.: Integrated approach for rotor blade manufacturing cost estimate. *Aircr. Eng. Aerosp. Technol.* **83**(4), 235–244 (2011)