



Science Arts & Métiers (SAM)

is an open access repository that collects the work of Arts et Métiers Institute of Technology researchers and makes it freely available over the web where possible.

This is an author-deposited version published in: <https://sam.ensam.eu>
Handle ID: <http://hdl.handle.net/10985/24712>

To cite this version :

Eric SEMAIL, Nadir IDIR, Souad HARMAND, Betty LEMAIRE-SEMAIL - Integrated drive and reliabilities: fault tolerant architectures and supply - 2022

Any correspondence concerning this service should be sent to the repository

Administrator : scienceouverte@ensam.eu



Integrated drive and reliabilities: fault tolerant architectures and supply

Eric Semail¹, Nadir Idir¹, Souad Harmand², Betty Lemaire-Semail¹

¹ Univ. Lille, Arts et Metiers Institute of Technology, Centrale Lille, Junia, ULR 2697, L2EP, F-59000 Lille, France

Email: betty.semail@univ-lille.fr

² Université Polytechnique des Hauts de France, CNRS, UMR 8201 LAMIH

Abstract – One major challenge of e-aerospace motor is high densities (kW/kg, Nm/kg) keeping a high functional reliability. With high switching frequency Voltage Source Inverter (VSI) using Wide-Band Gap (WBG) components, the DC-bus capacitor mass can be reduced. On contrary, because of very short commutation time (<50ns), the requirements for the connexion between VSI and machine terminals are higher. For a better proficiency, the integration of VSI inside the machine is then desirable. Besides, with WBG components, the temperature limit of the VSI is becoming higher than 150°C and consequently close to those of machines, favouring a common cooling and so, mass reduction. Finally, in integrated drive, the major drawback of fault-tolerant multiphase machines due to numerous external cables is alleviated. In order to benefit of this evolution, new topologies of integrated drive can be imagined. The paper examines different candidates of multiphase machines for integration and proposes an original topology taking into account simultaneously different constraints and opportunities.

I. INTRODUCTION

One major challenge of e-aerospace motor [1]-[2] is high torque and power densities (Nm/kg, kW/kg) while keeping a high level of functional reliability [3]. Voltage Source inverters (VSI) with WBG components (SiC and GaN) allow an increase of the Pulse Width Modulation (PWM) switching frequency. So a reduction of volume and mass of the DC-link capacitors can be obtained [4]. Nevertheless, new challenges appear [5], especially due to short switching times (related to high dv/dt) of WBG. Overvoltage (up to factor 2), depending of the cable length are imposed mainly at the first winding turns of the motor (“terminals”) [6][7], but also, overvoltage at the neutral end, in case of star coupling [8], can destroy the insulation or at least accelerate the aging of the motor especially when Corona effect (in end-windings) may occur, such as in aerospace (Paschen law) [9]. The structural reliability is then decreasing. If for low voltage applications (such as 48V DC voltage), a voltage margin of two for insulation is not too much a problem, it is less obvious for higher DC voltage such as those considered for aerospace applications (>400V), for mass constraint. As with integration of VSI, the reduction and proficiency of cable length is intrinsically obtained, integrated drive as already proposed for Electro-Hydrostatic Actuators [10], get an advantage upon classical drives.

Integrated Drives in transportation are existing since numerous years in research [11]-[16] or industrially in low power applications ([17], Figure 1), but with a relatively low power density because of the maximum working temperature of Si components, around 150°C, lower than the one available for windings insulation or permanent magnets. Recently, higher powers have been obtained, usually by merging the VSI case with the machine one ([18], Figure 2). The major benefit is then to propose a kind of ‘plug and play’ drive with only two external DC cables to connect to a battery without the EMI issues of AC

cables, but also to use only one cooling system. Nevertheless, with higher internal mechanical/vibration and thermal constraints in comparison separated VSI and machine classical drives, the sizing of the power Si components must be chosen to warrant the desired functional reliability, either by higher voltage/current safety margins, or by the choice of topologies tolerant to one component fault. Such topologies include either three-leg VSI but with transistors connected in parallel ([19], Figure 4), or VSI with more than three legs to get at least three independent currents with three phases [20]-[22].

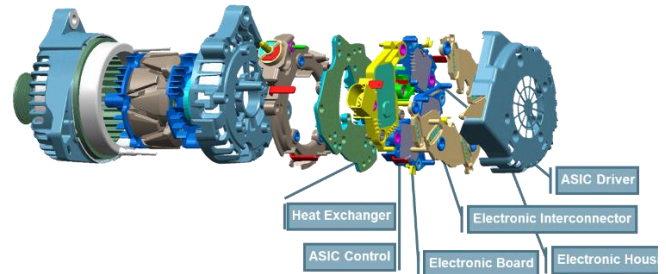

Figure 1: three-phase integrated drive for automotive from [17]

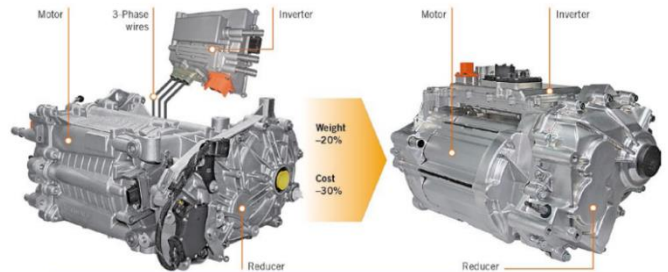

Figure 2: Integrated drive for automotive from [18]

With the emergence of WBG components, whose theoretical maximum temperature is much higher than 200°C [5] and more compatible with those of the other components of the drive, a new step can be considered for actuators in high temperature environment.

Nevertheless, according to Markov method [22]-[26], a higher complexity of the drive with a higher number of components decreases, the structural reliability. It is then convenient, if possible, to reduce the part of uncertainty in the manufacturing process (for the windings for example) and to consider preferably the functional reliability. Indeed, with a fault-tolerant drive, it is possible to maintain the wanted functionality, with a reduced demand [27]-[28], even if a few components are in fault. For a drive, the power components are statistically the less reliable ones and predictive maintenance is difficult to consider for them in comparison with bearings. So it is particularly important to consider the impact of a transistor

failing. For an integrated three-phase drive with recent WBG components [5], the required reliability can impose an overrating of the transistors, in contradiction with the research of mass reduction. The physical reason is that with only two independent currents to achieve the rotating field of the machine, there is no tolerance to a VSI-leg failing. If one phase is not supplied, the average torque is so low, and with so large torque ripples, that the machine can not run. The structural reliability can be reached only by imposing a high reliability for the VSI-leg. Practically, it is possible by considering several transistors in parallel for each leg ([19], Figure 3, Figure 4). But, because of initial unpairing between the transistors and, above all, growing differences with the life on the way, unequal repartition of tasks between transistors must be considered leading also to consequent safety margins necessity.



Figure 3: 3-leg VSI view with DC link capacitors from [19]

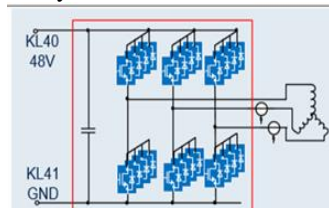

Figure 4: three-phase drive with transistor in parallel from [19]

Increasing the number of VSI legs over three and consequently the number of machine “phases” to supply is becoming an obviousness [4],[10],[29]-[31]. Nevertheless, for economical industrial constraints such as certification in aerospace or more generally the possibility to reuse previous development of three-phase drives, the simplest solution for industry is to just modify, if possible, existing three-phase machines. In this context, as usually one phase is obtained by series or parallel connexions of several coils, it can be imagine effectively to just modify the electrical connexions. One phase is then split into two or more phases electrically in parallel. Externally, it appears just several three-leg VSIs working in parallel. The obtained multi-phase machines are then in first approximation, multi three-phase machines. It is probably the reason why the most frequent multiphase machines are six-phase machines with two three-phase star coupled windings. Unfortunately, large parasitic currents can appear in such configuration if the control of the multi 3-leg VSIs is not done carefully and the machine not correctly chosen. The fundamental physical reason is the existence of magnetic couplings between the different three-phase windings. As a consequence the different k 3-leg VSI (k=1,2, etc) must be considered for the control as only one 3k-leg VSI with synchronisation and not independent ones. So the initial motivation to reuse previous 3-leg VSI is limited. For about twenty years, other kinds of multiphase machines have been developed, making profit of specific characteristics allowed by the “real” multiphase machines in terms of torque ripples, torque density (with 5 to 9 symmetrical machines) or performances in fault mode [31]-[37]. Of course, they are requiring new characterization and more intelligent and innovative controls but thanks to the increase of

computing power (FPGA and DSP), more complex algorithms of control can now be implemented in real time.

In this paper, after a review of the different configurations of multiphase drives obtained from three-phase machines, a novel topology of drive with WBG transistors is described. This topology [38] aimed to take into account simultaneously the different opportunities and constraints of technological evolution in order to improve reliabilities.

II. MULTI THREE-PHASE MACHINE DRIVES AND SYMMETRICAL n-PHASE DRIVES

It exists different kinds of multiphase machines with different properties. All of them allow a tolerance to VSI power components failure. The simplest ones, obtained from original three-phase machines, suffer in general, when supplied by VSI, from parasitic, also called circulating, high frequency currents (close to PWM carrier frequency). They also suffer from harmonic low frequency currents, even if average sinusoidal voltages are imposed. The amplitudes of the circulating currents depend on the value of mutual and leakage inductances. Specifically, for the high frequency circulating currents, the choice of the PWM strategy has also a great impact, while for the harmonic circulating currents, the topology of the control and the value of PI parameters are important.

This kind of problems have emerged more than twenty years ago [39] for high power systems such as electrical cruise ships with propulsion supplied by VSI (>5MW). A practical solution was then to add large inductances in series with the phases in order to limit the amplitude of high frequency currents. Effectively, even if these last ones can be easily filtered for the control and have a low impact on the torque quality, they lead to an oversizing of the power components and induce supplementary losses. With new applications of multiphase machines for automotive applications, with lower power, recent papers propose more intelligent solutions based on an increase of the computing power (FPGA, DSP) and machines with fractional slot winding. It must be remarked that with WBG components, the use of higher carrier frequency is more interesting than for three-phase machine characterized by only one electrical time constant. With multi three-phase machines, it is the smallest time constant (usually associated to leakage inductance) which is impacting the choice of the PWM frequency.

1>Multi three-phase machine without electrical shift

In Figure 5: from [40], segmentation or not of VSI with representation of possible lane for current circulation is represented. Without segmentation, but with the same number of transistors, no circulating currents are possible. It can be shown that for a given PWM strategy, it is, for machines with classical windings (integer value for spp^1), the value of the leakage inductances which limits the amplitude of HF circulating current. With new tooth concentrated windings machine (spp fractional number), it is no more the case. As a conclusion, if the machine is more simple to imagine in case of multi three-phase

¹ spp: number of slot per pole and per phase

configuration, the proficiency of the circulating currents is sensitive to the manufacturing of the windings.

Finally, in fault mode operation with open phase, the classical reconfiguration is to supply only the healthy three-phase windings with a loss of 50% of the power.

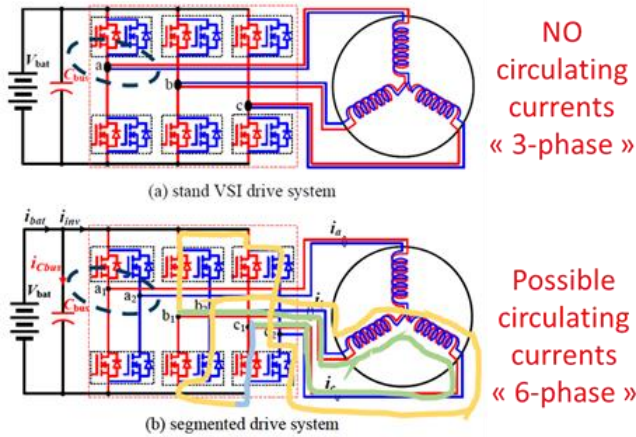

Figure 5: from [40], segmentation or not of VSI with representation of possible lane for current circulation

2>Multi three-phase machine with electrical shift angle

Based on a three-phase machine, it is often possible to achieve new coil couplings in order to obtain multi-star three-phase machine with electrical shift (see Figure 6, Figure 7). With this kind of machines, the torque ripple and the capacitor DC link current can be reduced [41]-[42]. Nevertheless, internal circulating currents are still possible [43]-[44], but, in comparison with previous multi three-phase machines without shift, these currents can be easier managed by new PWM strategies and adapted control. The most used machine is the double three-phase machine with a 30° electrical shift between the two three-phase windings and more recently triple three-phase machines with 20° electrical shift between the three three-phase windings [45]. It can be remarked that the transformation of a three-phase machine in a multi three-phase machine with electrical shift is not always possible.

Finally, it must be highlighted also that the attractive case of using two identical controls for each three-phase winding, not only induces circulating but also instabilities in the control [46].

In fault mode operation with open phase, the classical reconfiguration is to supply only the healthy three-phase windings with also a loss of 50% of the power.

3>Symmetrical n-phase machine

A symmetrical n-phase machine is characterized by an electrical angle between two successive phases of $2\pi/n$. The most studied symmetrical machines are with $n=3, 5, 7, 9, 11$. The properties of these machines are quite interesting in normal and also in fault mode in comparison with multi three-phase machines. In normal mode, the quality of torque and the torque density is increasing with the number of phases until about 13 phases when only one neutral point is considered.

Among these machines, the 9-phase symmetrical machine (40° between two successive phases [47]-[49]) may benefit of the industrial developments done for three-phase machines.

On contrary, in the case of triple three-phase windings configuration, the possibility to inject a third harmonic for increasing the torque is no more possible and fault tolerance reconfiguration is limited. When only one neutral is used with symmetrical n-phase machine, the loss of power is about $1/n$ when one phase is opened, instead of 33% with a triple star and 50% with a double star windings. Even in this case of triple-star coupling, [50] shows the interest of the nine-phase symmetrical machine for the reduction of the DC-bus capacitors.

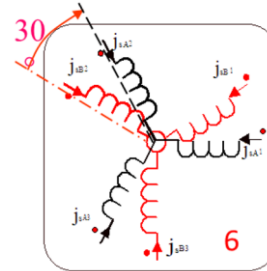

Figure 6: double three-phase machine windings



Figure 7: Triple three-phase machine windings from [45]

4> Modular/sectorized machines and Fault Tolerance

Numerous studies are done on multi three-phase modular machines with [51] (see Figure 8) with a spatial sectorization. When each sectorization modulus is done with a three-phase winding supplied by a three-leg VSI, a huge unbalance can be observed in fault mode with only one non-supplied sector. This kind of drawback has been studied. In [52] a decoupling control has been proposed.

Other solution are proposed for the design:

- Each three-phase modulus is associated to another one located at 180° mechanical angle [53]. When one modulus is not supplied, the other one at 180° is also opened. Mechanical unbalance due to radial forces is then reduced.
- Each neutral is supplied by one supplementary leg and a reconfiguration is done [55] in order to limit unbalance.

In conclusion, sectorized machines must be studied with cautious especially if a fault tolerance is required.

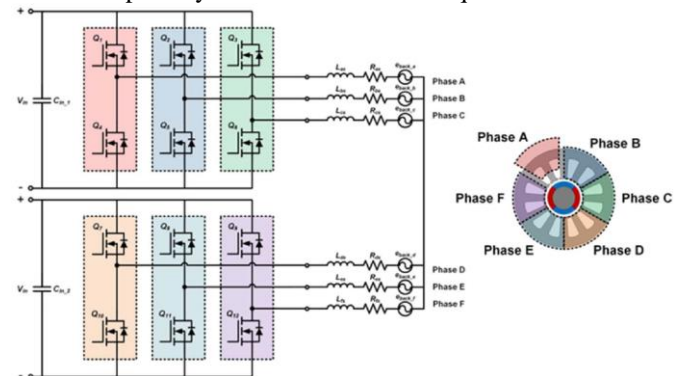

Figure 8: sectorized machine with VSI supply from [51]

III. PROPOSED INTEGRATED MULTIPHASE TOPOLOGY

In the first part, proposals are done in order to get a higher level of structural reliability for integrated drive. In this parts we describe how the proposed topology fullfills these requirements in terms of electromagnetic machine design, power converter and thermal design.

1> FOR Improving the Structural RELIABILITY:

a>Imposing structural symmetry and proposing heat pipes

In an aircraft, the mass impacts much more the global efficiency of the system than for terrestrial transportation. As a consequence, a high efficient (operating with low current density) but with a high mass can be less interesting than a lighter machine (operating with higher current density) but with a lower efficiency. In that case, the choice of the working current density can be much more higher than with a motor used in terrestrial transportation (5-10A/mm²).

In an electrical machine, the maximum temperature supported by the insulation and the magnets are the major limiting factors. During extreme transient operation, the current density can be highly increased (over 10A/mm²) and the copper windings are the first elements which need to evacuate their heat in order to limit the increase of temperature. The maximum current density is estimated accounting for the location in the windings, where the temperature is the highest for the insulation [9], [56]. The topology of the machine is of interest to avoid hot spot genesis. It can be assumed that it is best to avoid asymmetries in heat flow either radially or axially. Thus, the topology will impose a symmetry with respect to an orthogonal plane passing through the middle of the machine at first and finally by using one VSI at each side of the machine. In order to reduce the gradient of temperature along axial direction for high speed machine with a low ratio diameter/length, axial cooling, in addition with natural radial cooling, is of interest. As an example, in the proposed topology, heat pipes are inserted symmetrically inside each slot of the machine and also inside the rotor. Their non-linear thermal resistance can be a good way to limit thermal runaway. Other proposals with other disposal of heat pipes can be found in [57]-[59].

b>Imposing concentrated tooth slot machine (fractional winding)

Considering the thermal constraints and also the dielectric ones imposed by the use of VSI with WBG components, it can be considered as preferable that the coils of the different phases do not have physical contact between them especially in end-windings axial parts. Hairpin windings for machine with classical integer spp can be used [6]. The end-windings are then better overcome but remain complex to manufacture and consume space. For more recent machines with tooth concentrated windings (spp is a fractional number), it is also possible to ensure a proficiency of the wire position inside the winding, which are besides convenient for modular machines. But even if these machines allow very short end-

windings, undesired properties in terms of torque ripple, eddy currents losses and vibrations due to unbalanced magnetic pull require careful choices for spp. For three-phase machines 12kslots/8kpoles and 12k slots/10kpoles (k=1,2,etc) are commonly used in automotive applications. For multiphase machines, different studies have been conducted to find compromise [60]-[63]. Finally, in order to be able to overcome the reproductibility of coils there are made outside the machine. So, the slot have to be opened in order to be able to insert them easily. This process for insertion of coils induces a space at the basis of the slot. This space has been replaced by a small tooth in which is inserted statoric insulated heat pipe (see Figure 18 and Figure 19). Thus the filling factor is increased by insertion of cooling very close to the origin of heat.

c>Imposing open-winding topology

in spite of imposing more VSI legs, open-end windings topology is considered as preferable because it :

- allows to impose the full DC voltage to each phase and consequently, for a given power, to divide by two about the phase current ;
- adds degrees of freedom for the PWM control, interesting for overvoltages mitigation [64] ;
- reduces, with WBG components, the voltage constraints due to fluctuation of neutral-core voltage potential [8] ;
- is also favourable to drives requiring two independent DC voltage sources for fault tolerance concerning the DC supply.

d>Increasing thermal symmetry by heat pipes

In order to give to the machine an ability for transient operation with non-linear resistance but without imposing liquid cooling with external pump and variable flow, heat pipes have been considered both for the rotor, to protect permanent magnets, and for the stator. The location of statoric heat pipes is particular and benefits from the constraints on tooth concentrated windings and open-slot. It has been possible to insert heat pipe in a tooth inside each slot with dielectric insulation. Thanks to very short end-winding, condenser of heat pipe can have been inserted.

In table 1, a sum-up is presented with the solutions brought to the weak points of a machine for use with WBG.

TABLE 1 sum-up of considered challenging points for improving structural reliability of integrated drive with WBG

Classical drive weak points for use of WBG	Associated risk	Proposed Solution (adopted in proposed topology)
Cable between VSI and machine	Machine overvoltage inducing short-circuit in first turns	1>Overating insulation 2>Shorten the cable length by integration 3>Non random winding for the coil: hairpin winding or making coils outside with insertion around each tooth (fractional winding)

		4> Prediction calculation (software) No contact
Short circuit between coils of different phases in end-windings	Breakdown Insulation in end-windings (particularly in low pressure air/Corona-Paschen)	1>by Hairpin (classical machine wit integer) spp 2>by tooth concentrated winding (fractionnal winding machine with spp fraction) Spp! Number of slots per pole and per phases
Fluctuation of machine neutral point Voltage	Breakdown or accelerated aging of coil insulation	„Open-winding” topology with full-bridge supply for each phase with interest of doubling the phase voltage with same DC-bus value
Classical challenges for Integrated Drive	Associated risk	Solution (adopted in proposed topology)
Constraint on DC-link capacitors	No supply	1>Derating capacitors 2>Split the constraints between two VSIs 3>Reducing capacitor current ripple with increasing the number of phases 4>Multilevel Flying Capacitors VSI
Transmission of machine vibrations to Printing circuit board (PCB)	Aging or destruction of PCB and DC source	1>Multiphase machine with intrinsic low torque ripple and radial forces balance 2> Strategies of control in fault mode operation
Non symmetrical heat flux due to barrier (for example connexion between coils)	Creation of hot spots inducing limitations	1>symmetrical construction guaranteeing symmetry of heat flow: the terminal connection of coils are symmetrically distributed on both axial side of the machine 2>symmetrical heat pipes with non-linear thermal resistance are proposed for transient operation

2> Example of multi-phase machine topology

In this paragraph, we give a few elements concerning two prototypes which have been achieved to implement the proposed topology. In both cases the machine is fractionnal with 20 slots, 20 coils, 14 poles ($spp=2/7$) in order to warrant good compromise mainly considering torque ripple, winding factor and efficiency [62]. Various configurations can be defined for the number of phases mainly depending on the constraints on the number of legs for the VSI and the number of DC-bus sources.

On Figure 9, it is a 5-phase open-winding configuration with only one common DC-bus source and by two 5-leg VSIs.

On Figure 10, it is a 10-phase (or double 5-phase) in open-end-winding supplied by two independent DC-bus sources.

With more than three phases, fonctionnal reliability in different fault modes have been published for the five-phase machine;

- opened phases [65]
- transistor always opened or in short-circuit [66]
- associated fault detections [67]-[69]
- Reconfiguration control with different strategies [65],[70]

When one phase is opened, it is not necessary to open two other phases to be able to develop torque with low ripples as it is the case with multi three-phase machines.

On Figure 11 the configuration of Figure 9 has been implemented in an existing five-phase machine (prototype 1) by the addition of two five-leg VSI (Figure 16) on each axial extremities. The connexions (in blue) between machine and VSIs are still external.

On Figure 12 and Figure 13, it can be seen on the prototype1 that, even with concentrated tooth winding, the connexion of 4 coils in series in order to obtain each phase induces a non symmetrical disposal which is at the origin of disymmetry on the temperature repartition in comparison with the virtual prototype (Figure 14).

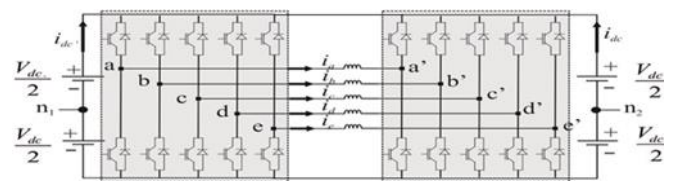

Figure 9: 5-phase open winding PMSM and its inverter with only one DC voltage source, each phase is obtained by connection of four coils

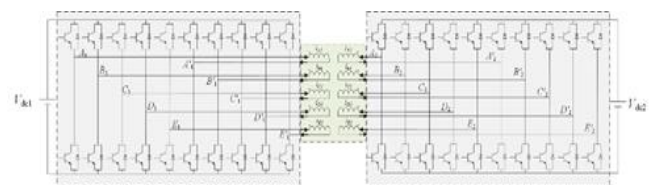

Figure 10: Open windings with ten-phase machines and two independent DC-bus voltage

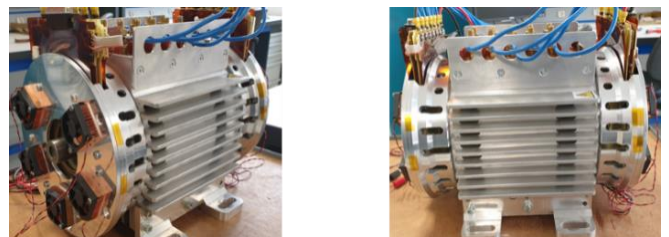

Figure 11: views of one 5-phase PMSM prototype 1 with the two VSI parts on each axis side external connection between 5-leg VSI and 5-phase machine

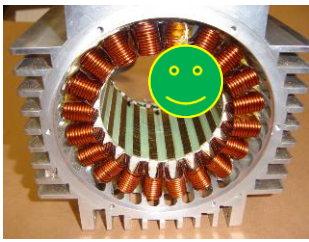

Figure 12: Front end of tooth concentrated winding without contact between coils of prototype 1

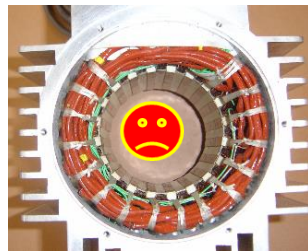

Figure 13: undesired back-end of windings with connexions between coils of prototype 1

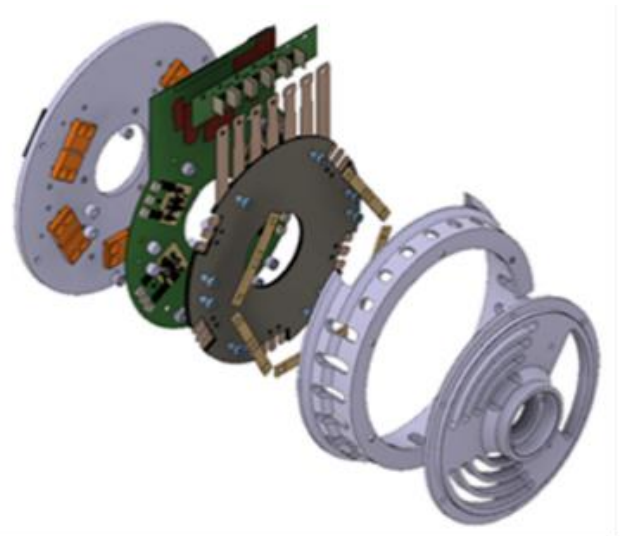

Figure 16 exploded view of one VSI with five-leg for prototype 1

In Figure 15 an exploded view of the machine with rotoric and statoric heat pipe symmetrically inserted in the iron sheets can be seen. In Figure 17, connection disks have been added and a zoom of the end winding with heat pipe statoric condenser and copper coil can be seen. More details on the location and the way to insert statoric insulated heat pipe in iron sheet tooth defined in each slot can be found (Figure 18 and Figure 19).

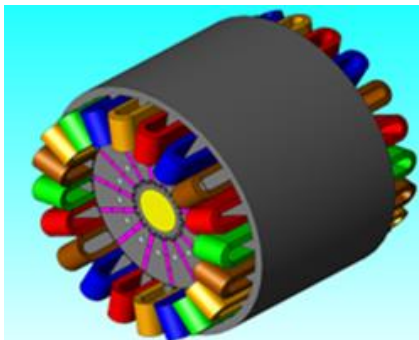

Figure 14: virtual view of prototype 1

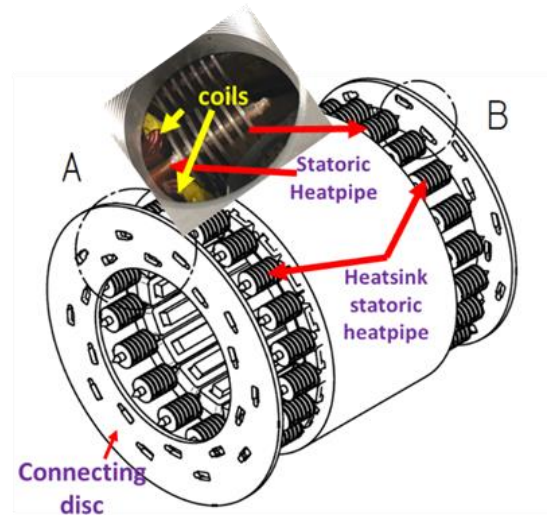

Figure 17: example of symmetrical connections of coils with two axial connecting discs and statoric heat pipes ended by condensers

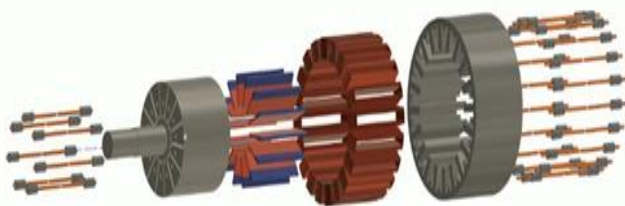

Figure 15: Exploded view of the symmetrical machine with 20 open-slot stator, 20 tooth concentrated coils, 14 internal magnets and statoric and rotoric heat pipes, prototype 2

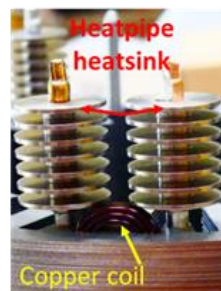

Figure 18: Condenser of the heat pipe over short end-winding coils

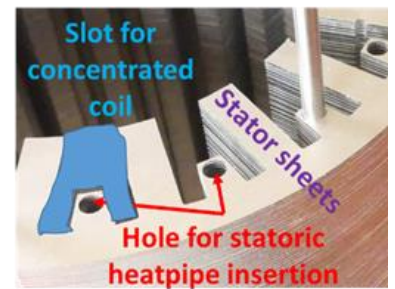

Figure 19: open slots of stator sheet with hole for heat pipe insertion

3> Inverter design of the integrated prototype

For the making of the integrated VSI (5-Leg inverter) in the machine, it is necessary to select the power components corresponding to the technical specifications of the prototype. Thus, starting from the electrical, thermal constraints and the dimensions of the converter PCB (surfaces available on both sides of the disk), a comparative study of the different power component technologies (Si, SiC and GaN) was carried out. The obtained results of this study show that, for this application and the constraint on the available surface of the PCB (Figure 20), the GaN transistors constitute the best solution for the realization of the integrated VSI. The advantages of the chosen GaN transistor 100V@90A at 25°C (GS61008T- GaN Systems) are: PCB footprint is very low (7.0x4.0mm², with 0.54mm thickness), a thermal pad on the high side and the component is bidirectional in current (does not require a reverse parallel diode, Figure 21).

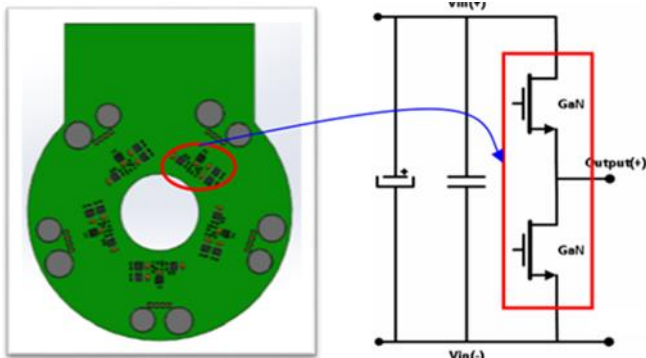

Figure 21: PCB geometry of on side of the inverter

Thermal simulations of GaN transistors with their cooling systems are carried out and the obtained results are shown in Figure 22 for different leg-conduction situations of the inverter.

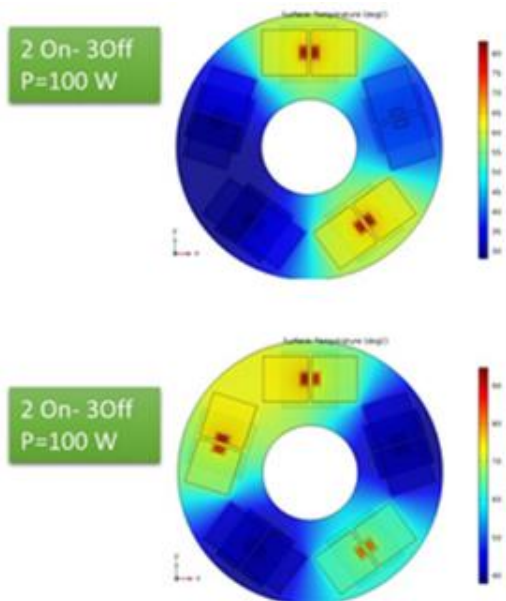

Figure 22: thermal simulations of different conducting situations for the 5 legs VSI

Electrical and thermal simulation results are validated on a single leg. The second step consisted in making the converter, a photo of the PCB from the side of the low voltage level circuits (drivers, power supply, current sensor and protections) is shown in Figure 23. The converter with its cooling system is made then insert into the machine as shown in Figure 11.

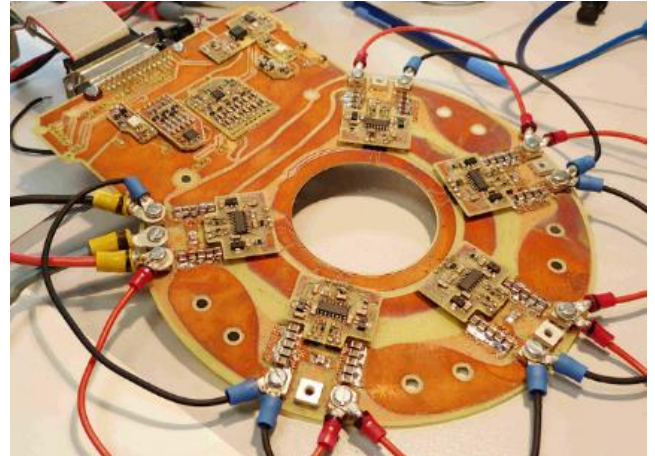

Figure 23: 5-leg GaN inverter realization

4>Cooling system: heat pipes

For machine working at high current densities, liquid cooling is usually used with a water jacket above the magnetic frame of the stator [71]-[72] and more rarely in the stator sheet [73]. It is then possible to increase the cooling during transients by changing the rate of flow but with the drawback of necessary external pump. For the PM rotor, sometimes cooling is assumed by flow circulating inside the rotation axis but it is not easy [74].

Heat pipes have been chosen in stator and also in rotor because of their thermal non-linear characteristic. Their properties are in adequation with transient operation requiring more torque during a few minutes. Moreover, for the purpose of design of motor drive, passive cooling solutions are favored above all for reasons of compactness. Hence, implanting heat pipes in our electrical machines is relevant.

In our prototype, static heat pipes are used to cool down the stator / coils where revolving heat pipes are set to protect the magnet in the rotor.

The heat pipe is a heat superconductor operating in a closed cycle according to the evaporation-condensation principle, with liquid return either by gravity or by capillarity. Its interest comes from the very high value of the latent heat of phase change compared to the specific heat. It consists of a hermetically sealed enclosure containing a refrigerant. The choice of heat transfer fluid depends on the expected working temperature.

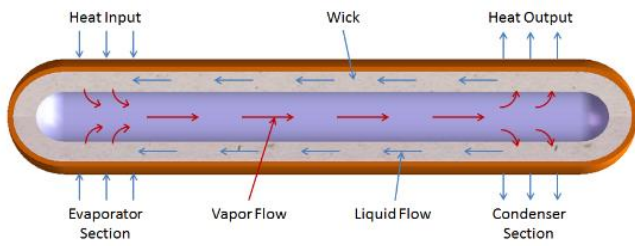

Figure 24 Principle of heat pipe working

Several static heat pipes have been implemented in the stator sheet. Each static heat pipe is made of copper, with a diameter of 4 mm and a length of 23.5 mm. In the condenser part, aluminum fins have been brazed with an exchange surface of 34 cm².

For a maximum power of 27.1 Watts (corresponding to losses at 9000 rpm distributed over 2x20 heat pipes), these heat pipes will be able to operate in all orientations with a conductance estimated to 1.9 W/K.

Statoric heat pipe was inserted in holes in iron sheet inside each slots with thin insulation resine.

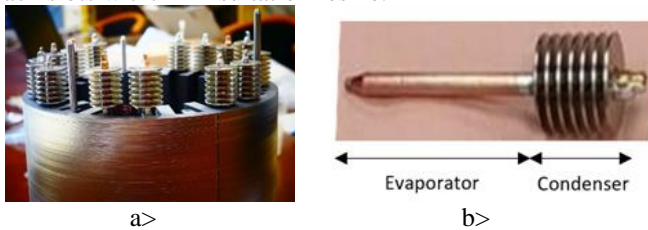

Figure 25 a) stator of the 5-phase PMSM equipped with heat pipes
b) separated static heat pipe

The revolving heat pipes used for the cooling of the rotor are hollow copper tubes, with an outer diameter of 4 mm and a wall thickness of 0.4 mm. The length of the evaporator (part inserted in the rotor) is 40mm and the condenser part (equipped with annular fins) is 15.5mm. This heat pipe uses water as a working fluid. A specific test bench has been developed in order to determine the thermal conductance of these heat pipes as a function of the rotation speed and the applied heat power at evaporator. This last one is estimated to be 0.9 W/K for 16000 rpm.

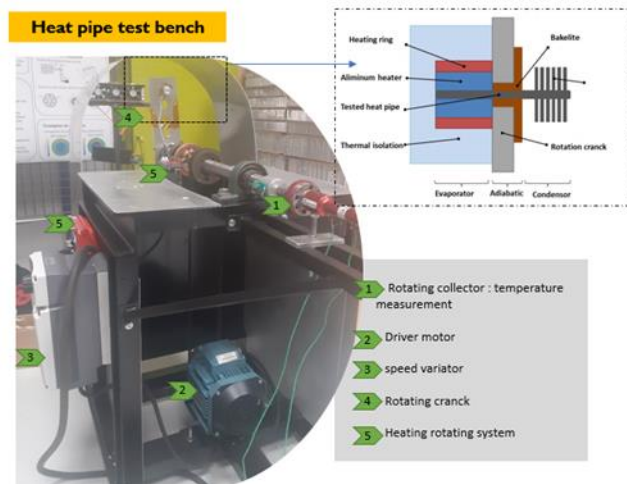

Figure 26: Experimental setup for revolving heat pipe

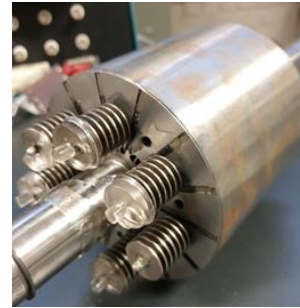

Figure 27: Rotor of the 5-phase PMSM equipped with revolving heat pipes

IV. CONCLUSION

After analysis of opportunities for integrated drives associated to emergence of Wide Band Gap Components, different topologies of machine ensuring the functional reliability are discussed with their advantages and drawbacks. A topology taking into account the different constraints and evolution is proposed with associated prototypes. In integrated drive technological, challenges are closely mixed with scientific technological including the requirement of high quality virtual prototypes.

V. ACKNOWLEDGMENT

This work has been achieved within the framework of CE2I project (Convertisseur d' Energie Intégré Intelligent). CE2I is co-financed by European Union with the financial support of European Regional Development Fund (ERDF), French state and the French Region of Hauts-de-France

VI. REFERENCES

- [1] F. Anton, « Aircraft hybrid-electric propulsion disrupting the way you will fly», 14th ed.; Tag der Deutschen Luft-und Raumfahrtregionen, Potsdam, Germany, Siemens AG: Berlin, Germany, 2019. <https://www.bbbaa.de/>
- [2] Filipenko, M.; Biser, S.; Boll, M.; Corduan, M.; Noe, M.; Rostek, P. Comparative Analysis and Optimization of Technical and Weight Parameters of Turbo-Electric Propulsion Systems. *Aerospace* 2020, 7, 107. <https://doi.org/10.3390/aerospace7080107>
- [3] A. El-Refaie and M. Osama, "High specific power electrical machines: A system perspective," in *CES Transactions on Electrical Machines and Systems*, vol. 3, no. 1, pp. 88-93, March 2019
- [4] T. M. Jahns and B. Sarlioglu, "The Incredible Shrinking Motor Drive: Accelerating the Transition to Integrated Motor Drives," in *IEEE Power Electronics Magazine*, vol. 7, no. 3, pp. 18-27, Sept. 2020
- [5] A. K. Morya et al., "Wide Bandgap Devices in AC Electric Drives: Opportunities and Challenges," in *IEEE Transactions on Transportation Electrification*, vol. 5, no. 1, pp. 3-20, March 2019.
- [6] X. Ju et al., "Voltage Stress Calculation and Measurement for Hairpin Winding of EV Traction Machines Driven by SiC MOSFET," in *IEEE Transactions on Industrial Electronics*, vol. 69, no. 9, pp. 8803-8814, Sept. 2022,.
- [7] Y. Xu et al., "Impact of High Switching Speed and High Switching Frequency of Wide-Bandgap Motor Drives on Electric Machines," in *IEEE Access*, vol. 9, pp. 82866-82880, 2021.
- [8] S. Sundeep, J. Wang, A. Griffo and F. Alvarez-Gonzalez, "Antiresonance Phenomenon and Peak Voltage Stress Within PWM Inverter Fed Stator Winding," in *IEEE Transactions on Industrial Electronics*, vol. 68, no. 12, pp. 11826-11836, Dec. 2021.

- [9] Greg C. Stone, Ian Culbert, Edward A. Boulter, Hussein Dhirani, *Electrical Insulation for Rotating Machines: Design, Evaluation, Aging, Testing, and Repair*, 2nd Edition July 2014 Wiley-IEEE Press 672 Pages,
- [10] W. Lee, S. Li, D. Han, B. Sarlioglu, T. A. Minav and M. Pietola, "A Review of Integrated Motor Drive and Wide-Bandgap Power Electronics for High-Performance Electro-Hydrostatic Actuators," in *IEEE Transactions on Transportation Electrification*, vol. 4, no. 3, pp. 684-693, Sept. 2018
- [11] N. R. Brown et al., "Power converter design for an integrated modular motor drive," in *Proc. IEEE Industry Applications Annu. Meeting*, New Orleans, LA, 2007, pp. 1322-1328.
- [12] A. Shea et al., "Hardware integration for an integrated modular C. Gerada and K. J. Bradley, "Integrated PM Machine Design for an Aircraft EMA," in *IEEE Transactions on Industrial Electronics*, vol. 55, no. 9, pp. 3300-3306, Sept. 2008.
- [13] Wolmarans, J.J.; Gerber, M.B.; Polinder, H.; De Haan, S. W H; Ferreira, J.A.; Clarenbach, D., "A 50kW integrated fault tolerant permanent magnet machine and motor drive," *Power Electronics Specialists Conference*, 2008. PESC 2008. IEEE, vol., no., pp.345,351, 15-19 June 2008
- [14] Hennen, M.D.; Niessen, M.; Heyers, C.; Brauer, H.J.; De Doncker, R.W., "Development and Control of an Integrated and Distributed Inverter for a Fault Tolerant Five-Phase Switched Reluctance Traction Drive," *Power Electronics*, *IEEE Transactions on*, vol.27, no.2, pp.547,554, Feb. 2012
- [15] P. Brockerhoff, W. Schon, P. Blaha, P. Vaclavek, et Y. Burkhardt, « Disc inverter in highly integrated 9-phase drivetrain for E-mobility », *European Conference on Power Electronics and Applications (EPE'15 ECCE-Europe)*, Geneva, Switzerland, 2015, p. 1-9.
- [16] J. Wettlaufer, H. Borcherding, F. Klute and T. Jonsky, "A compact servo drive: Five phase, air cooled, with highly integrated inverter for industrial use," 2015 17th *European Conference on Power Electronics and Applications (EPE'15 ECCE-Europe)*, Geneva, 2015, pp. 1-10.
- [17] D. Richard and Y. Dubel, "Valco STARS Technology: A Competitive Solution for Hybridization," 2007 *Power Conversion Conference - Nagoya*, 2007, pp. 1601-1605,
- [18] G. Mühlberg, W. Hackmann, K. Buzziol, "Highly Integrated Electric Powertrain". *ATZ Elektron Worldw* 12, 42-45 (2017). <https://doi.org/10.1007/s38314-017-0048-8>
- [19] R. Rong, "AN-Power stage of 48V BSG inverter", Application note, 2018 https://www.infineon.com/dgdl/Infineon-20180802_AN-Power_stage_of_48V_BSG_inverter_V2.2-AN-v01_00-EN.pdf?fileId=5546d46265487f7b0165a3863b8e5bcf last access in 09/2022n
- [20] B.A. Welchko, T.A.; Lipo, T.M. Jahns, S.E. Schulz, "Fault tolerant three-phase AC motor drive topologies: a comparison of features, cost, and limit", *IEEE Transactions on Power Electronics*, Vol. 19, Issue 4, July 2004, pp-1108 - 1116.
- [21] Wenping Cao, B. C. Mecrow, G. J. Atkinson, J. W. Bennett, and D. J. Atkinson, "Overview of Electric Motor Technologies Used for More Electric Aircraft (MEA)," *IEEE Transactions on Industrial Electronics*, vol. 59, no. 9, pp. 3523-3531, Sep. 2012.
- [22] J. W. Bennett, G. J. Atkinson, B. C. Mecrow, and D. J. Atkinson, "Fault-Tolerant Design Considerations and Control Strategies for Aerospace Drives," *IEEE Transactions on Industrial Electronics*, vol. 59, no. 5, pp. 2049-2058, May 2012.
- [23] J. W. Bennett, "Fault Tolerant Electromechanical Actuators for Aircraft," PhD Thesis, Newcastle University, Newcastle, UK, 2010.
- [24] W. Li, *Risk Assessment of Power Systems*. United States of America: IEEE Press, Wiley-Interscience, 2005.
- [25] F. Meinguet, "Fault-tolerant permanent-magnet synchronous machine drives Fault detection and isolation, control reconfiguration and design considerations," PhD Thesis, Université Libre de Bruxelles, Brussels, Belgium, 2012.
- [26] Jörg Johannes Kammermann, "Potential Analysis of Electrical Drive Trains According to Application Requirements" PhDthesis, Technical University of Munich, 2019
- [27] J. Kammermann, I. Bolvashenkov and H. Herzog, "Improvement of Reliability and Fault Tolerance of Traction Drives by Means of Multiphase Actuators," *Drive Systems 2017; 7th VDE/VDI Symposium*, 2017, pp. 1-6.
- [28] I. Frenkel, L. Khvatskin, E. Ikar, I. Bolvashenkov, H-G Herzog, A. Lisnianski, « Reliability and Fault Tolerance Modeling of Multiphase Traction Electric Motors », chap 12 of « Modeling and Simulation Based Analysis in Reliability Engineering », CRC press, 2018
- [29] E. Levi, "Advances in converter control and innovative exploitation of additional degrees of freedom for multiphase machines," *IEEE Trans. Ind. Electron.*, vol. 63, no. 1, pp. 433-448, Jan. 2016.
- [30] E. Sayed et al., "Review of Electric Machines in More-/Hybrid-/Turbo-Electric Aircraft," in *IEEE Transactions on Transportation Electrification*, vol. 7, no. 4, pp. 2976-3005, Dec. 2021.
- [31] M. J. Duran, E. Levi, F. Barrero, « Multiphase Electric Drives: Introduction » in *Wiley Encyclopedia of Electrical and Electronics Engineering*, 2017 doi.org/10.1002/047134608X.W8364
- [32] E. Levi, "Multiphase Electric machines for Variable Speed Applications", *IEEE Trans. on Industrial Electronics*, vol. 55, n°5, May 2008, pp. 1893-1909
- [33] F. Barrero and M. J. Duran, "Recent Advances in the Design, Modeling, and Control of Multiphase Machines—Part I," in *IEEE Transactions on Industrial Electronics*, vol. 63, no. 1, pp. 449-458, Jan. 2016, doi: 10.1109/TIE.2015.2447733.
- [34] M. J. Duran and F. Barrero, "Recent Advances in the Design, Modeling, and Control of Multiphase Machines—Part II," in *IEEE Transactions on Industrial Electronics*, vol. 63, no. 1, pp. 459-468, Jan. 2016, doi: 10.1109/TIE.2015.2448211.
- [35] E. Levi, Chap3 «Multiphase AC Machines » in *Power Electronics and Motor Drives*, The Industrial Electronics Handbook Edited by: Bogdan M. Wilamowski, J. David Irwin eBook ISBN: 978143980286, 2011 second edition
- [36] X. Kestelyn, E. Semail, "Vectorial Modeling and Control of Multiphase Machines with Non-salient Poles Supplied by an Inverter", Chap5 in book "Control of Non-conventional Synchronous Motors", ISTE Ltd and John Wiley & Sons Inc, 2012, 44 pages.
- [37] X. Kestelyn, E. Semail, "Multiphase Voltage Source Inverters" chap 8 in book "Power Electronic Converters: PWM Strategies and Current Control Techniques", Eric Monmasson, ISBN. 978-1-84821-195-7. ISTE Ltd and John Wiley & Sons Inc, mars 2011, 27 pages.
- [38] E. Semail, S. Harmand, N. Idir, B. Lemaire-Semail, «Integrated Polyphase Electric Machine», Patent WO2022136804_A1, 30/06/2022.
- [39] N. Moubayed, F. Meibody-Tabar, B. Davat and I. Rasoanarivo, « Conditions of Safely Supplying of DSIM by two PWM-VSI » *EPE, Lausanne*, 1999
- [40] S. Chowdhury, E. Gurpinar, G. -J. Su, T. Raminosa, T. A. Burress and B. Ozpineci, "Enabling Technologies for Compact Integrated Electric Drives for Automotive Traction Applications," *IEEE Transportation Electrification Conference and Expo (ITEC)*, 2019, pp 1-8
- [41] N. Rouhana, E. Semail and J. -F. Duguey, "Impact of PWM Strategies on RMS Current of the DC-Link Voltage Capacitor of a Dual-Three Phase Drive," 2014 *IEEE Vehicle Power and Propulsion Conference (VPPC)*, 2014, pp. 1-7.
- [42] Marija Vujacic, Obrad Dordevic, Gabriele Grandi, "Evaluation of DC-Link Voltage Switching Ripple in Multiphase PWM Voltage Source Inverters", *IEEE Transactions on Power Electronics*, vol.35, no.4, pp.3478-3490, 2020.
- [43] D. Hadiouche, H. Razik and A. Rezzoug, "On the modeling and design of dual-stator windings to minimize circulating harmonic currents for VSI fed AC machines," in *IEEE Transactions on Industry Applications*, vol. 40, no. 2, pp. 506-515, March-April 2004
- [44] D. Ye, J. Li and R. Qu, "Circulating Harmonic Currents Prediction for VSI Fed Dual Three-Phase IPMSM," 2019 *IEEE International Electric Machines & Drives Conference (IEMDC)*, 2019, pp. 1778-1783,
- [45] Y. Burkhardt, A. Spagnolo, P. Lucas, M. Zavesky, P. Brockerhoff, « Design and analysis of a highly integrated 9-phase drivetrain for EV applications », *ICEM'2014*, Berlin, Germany, 2014, p. 450-456.
- [46] Y. Hu, Z. Q. Zhu and M. Odavic, "Comparison of Two-Individual Current Control and Vector Space Decomposition Control for Dual Three-Phase PMSM," in *IEEE Transactions on Industry Applications*, vol. 53, no. 5, pp. 4483-4492, Sept.-Oct. 2017
- [47] L. Verkroost, J. Van Damme, D. V. Bozalakov, F. De Belie, P. Sergeant and H. Vansompel, "Simultaneous DC-Link and Stator Current Ripple Reduction With Interleaved Carriers in Multiphase Controlled Integrated

- Modular Motor Drives," in *IEEE Transactions on Industrial Electronics*, vol. 68, no. 7, pp. 5616-5625, July 2021.
- [48] M. Farshadnia, M. A. M. Cheema, A. Pouramin, R. Dutta, and J. E. Fletcher, "Design of optimal winding configurations for symmetrical multiphase concentrated-wound surface-mount PMSMs to achieve maximum torque density under current harmonic injection," *IEEE Trans. Ind. Electron.*, vol. 65, no. 2, pp. 1751-1761, Feb. 2018.
- [49] M. Slunjski, O. Stiscia, M. Jones and E. Levi, "General Torque Enhancement Approach for a Nine-Phase Surface PMSM With Built-In Fault Tolerance," in *IEEE Transactions on Industrial Electronics*, vol. 68, no. 8, pp. 6412-6423, Aug. 2021,
- [50] S. Piepenbreier et al., "Analysis of a Multiphase Multi-Star PMSM Drive System with SiC-Based Inverter for an automotive application," *PCIM Europe 2018; International Exhibition and Conference for Power Electronics, Intelligent Motion, Renewable Energy and Energy Management*, 2018, pp. 1-10.
- [51] W. Lee, S. Li, D. Han, B. Sarlioglu, T. A. Minav, M. Pietola, « Achieving high-performance electrified actuation system with integrated motor drive and WBG power electronics », *EPE'17 ECCE Europe*, Warsaw, Poland, 2017, p. 1-10
- [52] M. Slunjski, O. Stiscia, M. Jones and E. Levi, "General Torque Enhancement Approach for a Nine-Phase Surface PMSM With Built-In Fault Tolerance," in *IEEE Transactions on Industrial Electronics*, vol. 68, no. 8, pp. 6412-6423, Aug. 2021
- [53] Y. Sui et al., "Multiphase Modular Fault-Tolerant Permanent-Magnet Machine With Hybrid Single/Double-Layer Fractional-Slot Concentrated Winding," in *IEEE Transactions on Magnetics*, vol. 55, no. 9, pp. 1-6, Sept. 2019, Art no. 7500506.
- [54] S. Rubino, O. Dordevic, R. Bojoi and E. Levi, "Modular Vector Control of Multi-Three-Phase Permanent Magnet Synchronous Motors," in *IEEE Transactions on Industrial Electronics*, vol. 68, no. 10, pp. 9136-9147, Oct. 2021.
- [55] F. Chai, L. Gao, Y. Yu and Y. Liu, "Fault-Tolerant Control of Modular Permanent Magnet Synchronous Motor Under Open-Circuit Faults," in *IEEE Access*, vol. 7, pp. 154008-154017, 2019
- [56] P. Giangrande, V. Madonna, S. Nuzzo and M. Galea, "Moving Toward a Reliability-Oriented Design Approach of Low-Voltage Electrical Machines by Including Insulation Thermal Aging Considerations," in *IEEE Transactions on Transportation Electrification*, vol. 6, no. 1, pp. 16-27, March 2020.
- [57] F. Wu, A. M. EL-Refaie and A. Al-Qarni, "Additively Manufactured Hollow Conductors Integrated With Heat Pipes: Design Tradeoffs and Hardware Demonstration," in *IEEE Transactions on Industry Applications*, vol. 57, no. 4, pp. 3632-3642, July-Aug. 2021
- [58] R. Wrobel and R. J. McGlen, "Opportunities and Challenges of Employing Heat-Pipes in Thermal Management of Electrical Machines," *2020 International Conference on Electrical Machines (ICEM)*, 2020, pp. 961-967.
- [59] Yalong Sun, Shiwei Zhang, Gong Chen, Yong Tang, Fuye Liang, "Experimental and numerical investigation on a novel heat pipe based cooling strategy for permanent magnet synchronous motors, *Applied Thermal Engineering*," Volume 170, 2020, 114970, pp1-10
- [60] N. Bianchi, S. Bolognani, M.D. Pre, G. Grezzani, "Design considerations for fractional-slot winding configurations of synchronous machines," *IEEE Trans. on Industry Applications*, vol.42, no.4, pp. 997-1006, July-Aug. 2006.
- [61] R. Wrobel, P.H. Mellor, "Design Considerations of a Direct Drive Brushless Machine with Concentrated Windings," *IEEE Trans. on Energy Conversion*, vol.23, no.1, pp.1-8, March 2008.
- [62] B. Aslan, E. Semail, J. Korecki and J. Legranger, "Slot/pole combinations choice for concentrated multiphase machines dedicated to mild-hybrid applications," *IECON 2011 - 37th Annual Conference of the IEEE Industrial Electronics Society*, 2011, pp. 3698-3703,
- [63] E. Fornasiero, L. Alberti, N. Bianchi and S. Bolognani, "Considerations on Selecting Fractional-Slot Nonoverlapped Coil Windings," in *IEEE Transactions on Industry Applications*, vol. 49, no. 3, pp. 1316-1324, May-June 2013
- [64] S. De Caro et al., "Motor Overvoltage Mitigation on SiC MOSFET Drives Exploiting an Open-End Winding Configuration," in *IEEE Transactions on Power Electronics*, vol. 34, no. 11, pp. 11128-11138, Nov. 2019.
- [65] X. Kestelyn, E. Semail, "A Vectorial Approach for Generation of Optimal Current References for Multiphase Permanent Magnet Synchronous Machines in Real-time", *IEEE Transactions on Industrial Electronics*, Vol 58, N°11, pp5057-5065, Nov 2011
- [66] N.K. Nguyen, F. Meinguet, E. Semail, X. Kestelyn, "Fault-Tolerant Operation of an Open-End Winding Five-Phase PMSM Drive with Short-Circuit Inverter Fault", *IEEE Transactions on Industrial Electronics*, Vol 63, N°1, pp 595- 605, Jan. 2016,
- [67] M. Trabelsi, N.K. Nguyen, E. Semail, "Real-time Switches Fault Diagnosis based on Typical Operating Characteristics of Five-Phase Permanent Magnet Synchronous Machines", *IEEE Tran. on Indus. Elect.*, Vol 63, N°8, Aug. 2016 pp. 4683-4694, August 2016,
- [68] M. Trabelsi, E. Semail, N. K. Nguyen, "Experimental Investigation of Inverter Open-Circuit Fault Diagnosis for Bi-Harmonic Five-Phase Permanent Magnet Drive," *Journal of Emerging and Selected Topics in Power Electronics (JESTPE)* , vol. 6, no.1, pp.339-351, March 2018,
- [69] M. Trabelsi, E. Semail, « Virtual current vector-based method for inverter open-switch and open-phase fault diagnosis in multiphase permanent magnet synchronous motor drives », *IET Electric Power Applications*, April 2021
- [70] D. T. Vu, N. K. Nguyen, E. Semail and T. J. dos Santos Moraes, "Control strategies for non-sinusoidal multiphase PMSM drives in faulty modes under constraints on copper losses and peak phase voltage," *IET Electric Power Applications*, vol. 13, no. 11, pp. 1743-1752, 2019,
- [71] Y. Gai et al., "Cooling of Automotive Traction Motors: Schemes, Examples, and Computation Methods," in *IEEE Transactions on Industrial Electronics*, vol. 66, no. 3, pp. 1681-1692, March 2019
- [72] P. -O. Gronwald and T. A. Kern, "Traction Motor Cooling Systems: A Literature Review and Comparative Study," in *IEEE Transactions on Transportation Electrification*, vol. 7, no. 4, pp. 2892-2913, Dec. 2021.
- [73] A. H. Mohamed, H. Vansompel and P. Sergeant, "An Integrated Modular Motor Drive With Shared Cooling for Axial Flux Motor Drives," in *IEEE Transactions on Industrial Electronics*, vol. 68, no. 11, pp. 10467-10476, Nov. 2021
- [74] J. Doerr, T. Attensperger, L. Wittmann, and al., "The New Electric Axle Drives from Audi", *. ATZ Elektron Worldw* 13, 16–23 (2018)