



Science Arts & Métiers (SAM)

is an open access repository that collects the work of Arts et Métiers Institute of Technology researchers and makes it freely available over the web where possible.

This is an author-deposited version published in: <https://sam.ensam.eu>
Handle ID: <http://hdl.handle.net/10985/9597>

To cite this version :

Thomas HENNERON, Stephane CLENET - Model-Order Reduction of Multiple-Input Non-Linear Systems Based on POD and DEI Methods - IEEE Transactions on Magnetics - Vol. 51, n°3, p.1-4 - 2015

Any correspondence concerning this service should be sent to the repository

Administrator : scienceouverte@ensam.eu



MODEL ORDER REDUCTION OF MULTI-INPUT NON-LINEAR SYSTEMS BASED ON POD AND DEI METHODS

T. Henneron¹ and S. Clénet²

¹L2EP/Université Lille1, Cité Scientifique - 59655 Villeneuve d'Ascq, France

²L2EP/Arts et Métiers ParisTech, Centre de Lille, 8 boulevard Louis XIV - 59046 Lille Cedex, France

The Proper Orthogonal Decomposition combined with the Discrete Empirical Interpolation Method is investigated in order to reduce a finite element model of a multi-input non-linear device. The non-linear reduced problem is solved using the Newton-Raphson method. The transient state of a three phase transformer with a variable load is studied with the proposed reduction method for different configurations of the supply voltage.

Index Terms— Discrete Empirical Interpolation Method, DEIM, Model Order Reduction, Non-linear Problem, Proper Orthogonal Decomposition, POD, Static fields.

I. INTRODUCTION

MODEL order reduction methods can be very effective in reducing the computational time of time-dependent numerical model. These methods consist in performing a projection of the solution of the full problem onto a reduced basis. The size of the equation system to solve can be then highly reduced. In the literature, the Proper Orthogonal Decomposition (POD) combined with the snapshot approach has been widely used to solve problems in engineering [1][2]. In the case of non-linear problems, the direct application of the POD requires additional calls to the full model cancelling out partially the advantages offered by the POD method in terms of memory requirements and calculation time. The Discrete Empirical Interpolation Method (DEIM) is an interesting way to avoid the calls to the full model [3][4]. In computational electromagnetics, the POD-DEIM technique with single input device has been used to study a single phase transformer [5]. The fixed point technique has been used to solve the non-linear problem which is very robust but has a poor speed of convergence. Even though, a significant speed up has been obtained, it can be expected to gain time by using more efficient non-linear solvers like the Newton-Raphson method. Besides that, it is well known that the accuracy of the reduced model vs the full model is directly related to the choice of the snapshots. In a single input problem, the choice of the snapshots is quite straightforward because the flux path (i.e. the field distribution) is almost the same whatever the value of the input. When the problem has multiple inputs, the flux paths can change a lot from a given input configuration to another. The snapshots should be chosen in order to be able to retrieve the field distribution corresponding to any input configurations. The snapshot determination becomes then more complex.

In this paper, we propose to apply the POD-DEIM approach to study a non-linear magnetostatic problem with multiple inputs solved using the Finite Element Method. The multiple inputs are the voltages of stranded inductors imposed by

external circuit equations. To solve the non-linear reduced model, the Newton-Raphson (NR) method will be also introduced. The full model is first presented. Secondly, the POD-DEIM approach is developed. Finally, a three phase transformer is studied with the proposed reduction method. The results obtained with the reduced models are compared in terms of accuracy and computation time with the full model.

II. NON-LINEAR MAGNETOSTATIC PROBLEM COUPLED WITH ELECTRIC CIRCUITS

Let us consider a domain D of boundary Γ ($\Gamma = \Gamma_B \cup \Gamma_H$ and $\Gamma_B \cap \Gamma_H = \emptyset$) (Fig. 1). The problem is solved on $D \times [0, T]$ with T the width of the time interval. The inductors are supposed to be stranded. The eddy current effect is neglected.

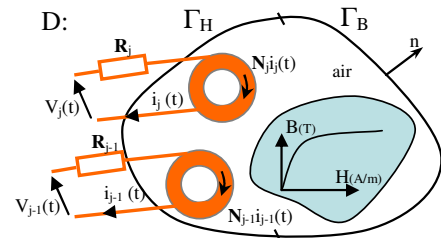

Figure 1. Non-linear magnetostatic problem coupled with electric circuits

In magnetostatics, the problem can be described by the following equations:

$$\text{curl } \mathbf{H}(\mathbf{x}, t) = \sum_{j=1}^{N_{st}} \mathbf{N}_j(\mathbf{x}) i_j(t) \quad (1)$$

$$\text{div } \mathbf{B}(\mathbf{x}, t) = 0 \quad (2)$$

$$\mathbf{H}(\mathbf{x}, t) = \nu_{(B)}(\mathbf{x}) \mathbf{B}(\mathbf{x}, t) \quad (3)$$

with \mathbf{B} the magnetic flux density, \mathbf{H} the magnetic field, \mathbf{N}_j and i_j the unit current density and the current flowing through the j^{th} stranded inductor, N_{st} the number of stranded inductors and $\nu_{(B)}(\mathbf{x})$ the magnetic reluctivity. For the ferromagnetic materials with a non-linear behaviour law, $\nu_{(B)}(\mathbf{x})$ depends on the field \mathbf{B} . To impose the uniqueness of the solution, boundary conditions must be considered such that:

$$\mathbf{B}(\mathbf{x}, t) \cdot \mathbf{n} = 0 \text{ on } \Gamma_B \text{ and } \mathbf{H}(\mathbf{x}, t) \times \mathbf{n} = 0 \text{ on } \Gamma_H \quad (4)$$

with \mathbf{n} the outward unit normal vector. In order to impose the voltage at the terminals of the stranded inductors, the following relations must be considered:

$$\frac{d\Phi_j(t)}{dt} + R_j i_j(t) = v_j(t) \quad \text{with } j=1, \dots, N_{st} \quad (5)$$

with R_j the resistance, Φ_j the flux linkage and v_j the voltage of the j^{th} stranded inductor. To solve the previous problem, the vector potential formulation is used. From (2), the potential \mathbf{A} is defined such that $\mathbf{B}(\mathbf{x},t) = \text{curl} \mathbf{A}(\mathbf{x},t)$ with $\mathbf{A}(\mathbf{x},t) \times \mathbf{n} = 0$ on Γ_B . To take into account the non-linear behavior of the ferromagnetic materials, the magnetic field $\mathbf{H}(\mathbf{x},t)$ is expressed by $\mathbf{H}(\mathbf{x},t) = v_{fp} \mathbf{B}(\mathbf{x},t) + \mathbf{H}_{fp}(\mathbf{B}(\mathbf{x},t))$ with v_{fp} a constant and $\mathbf{H}_{fp}(\mathbf{B}(\mathbf{x},t)) = (v_B(\mathbf{x}) - v_{fp}) \mathbf{B}(\mathbf{x},t)$ a virtual magnetization vector. According to (1) and (5), the equations to solve are:

$$\text{curl}(v_{fp} \text{curl} \mathbf{A}(\mathbf{x},t)) - \sum_{j=1}^{N_{st}} \mathbf{N}_j(\mathbf{x}) i_j(t) = -\text{curl}(\mathbf{H}_{fp}(\text{curl} \mathbf{A}(\mathbf{x},t))) \quad (6)$$

$$\sum_{j=1}^{N_{st}} \frac{d}{dt} \int_D \mathbf{A}(\mathbf{x},t) \cdot \mathbf{N}_j(\mathbf{x}) dD + R_j i_j(t) = v_j(t) \quad (7)$$

The fields $\mathbf{A}(\mathbf{x},t)$ and $\mathbf{N}_j(\mathbf{x})$ are discretised using edge and facet elements [6]. We denote $A_i(t)$ the line integral of \mathbf{A} along the i^{th} edge and N_e the number of edges. Then, applying the Galerkin method to (6) and (7), a system of differential algebraic equations is obtained under the form:

$$\mathbf{M} \mathbf{X}(t) + \mathbf{K} \frac{d\mathbf{X}(t)}{dt} = \mathbf{F}(t) - \mathbf{M}_{fp}(\mathbf{X}(t)) \quad (8)$$

with $\mathbf{X}(t)$ the vector of unknowns of size $N_{un} = N_e + N_{st}$ such that $(X_i(t))_{1 \leq i \leq N_e} = (A_i(t))_{1 \leq i \leq N_e}$ and $(X_i(t))_{N_e+1 \leq i \leq N_e+N_{st}} = (i_j(t))_{1 \leq j \leq N_{st}}$. \mathbf{M} and \mathbf{K} are $N_{un} \times N_{un}$ matrices and $\mathbf{F}(t)$ and $\mathbf{M}_{fp}(\mathbf{X}(t))$ $N_{un} \times 1$ vectors. To solve (8), an implicit Euler scheme is applied, the time step is denoted Δt . At each time step, the NR method is applied to solve the non linear problem. We denote $\mathbf{X}^j(t_i)$ the solution associated with the i^{th} time step and with the j^{th} iterative of the NR loop. The residual vector $\mathbf{R}[\mathbf{X}^j(t_i)]$ and the jacobian matrix $\mathbf{J}[\mathbf{X}^j(t_i)]$ are defined by:

$$\mathbf{R}[\mathbf{X}^j(t_i)] = \mathbf{F}(t_i) - \mathbf{M}_{fp}[\mathbf{X}^j(t_i)] - \mathbf{M} \mathbf{X}^j(t_i) - \mathbf{K} \frac{\mathbf{X}^j(t_i) - \mathbf{X}(t_{i-1})}{\Delta t}, \quad (9)$$

$$\mathbf{J}[\mathbf{X}^j(t_i)] = \mathbf{J}_{fp}[\mathbf{X}^j(t_i)] + \mathbf{M} + \frac{1}{\Delta t} \mathbf{K} \quad (10)$$

with Δt the time step, $\mathbf{J}_{fp}[\mathbf{X}^j(t_i)]$ the jacobian matrix corresponding to the vector $\mathbf{M}_{fp}[\mathbf{X}^j(t_i)]$. For each iteration of the NR loop, the following matrix system is solved:

$$\mathbf{J}[\mathbf{X}^j(t_i)] \Delta \mathbf{X}^j(t_i) = \mathbf{R}[\mathbf{X}^j(t_i)] \quad (11)$$

Finally, the vector $\mathbf{X}^j(t_i)$ is obtained by

$$\mathbf{X}^j(t_i) = \mathbf{X}^{j-1}(t_i) + \alpha \Delta \mathbf{X}^j(t_i) \quad (12)$$

with α a relaxation coefficient.

III. MODEL ORDER REDUCTION WITH DEIM-POD

In order to reduce the computation time required to solve the previous problem, the POD technique combined with the DEIM approach is applied [3][4]. The POD-DEIM method has been introduced in [5] to reduce a non-linear single input magnetostatic problem. The reduced problem has been derived directly from (8) and solved using the fixed point technic which is very robust but suffers from a slow convergence rate. In the following, to improve the convergence rate, we propose to reduce the non linear equation system (11) obtained by applying the NR method on (8). The reduced problem inherits then a faster speed of convergence from the full model (11).

A. Proper Orthogonal Decomposition

By applying the POD method, the vector $\mathbf{X}(t)$ is approximated in a reduced basis by a vector $\mathbf{X}_r(t)$ of size N_s ($N_s \ll N_{un}$). To determine a discrete projection operator Ψ such that $\mathbf{X}(t) = \Psi \mathbf{X}_r(t)$, the Snapshot approach is applied. The full model is solved for the first N_s time steps (snapshots) using the NR procedure. The snapshot matrix \mathbf{M}_s is defined by $\mathbf{M}_s = (\mathbf{X}^j)_{1 \leq j \leq N_s}$ with \mathbf{X}^j the solution $\mathbf{X}(t)$ at the j^{th} time step. Using a singular value decomposition form, the matrix \mathbf{M}_s is decomposed under the form:

$$\mathbf{M}_s = \mathbf{V} \Sigma \mathbf{W} = \sum_{i=1}^{N_s} \Sigma_i \mathbf{V}_i \mathbf{W}_i^t \quad (13)$$

with $\mathbf{V}_{N_{un} \times N_{un}}$ and $\mathbf{W}_{N_s \times N_s}$ orthogonal matrices of singular vectors and $\Sigma_{N_{un} \times N_s}$ the diagonal matrix of the singular values. Then, the operator Ψ is a selection of vectors of the matrix $\mathbf{V} \Sigma$ corresponding to the singular value higher than a given threshold fixed arbitrarily. According to (11), the reduced model to solve is:

$$\mathbf{J}_r[\mathbf{X}_r^j(t_i)] \Delta \mathbf{X}_r^j(t_i) = \Psi^t \mathbf{R}[\Psi \mathbf{X}_r^j(t_i)] = \mathbf{R}_r[\mathbf{X}_r^j(t_i)] \quad (14)$$

With the vector \mathbf{R} and the matrix \mathbf{J} given by (9) and (10) respectively. The solution of this reduced problem requires the calculations of the vector $\mathbf{M}_{fp}[\mathbf{X}^j(t_i)] = \Psi^t \mathbf{M}_{fp}[\Psi \mathbf{X}_r^j(t_i)]$ and the jacobian matrix $\mathbf{J}_{fp} = \Psi^t \mathbf{J}_{fp}[\Psi \mathbf{X}_r^j(t_i)] \Psi$. These calculations require to project the reduced solution $\mathbf{X}_r^j(t_i)$ back to the full problem (the term $\Psi \mathbf{X}_r^j(t_i)$) and to compute the two matrices which can be time consuming. To avoid this problem, the DEIM is applied which enables to approximate \mathbf{M}_{fp} and \mathbf{J}_{fp} above by calculating only a small number of their components.

B. Discrete Empirical Interpolation Method

From the solution of the full problem for the N_s first time steps, a $N_{un} \times N_s$ matrix \mathbf{S} of the $\mathbf{M}_{fp}(\mathbf{X}(t_i))$ ($1 \leq i \leq N_s$) is defined. The matrix \mathbf{S} is decomposed under the form given in (13) using a SVD. In the original DEIM, only the N_m most significant modes \mathbf{V}_i , which corresponds to the higher singular values Σ_i (see (13)), are stored to construct the projector operator \mathbf{U} . Applying a greedy algorithm, a matrix $\mathbf{P}_{N_{un} \times N_s}$ composed of N_s vectors of the identity matrix $\mathbf{I}_{N_{un} \times N_{un}}$ is defined from the indices of the most significant entries of \mathbf{U} .

The vector \mathbf{M}_{rfp} and the matrix \mathbf{J}_{rfp} can be then approximated by:

$$\begin{aligned} \mathbf{M}_{\text{rfp}}[\mathbf{X}_j(t_i)] &\approx \Psi^t \mathbf{U}(\mathbf{P}^t \mathbf{U})^{-1} \mathbf{P}^t \mathbf{M}_{\text{fp}}[\Psi \mathbf{X}_r^j(t_i)] \\ \mathbf{J}_{\text{rfp}}[\mathbf{X}_j(t_i)] &\approx \Psi^t \mathbf{U}(\mathbf{P}^t \mathbf{U})^{-1} \mathbf{P}^t \mathbf{J}_{\text{fp}}[\Psi \mathbf{X}_r^j(t_i)] \Psi \end{aligned} \quad (15)$$

According to (15), to determine the vector \mathbf{M}_{rfp} , the matrix $\mathbf{P}^t \mathbf{M}_{\text{fp}}[\Psi \mathbf{X}_r^j(t_i)]$ is calculated, this is equivalent to determine N_s entries of the vector $\mathbf{M}_{\text{fp}}[\Psi \mathbf{X}_r^j(t_i)]$. In the same way, the approximation of \mathbf{J}_{rfp} is determined by calculating only N_s vectors of the jacobian matrix \mathbf{J}_{fp} . The DEIM, by reducing dramatically the number of matrix entries of the full problem to be calculated, enables to speed up the solution of the non-linear reduced problem.

IV. APPLICATION

A 3D magnetostatic example, consisting of a three phase transformer supplied by sinusoidal voltages, is studied. The supply frequency is 50 Hz. Due to the symmetry, only one quarter of the transformer is modeled (Fig. 2-a). The non-linear magnetic behavior of the iron core is considered (Fig. 2-b). The 3D spatial mesh is made of 12636 nodes and 66382 tetrahedra. The number of time steps per period is 30.

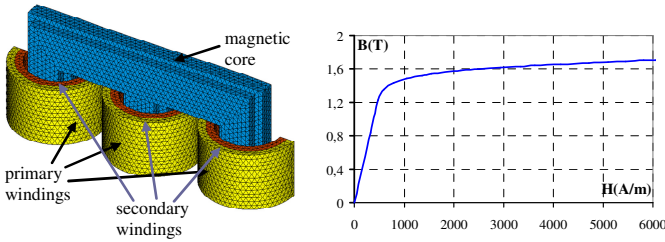

Figure 2. Example of application (a: geometry, b: non-linear curve of the core)

The aim of the study is to evaluate the accuracy of the POD-DEIM model for different values of supply voltage and the transformer load. For the first configuration, the typical tests at no load and in short circuit have been simulated. For the second case, the reduced model is tested on the whole operating range of the transformer by modifying the resistive load. For the third and last configuration, the POD-DEIM approach is evaluated for different voltage phase shifts. For all configurations, we compare the primary currents obtained from the reduced model with those obtained using the full model. The error ε_i is given by:

$$\varepsilon_i = \sum_{j=1}^3 \frac{\|\mathbf{i}_{j,\text{ref}} - \mathbf{i}_{j,\text{red}}\|_2}{\|\mathbf{i}_{j,\text{ref}}\|_2} \quad (16)$$

with $\mathbf{i}_{j,\text{ref}}$ and $\mathbf{i}_{j,\text{red}}$ the vectors of current values associated with the j^{th} primary winding at each time step obtained from the reference and the reduced model respectively.

A. First configuration

For the first configuration, the transformer is considered first at no load and second in short circuit. At no load, 65 periods ($T=1.3\text{s}$) are required to reach the steady state of the

primary currents. The number of snapshots has been increased step by step manually to construct an accurate reduced model. The POD-DEIM model requires 55 snapshots in order to obtain an acceptable error equal to 4% between the reduced and full models. Figures 3 and 4 present the evolution of the currents obtained from the full and reduced models for the beginning of the transient and at steady state. In our example, the currents in steady state are unbalanced due to the fact that the problem is not symmetric for the three phases. Figure 5 presents the edges selected automatically in the magnetic core by the DEIM approach. As expected, these edges are located in the saturated area. To determine the matrices of the reduced model, the entries of \mathbf{M}_{fp} and \mathbf{J}_{fp} (Section III.B) are only calculated for these corresponding edges. It means that if the i^{th} edge has been selected with the DEIM, the i^{th} entry of \mathbf{M}_{fp} and the entries of the i^{th} row of \mathbf{J}_{fp} are calculated which consists in calculating an integral on a small volume (the elements connected to the i^{th} edge).

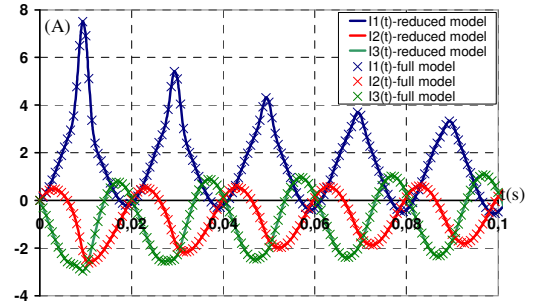

Figure 3. Evolution of the currents obtained from the full and reduced models at the beginning of the transient state

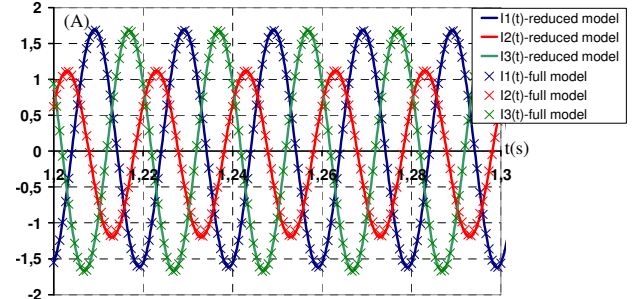

Figure 4. Evolution of the currents obtained from the full and reduced models at the steady state

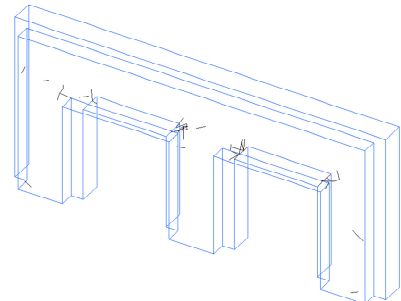

Figure 5. DEIM edges in the magnetic core

In terms of computation time, the reference model requires 210min and the reduced model 2.7min which corresponds to a speed up of more than 77. In short circuit, the time interval is $T=0.04\text{s}$. The POD-DEIM approach requires 10 snapshots in

order to obtain an error close to 3% and the time speed up is 68. The computation time for the reduced model does not take into account the computation time required for the snapshots.

B. Second configuration

For the second configuration, the idea is to evaluate a reduced model on the whole operating range of the load of the transformer. In electrical engineering, typical tests are proposed in order to determine the parameters of an equivalent circuit which enables to model the electrical device on the whole operating range. The idea is to apply the same approach with POD by combining snapshots obtained by simulating these typical tests. In our example, the snapshots obtained from the typical tests at no load and in short circuit (Section IV-A) are then merged in the same snapshot matrix. Then, the POD-DEIM approach is applied. Figures 6 and 7 show the evolutions of the primary currents obtained from the full and reduced models for three values (5 and 10 Ω) of the load resistor connected to the secondary windings. For all cases, the error is close to 0.6%. The ratio of computation time between the full and reduced models is then equal to 16.

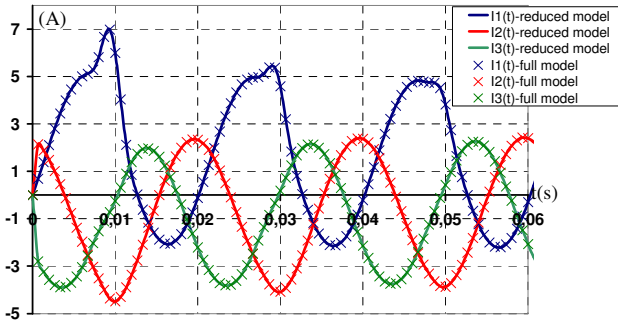

Figure 6. Evolution of the currents obtained from the full and reduced models for a load resistor equal to 5 Ω

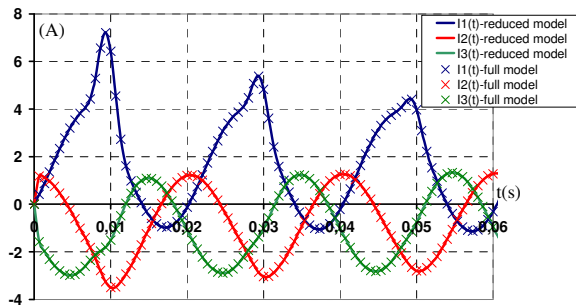

Figure 7. Evolution of the currents obtained from the full and reduced models for a load resistor equal to 10 Ω

C. Third configuration

For the third configuration, the idea is to evaluate a reduced model for different phase shift φ of the phase 1. The load resistor is 10 Ω . The full model is solved for the three extreme cases of the phase ($\varphi=0, 2\pi/3$ and $4\pi/3$). For each simulation, 55 snapshots are extracted. All snapshots are merged in a unique matrix of snapshots. Then, the POD-DEIM approach is applied. In order to limit the size of the projector Ψ , the SVD (equation (13)) is truncated. Figure 8 and 9 present the evolutions of the primary currents obtained from the full and reduced models for two values of the phase φ ($\pi/6$ and $5\pi/6$).

The error is equal to 5.4% and 2.6% respectively. The ratio of computation time between the full and reduced models is close to 9.

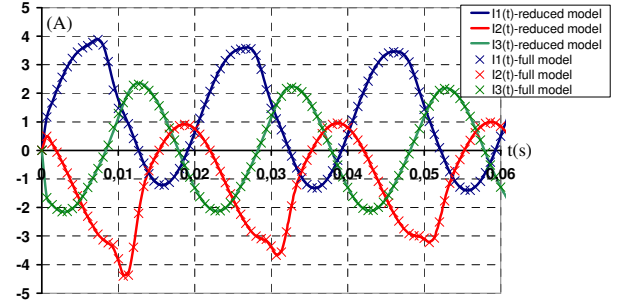

Figure 8. Evolution of the currents obtained from the full and reduced models for a phase equal to $\pi/6$

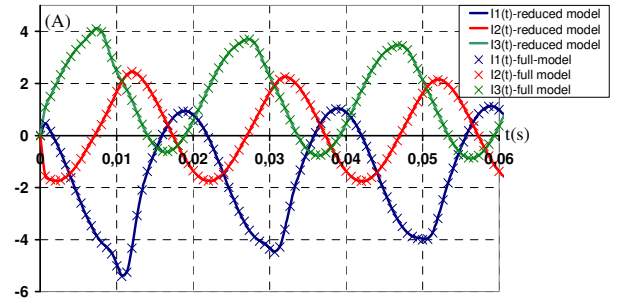

Figure 9. Evolution of the currents obtained from the full and reduced models for a phase equal to $5\pi/6$

V. CONCLUSION

The Proper Orthogonal Decomposition combined with the Discrete Empirical Interpolation Method has been developed with a FEM vector potential formulation in order to solve a 3D non-linear magnetostatic problem coupled with electric circuits. The Newton-Raphson approach has been introduced to increase the convergence speed of the non linear loop. From the application example, the POD-DEIM model enables to reduce dramatically the computation time while obtaining good precision. It has been shown that it was possible to construct an efficient reduced model from snapshots extracted to different simulations such that a reduced model valuable on the whole operating range from the typical tests at no load and in short circuit.

REFERENCES

- [1] J. Lumley, "The structure of inhomogeneous turbulence", *Atmospheric Turbulence and Wave Propagation*. A.M. Yaglom and V.I. Tatarski., pp. 221–227, 1967.
- [2] L. Sirovich, "Turbulence and the dynamics of coherent structures", *Q. Appl. Math.*, vol. XLV, no. 3, pp. 561–590, 1987.
- [3] M. Barrault, N. C. Nguyen, Y. Maday, and A. T. Patera, "An "empirical interpolation" method: Application to efficient reduced-basis discretization of partial differential equations", *C. R. Acad. Sci. Paris*, vol. 339(9), 2004, pp. 667–672, 2004.
- [4] S. Chaturantabut and D. C. Sorensen, "Nonlinear Model Reduction via Discrete Empirical Interpolation", *SIAM J. Sci. Comput.*, vol. 32(5), pp.2737–2764, 2010.
- [5] T. Henneron, S. Clénet, "Model Order Reduction of Non-Linear Magnetostatic Problems Based on POD and DEI Methods", *IEEE Trans. Mag.*, vol. 50(2), 2014.
- [6] A. Bossavit, "A rationale for edge-elements in 3-D fields computations", *IEEE Trans. Magn.*, vol. 24(1), pp 74-79, 1988.