



Science Arts & Métiers (SAM)

is an open access repository that collects the work of Arts et Métiers Institute of Technology researchers and makes it freely available over the web where possible.

This is an author-deposited version published in: <https://sam.ensam.eu>
Handle ID: <http://hdl.handle.net/10985/16979>

To cite this version :

Katia LUPINETTI, Franca GIANNINI, Marina MONTI, Jean-Philippe PERNOT - Identification of functional components in mechanical assemblies - Procedia CIRP - Vol. 60, p.542-547 - 2017

Any correspondence concerning this service should be sent to the repository

Administrator : scienceouverte@ensam.eu



27th CIRP Design 2017

Identification of functional components in mechanical assemblies

Katia Lupinetti^{a,b,*}, Franca Giannini^a, Marina Monti^a, Jean-Philippe Pernot^b

^a*Istituto di Matematica Applicata e Tecnologie Informatiche - Consiglio Nazionale delle Ricerche, Via De Marini 6, 16149, Italy*

^b*LSIS Laboratory UMR CNRS 7296 - Arts et Métiers ParisTech, 2 Cours des Arts et Métiers, 13617 Aix En Provence, France*

* Corresponding author. Tel.: +39 010 64 75 570. E-mail address: katia.lupinetti@ge.imati.cnr.it

Abstract

Manufactured products with different purposes often include similar mechanisms to realize movements required to satisfy specific functionalities. An automatic identification of common mechanisms in assembly models would be a valuable support for analysing or reusing existing solutions during the design process. In this paper, we present a first step towards the identification of mechanism for motion transformation, focusing on those containing non-linear bearings. In particular, we describe methods for non-linear bearing identification within assemblies, which allow axial rotation, as a shaft rotation. The main novelty concerns the capability of detecting bearings independently on their design level of details, i.e. represented as assemblies of their constituent components or idealized by their external 3D shape outline. The proposed method is based on a set of rules defined according to a priori knowledge and exploits implicit information automatically extracted from the assembly description and can be extended to other types of mechanism.

© 2017 The Authors. Published by Elsevier B.V. This is an open access article under the CC BY-NC-ND license (<http://creativecommons.org/licenses/by-nc-nd/4.0/>).

Peer-review under responsibility of the scientific committee of the 27th CIRP Design Conference

Keywords: Component classification; Assembly retrieval; Multi-resolution;

1. Introduction

Functional properties about assembly components are valuable in several phases during Product Development Process (PDP), for example to simulate the behavior of the whole assembly during the finite element (FE) analysis. In this environment, the geometric representations of assembly components are not sufficient and their functional and kinematic data are necessary [1]. Indeed, a component can be simplified for the FE analysis according to its function. While the kinematic interferences can be deduced analyzing technology information and functional data, since kinematics contributes to the definition of the mechanical functions of components.

Functional information can also be used to speed up the design process, allowing the reuse of previous solutions and knowledge. In the initial design stage, designers often seek for components without strict constraints on the shape but with

defined properties. In this kind of exploration, component functionalities play a central role for the component search and the access to the associated data, as failure reports, customer specifications or reference norms.

Even if, functional information of components is crucial and is usually recorded through company-specific codes, anyhow most of the information is lost at the end of the PDP and is not effectively handled in most of the CAD and Digital Mock-Up (DMU) systems. DMU tools were initially used for manufacturing purposes offering a digital representation of an assembly model and its components. Currently they are widespread employed in several industrial fields as automotive, aerospace and naval [2] and are used for many purposes to virtually examine the assembly. However, the DMU product model is usually reduced to a collection of parts correctly located in the 3D space, without any mechanical function information [1].

Nowadays, many efforts are devoted to improving the CAD model description and the development process to augment the stored knowledge and limit the information loss during the communication among the various processes. Anyhow, a big amount of models already exists, where functional information are missed, thus methods are needed to extract it.

In this perspective, in this paper we address the automatic identification of mechanisms, through the detection of recurrent composing components. Here we focus on the mechanisms for motion modifications, which take a power source as input and transforms it varying the power or the movement direction. For instance, gearboxes take rotation power to speed up and to slow down the movement by exploiting gears of different radius; turbines take energy from a fluid flow and convert it into mechanical energy.

There exist several ways to develop a motion modification mechanism, but some standard elements and configurations are mandatory in its design. We exploit these rules for characterizing and then for identifying this mechanism in assembly models. The main problem of its characterization is that some standard parts (as screws, nuts, bearings, gears or circlips), generally, are not manufactured by designers but imported from supplier catalogues or idealized. This tendency may affect the consistence of the model representation, thus methods able to deal with undetailed component descriptions are needed.

In this paper, we face the identification of rolling bearing components, which provide rotation around a fixed axis. They are very common in the mechanisms and may have different constituting elements and different types of representation: detailed as an assembly of its constituent components, as well as simplified as a single part. Identifying bearings, embedded in an assembly model regardless the used representation, is a first step towards the functional characterization of the overall assembly.

The identification of components with different function may require a completely different characterization, i.e. different rules need to be defined for their identification. For example, linear bearing functionality is different from the rotary one and then it has to be treated as a different component.

The rest of the paper is organized as follows; Section 2 presents related works on assembly and part functionality detection. Section 3 describes the mechanisms, which the paper focuses on illustrating the related representation characteristics. Section 4 illustrates the proposed method to classify its components. The results are shown in section 5 and section 6 ends the paper providing some concluding remarks and future steps of the presented research.

2. Related works

The link between the product functionality and its shape is an open issue in literature, since several shapes can achieve the same functionality as well as same shape can perform multiple functionalities according to how they are organized in the whole assembly.

The work of Foucault [2] offers an exhaustive overview on the difficulties in the recovery of technology and functional information in the DMU. The main issue concerns that, according to company methodology or personal criteria, designers use different approaches to represent idealized parts and to define the sub-assembly structure

To avoid some difficulties associated with simplified descriptions, [2] proposes a standard process for the simplification of the model shape.

Shahwan et al. [3, 4] proposed an approach to achieve functional information starting from component shapes to prepare the model for FE simulation. The first step of their work aims to find out geometric interferences and use them to determinate functional interferences in a following reasoning phase. The method uses only geometric description of the models and supposes that it has no design errors and holds conventional representation. The main limitation of this method is the complete entrustment in the design methodologies. Moreover, it identifies functional designations, as cap-screw, tubular rivet, gear, but not component's functions (as fastening or pivoting point)

The extension of this work [5] uses mechanical equilibrium state analysis as physical low to each component for assigning at geometric interfaces only one functional interface. Anyway, it just considers part and not sub-assembly components, and the approach is semi-automatic, as it needs user help for identifying the start and the end of the kinematic chain in the assembly model.

Roy and Bharadwai [6] illustrate how part functions are associated with the conceptual design phase of new products. From the functionality of a part, it is hard obtaining details about the geometry of a part: their work investigates the relationships between the function, the behavior (i.e. the results of iterations of a part with other parts in an assembly) and the geometry of a part. They propose a methodology for the representation of the behavior of parts as functional relationships related to the faces of the part.

Still in the context of conceptual design, Roy et al. [7] propose a set of generic definitions for some components to lead the design process and derive artifacts (i.e. assembly components) from functional requirements. Generally, a function can be achieved through different components and these may have different behavior considering their interaction with other components present in the assembly model. Offering a representation for product specification, functional requirements and artifact behavior, they detail a design methodology to design an artifact that satisfies the product specification.

Even if these two works address the bond between product functionality and their shape, they offer methodologies only in one direction, from function to design. Thus they can be applied only to new designs; conversely, we propose to extract functional information from an existing design to enrich DMU systems for already available models and despite the adopted design process.

3. Mechanism representation in CAD models and related issues

In this section, we briefly illustrate the considered type of mechanism, its components and how they interact.

Fig. 1. shows an example of the considered type of mechanism. Generally, an input power is transmitted along a *shaft*. Some *gears* of different dimensions are located on it to cause the motion transformation. A rotation motion of the mechanism is possible thanks to the presence of *rolling bearings* that reduce the friction. At the end, *circlips* and *spacers* block bearing lateral movements.

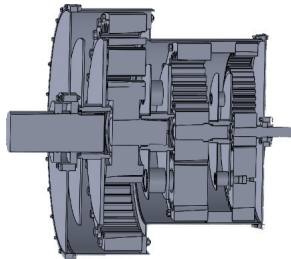

Fig. 1. Example of mechanism for motion transformation

The mentioned components arranged in a specific way are always present in mechanisms of this type. Thus, the first step towards their identification is the detection of their components and their mutual location and interaction. This task is difficult since these components can be represented in different ways and there may be errors in their representations caused by loss of information in CAD models during some phases of the PDP [2]. An overview of these issues is presented in the next sub-section.

3.1. Representation issues

During the product development process, designers, according to their purposes, can choose to fully detail some components and to simply sketch others. Fig. 2. depicts two gears modelled at different level of details. The representation in Fig. 2(a) provides the precise shape of the gear, while the representation in Fig. 2(b) gives an abstracted shape, which by itself is not sufficient to indicate what the component is. The meaning of this last shape can only be deduced from its usage in the assembly model; in fact, this simple shape can correspond to several objects, such as spacers or other simplified components.

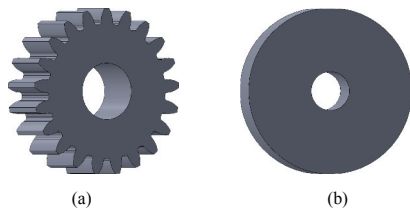

Fig. 2. Two representations at different level of detail of the same part:
(a) Detailed gear; (b) Simplified gear

More complex parts constituted by multiple elements can be also described with different representations, e.g. as a unique single part as well as an assembly of several parts/components. Fig. 3. shows some possible representations for a bearing. Fig. 3(a) shows a bearing modeled as a fully detailed assembly where all its parts are represented. One of its possible simplifications is illustrated in Fig. 3(b), where the balls are collapsed in a single cylindrical shaped part. Another kind of simplification is shown in Fig. 3(c): in this case, all its elements are merged into a single part and the bearing preserves its external shape. The last representation is the most degenerated, reduced to a simple cylinder with a central hole; it has no expressive power and looks like the simplified gear in Fig. 2(b).

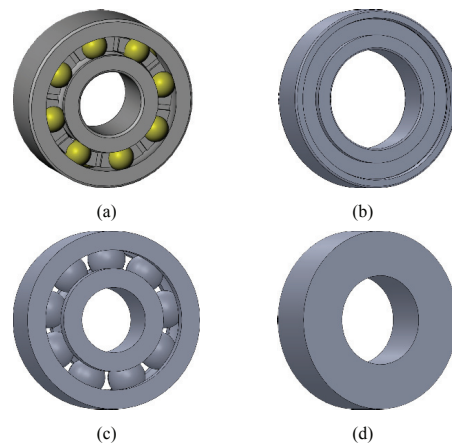

Fig. 3. Different representations of a bearing component at different resolutions: (a) Detailed assembly; (b) Simplified assembly; (c) Detailed part; (d) Simplified part

Another important issue relating to the CAD representation of assembly models is the possible absence of constraints between the components. Generally, CAD systems provide capabilities to easily specify and store the relative position and relation between components, but these data may become invalid during modification and model exchange. Moreover, components may be positioned in the 3D space instead of explicitly putting them in relation with the other parts in the assembly. Unfortunately, this practice often generates volumetric interferences that should not exist, altering the nature of the interaction between components.

4. Bearing classifications

Considering the many possible representations for a given component in an assembly model, component classification is not an easy task. In this section, according with the mechanism we address, we focus on the classification of rolling bearings, which allow an axial rotation on a shaft, considering the possible different representations, by exploiting some characteristics always valid despite the specific bearing type.

There exist many kinds of rolling bearings, according to the effort they must support. In general, bearings present several occurrences of elements, called balls if spherical or rollers if conical or cylindrical, arranged in different ways in a circular pattern.

Ball bearings are the most common type because they can support both radial and axial loads. Anyway, their load capacity is not very elevated due to the very small contact between the balls and the raceway.

Roller bearings can support radial or thrust efforts and the roller can be disposed in single or multiple rows. In the considered type of mechanisms, mainly three main types of roller bearings exist: cylindrical, thrust, and tapered. In the first type, the cylindrical rollers are in linear contact with the raceways. They have a high radial load capacity and are suitable for high speeds. Thrust roller bearings are used to support axial loads and shock loads, and they do not support radial load. Tapered roller bearings use conical rollers. They are capable of taking high radial loads and axial loads in one direction [8].

Despite the type, a bearing is always defined by four components: a *set of balls/rollers*, secured by a *cage*, and an *inner and outer ring*, which enclose the rollers. The cage has a shape extremely variable (without considering the different level of details in its representation) and this produces different kind of interaction with the rollers.

As mentioned before, in the assembly models these elements are normally reduced to components positioned in the space, without any placement constraint information. For this reason, the starting input for our classification is a pure B-rep of the assembly. The classification is based on the shape of the elements and on their mutual interaction, as described in the next subsections.

4.1. Classification of bearings represented as assemblies

When the bearing is fully detailed, we assume that it corresponds to a sub-assembly in the whole assembly model. For its detection, we focus on the repeated elements and on the inner and outer rings ignoring the cage having too variable shape.

Using a-priori engineering knowledge, we define some general rules valid for all the considered bearings exploiting implicit information deduced from the position of the components.

The first characteristic is the presence of repeated elements (balls or rollers) arranged in a circular pattern. We consider two elements as *repeated* either if they represent a different instance of the same part or if they have the same shape. Details on the method adopted for the detection of patterns of repeated elements in assemblies are given in [9].

However, the presence of patterns of repeated elements and candidate inner and outer rings is not a sufficient condition to assess the existence of a bearing. We need also to take into consideration the interaction among these elements: balls (rollers) are always in contact by a vertex (a line) with the inner and outer rings, see Fig. 4.

Due to position or tolerance problems, it may happen that the balls volumetrically intersect the ring(s). Since we are

considering rigid metallic objects, this configuration should not exist. To overcome this problem, we assume that the contact between a sphere and another part is always a vertex.

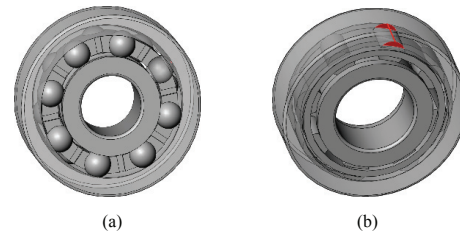

Fig. 4. Implicit information (a) Repetition of spheres with vertex contacts; (b) Repetition of cylinders with face and line contacts

Similarly, positioning errors of the rollers, like in the configuration in Fig. 4(b), produce interferences that can be solved by analyzing the cylindrical surfaces in the resulting intersection volume. See [10] for further details on the method for the detection of the contacts between parts the assembly.

Sometimes in engineering practice, patterns of balls/rollers are represented at a higher level of abstraction as a unique part with toroidal or cylindrical shape. This unique part is in contact by a toroidal or cylindrical surface with the inner and outer rings. Generally, this simplified description involves only three parts (inner and outer rings and the conglomerated balls); however, cases with other auxiliary parts can be found. Since these parts are supplementary and do not establish any peculiar characteristic, they are not included in our identification criteria.

In our recognition process, each assembly model is converted into a graph structure, where each node corresponds to a part, if not involved in a pattern, or to a set of parts belonging to the same pattern; arcs represent the contacts between parts. The data extracted to characterize a bearing are stored as attributes of the nodes and arcs of the graph.

The identification of bearings is then achieved through a sub-graph matching between the graph of the assembly model and a set of graphs that contain the attributed nodes and arcs characterizing the bearing. See [9] for further details on the adopted matching method. Fig. 5. shows two of the graphs used for the sub-graph matching. In Fig. 5(a) the yellow node identifies all the balls that form the circular pattern. In this case, the dashed arcs identify the multiple contacts between the balls and the rings. While Fig. 5(b), refers to the more abstracted version, thus the yellow node is associated with a single part of the CAD model and the arcs represent a single surface contact.

4.2. Classification of bearings represented as parts

When a bearing is modeled as a single part, as discussed in section 3, its shape specification is not sufficient for its classification. In this case, we need to use also engineering knowledge related to the position and relations of bearings with the other components forming the mechanism.

Bearing components usually are in contact with a shaft by the internal ring and a housing by the external ring. However,

there exist cases where the external ring has grooves to allocate inserts, which avoid lateral movement. Therefore, the bearing has multiple contacts with the housing.

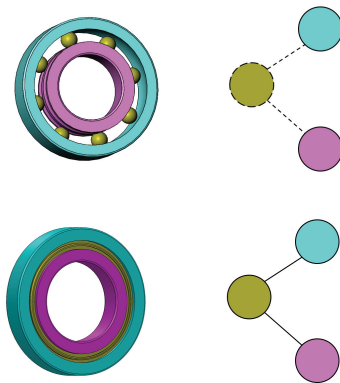

Fig. 5. Abstract bearing definition (a) Bearing characteristics; (b) Graphs representing the bearings

The candidate bearings are parts that have exactly one through hole, i.e. genus 1, and exactly two cylindrical surface contacts with two different components, C_i and C_j . To manage possible multiple contacts due to the presence of a groove, we introduce the concept of equivalent contacts. Two cylindrical contacts between the same two components are equivalent if and only if the associated surfaces are the same (same radius and same axis). Thus, equivalent contacts are counted only once. Moreover, components in charge of avoiding lateral movement of the bearing (as snap rings) can be located in the grooves, enlarging the number of components with which bearings are in contact. Our approach skims possible snap rings before the process of bearing identification for neglecting them in the computation of components in contact with the candidate bearings.

As last step, since the shaft and the housing are not directly in contact, we check that the two parts C_i and C_j verify this condition.

Since this representation is very coarse and the same conditions on the contacts can occur for other idealized elements, the described process allows only detecting parts which are highly candidate to be bearings and thus the final result is only an indication of the possible presence of a specific mechanisms.

5. Implementation and results

A prototype for the bearing identification was developed using .NET platform and exploiting the API of the CAD modeler SolidWorks. The procedure takes as input an assembly model in STEP format (ISO 10303-203 and ISO 10303-214).

The validation of the proposed characterization was carried out on both assembly models created by engineering students and real industrial assembly models accessible on the online repository of Traceparts [11] and GrabCad [12]. It allows us

to prove that the proposed characterization supports different kinds of representation and is able to deal with some possible model imprecisions.

Fig. 6 shows the components identified as bearing in some of the tested models. In the reported results, our approach identifies 58 over 63 bearings and there are no false-positives. Almost all the bearings in the assembly models were recognized; the not recognized bearings (depicted in red) are not represented as sub-assembly in the whole model or present other kinds of volumetric intersection, which we do not manage yet in the current implementation. Anyway, these limitations affect very few cases.

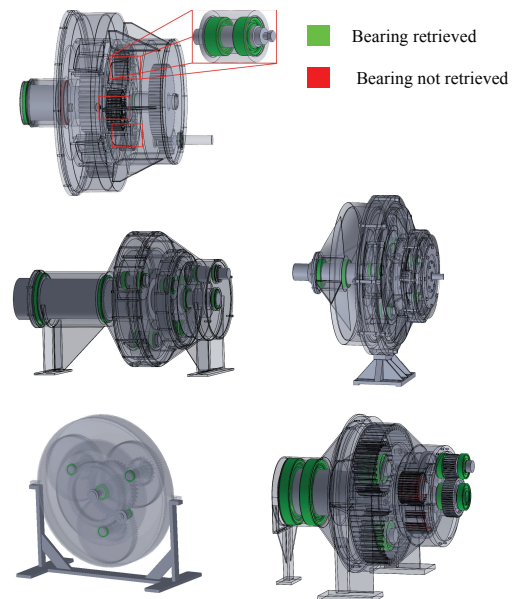

Fig. 6. Identification of bearings represented as assembled components.

Fig. 7 shows some of the results obtained by the verification of the presence of possible bearings modeled as a unique part. For those models, the approach identifies 67 over 69 bearings. Differently from the previous case, there are 10 false-positives (depicted in blue). We notice that our approach identifies cushions, seals, O-rings, ring-blocks or washers as bearing. Cushion and bearing are used in assembly model to reduce the friction between components, thus it is understandable that they satisfy the same conditions. The few other components with a different purpose, which are identified as bearings, present the same contact configuration with the adjacent components. To distinguish bearings from those components, we have to further extend the component characterization to the surrounding context, not limiting it to the contacts between parts, but also involving other layers, as the mutual positioning of the components.

Considering the coarseness of the involved representation, the proposed criteria are adequate to retrieve a good percentage of the bearings present in the assembly model: the not retrieved ones are affected from inaccuracies of the part position in the original assembly models.

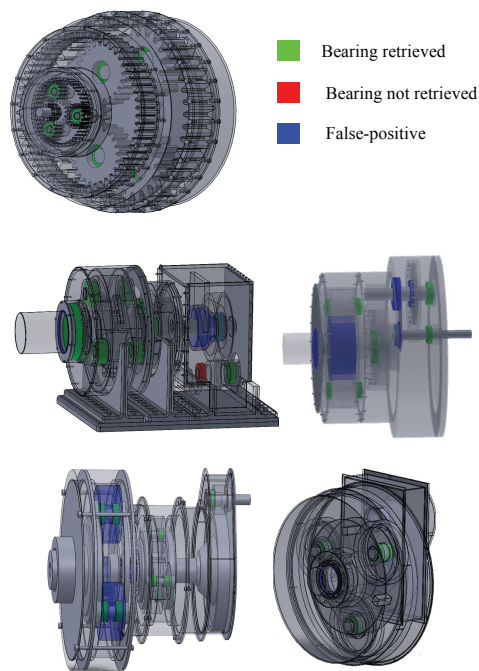

Fig. 7. Identification of bearings represented as parts.

6. Conclusions

In this paper, we illustrated a method to identify specific components, i.e. rolling bearings, in assembly models independently on their representation. The adopted characterization of non-linear bearings represents the first step towards the automatic functional characterization of CAD components in assemblies.

The proposed method exploits shape information as well as the component/part arrangements and contacts in the assembly model. The principal issues regard the multiplicity of types of the considered components, the variability in their description, but also the lack of information in the assembly. In fact, the necessary information for the bearing identification is not present or annotated in the CAD model, thus methods for its automatic extraction have been developed [9] and used.

A simplified part can represent different components that cannot be distinguished without considering the surrounding context. In our approach, we consider a first level of context by exploiting the contacts between the components. In case of bearings represented as assemblies, the method provides excellent results. While, in case of bearings represented as parts, a deeper characterization of the surrounding context is needed, taking into consideration also the mutual positioning of the components.

Future works will focus on the analysis and formalization of the conditions that can discriminate the correctly recognized bearing configurations from the inappropriate ones.

We intend to exploit the ability of identifying candidate bearings in an assembly model for recognizing other components of the described mechanism (as the shaft and the gears) whose shape can be idealized making very challenging their identification too. At the same time, the identification of other components, can confirms the correct classification of the detected potential bearings if their reciprocal setting satisfy the conditions from the common engineering design practice. For the identification of the other types of idealized components, specific ad hoc rules based on a priori engineering knowledge will be defined.

On the contrary, the method applied for the characterization of the assembly constituting the bearings is general and can also be applied for the example-based retrieval of sub-assemblies in CAD model.

References

- [1] Boussuge F, Léon J-C, Hahmann S, Fine L. An analysis of DMU transformation requirements for structural assembly simulations. In B.H.V. Topping, (editor), Proceedings of the Eighth International Conference on Engineering Computational Technology. Dubronik, Croatia, September, Civil-Comp Press, Stirlingshire, Uk, Paper 30, 2012 doi:10.4203/ccp.100.30
- [2] Foucault G, Shahwan A, Léon, J-C, Fine L. What is the content of a DMU? Analysis and proposal of improvements. AIP-PRIMECA 2011 - Produits, Procédés et Systèmes Industriels: intégration Réel-Virtuel, Mar 2011, Le Mont Dore, France. 2011.
- [3] Shahwan A, Foucault G, Léon J-C, Fine L. Towards Automated Identification of Functional Designations of Components Based on Geometric Analysis of a DMU. GTMG2011 - 12èmes Journées du Groupe de Travail en Modélisation Géométrique, Mar 2011, Grenoble, France. p.61.
- [4] Shahwan A, Léon J-C, Foucault G, Trlin M, Palombi O. Qualitative behavioral reasoning from components' interfaces to components' functions for DMU adaption to FE analyses. Computer-Aided Design 45.2, 2013, p. 383-394.
- [5] Shahwan A, Foucault G, Léon J-C, Fine L. Deriving functional properties of components from the analysis of digital mock-ups. Engineering Computations, Emerald, 2014; p.16.
- [6] Roy U, Bharadwaj B. Design with part behaviors: behavior model, representation and applications. Computer-Aided Design 34.9, 2002; p. 613-636.
- [7] Roy U, Pramanik N, Sudarsan R, Sriram R.D, Lyons K.W. Function-to-form mapping: model, representation and applications in design synthesis. Computer-Aided Design, Volume 33, Issue 10, September 2001; p. 699-719, ISSN 0010-4485, [http://dx.doi.org/10.1016/S0010-4485\(00\)00100-7](http://dx.doi.org/10.1016/S0010-4485(00)00100-7).
- [8] <http://www.nsk.com/services/onlinecatalog/>
- [9] Lupinetti K, Chiang L, Giannini F, Monti M, Pernot J-P. Regular patterns of repeated elements in CAD assembly model retrieval. CAD'16 conference, Vancouver, Canada, 2016 June 27-29, Proceedings of CAD'16, pag: 147-151.
- [10] Lupinetti K, Giannini F, Monti M, Pernot J-P. Automatic Extraction of Assembly Component Relationships for Assembly Model Retrieval. Procedia CIRP, Volume 50, 2016, p. 472-477, ISSN 2212-8271, <http://dx.doi.org/10.1016/j.procir.2016.04.148>.
- [11] <https://www.tracepartsonline.net>
- [12] <https://grabcad.com/>