



### **Science Arts & Métiers (SAM)**

is an open access repository that collects the work of Arts et Métiers Institute of Technology researchers and makes it freely available over the web where possible.

This is an author-deposited version published in: <https://sam.ensam.eu>  
Handle ID: [.http://hdl.handle.net/10985/22435](http://hdl.handle.net/10985/22435)

#### **To cite this version :**

Antonin RIBIERE, Ngac Ky NGUYEN, Eric SEMAIL, Christophe ESPANET - Comparison of five-phase, six-phase and seven-phase fault tolerant electric drives - 2022

Any correspondence concerning this service should be sent to the repository

Administrator : [scienceouverte@ensam.eu](mailto:scienceouverte@ensam.eu)



# Comparison of five-phase, six-phase and seven-phase fault tolerant electric drives

Antonin Ribière<sup>1,2</sup>, Ngac-Ky Nguyen<sup>1</sup>, Eric Semail<sup>1</sup>, Christophe Espanet<sup>2</sup>

<sup>1</sup> Univ. Lille, Arts et Metiers Institute of Technology HESAM Université, Centrale Lille, Junia, ULR 2967 – L2EP, F-2500 Lille, France

<sup>2</sup> Moving Magnet Technologies; 1 rue Christiaan Huygens, F-25000 Besançon, France

antonin.riberie@ensam.eu, ngacky.nguyen@ensam.eu, eric.semail@ensam.eu, christophe.espanet@movingmagnet.com

**Abstract**—Automotive industry is evolving towards more fault-tolerant actuators to fulfill future autonomous vehicles requirements. Critical applications such as steering or braking have to resist to fault occurrences while being low cost due to mass production market. Considering these two criteria, multiphase electric drives offer a good tradeoff between increasing the degrees of freedom and limiting system oversizing. This paper proposes to compare three multiphase electric drives for electro-hydraulic power steering for trucks: a five-phase machine and a six-phase machine both fed by a full bridge inverter (FBI), and a seven-phase machine fed by a standard half-bridge inverter (HBI). Several comparison criteria are considered in the meantime: motor, electronics, control and manufacturing parameters. Some of criteria are obtained from finite-element analysis (FEA), while others are derived from analytic formula or dynamic simulations. Criteria are evaluated for each drive and then results are discussed. In the given low-voltage high-current application, H-bridge inverter topology seems to be a promising solution. Both five-phase and six-phase present similar results. However, six-phase drive could be more interesting, as it could be brought close to standard three-phase solutions and adapted to dual-lane supply.

**Keywords**— multiphase machine, multiphase drive, open-end winding, fault tolerant control, automotive steering

## NOMENCLATURE

Notation	Definition	Notation	Definition
EHPS	Electro-Hydraulic Power Steering	$P_{\text{stat}}$	Motor stator losses, including copper and iron losses
EMI	Electro-Magnetic Interferences	TIPM	Tangential Internal Permanent Magnets
FBI	Full-Bridge Inverter	$P_{\text{stat}}$	Motor stator losses, including copper and iron losses
FEA	Finite Element Analysis	1OPF	One Open Phase Fault
FT	Fault Tolerant	2OPF	Two Open Phase Fault, if not specified it is the configuration that induces more constraints on the drive
HBI	HalfBridge Inverter	2OPF-ap	Two adjacent Open Phase Fault
$I_{\text{rms,max}}$	Maximum rms phase current (after fault occurrence)	2OPF-nap	Two non-adjacent Open Phase Fault
$k_m$	Motor constant, ration between electromagnetic torque and root square of copper losses	$\Delta T$	Torque ripple

Notation	Definition	Notation	Definition
$k_{\text{oc\_OPF}}$	Ratio between maximum rms phase currents after 1OPF and healthy condition	$\Delta T_{1\text{OPF}}$	Torque ripple after one open phase fault, with MTPA reconfiguration control
$M_{\text{Cu}}$	Copper mass	$\Delta T_{2\text{OPF}}$	Torque ripple after two open phase faults, with MTPA reconfiguration control; worst case is considered
$M_{\text{mag}}$	Permanent magnets mass	$\Delta T_{\text{healthy}}$	Torque ripple in healthy state, without any faults
$n_{\text{CLC}}$	Total number of current close-loop controllers	$\Omega$	Motor mechanical speed
$n_{\text{tr}}$	Total number of transistors in the inverter power stage	$\vec{i}^{\text{ref}}$	Current references vector
PCB	Printed Circuit Board	$T_{\text{em}}^{\text{ref}}$	Electromagnetic torque reference
$P_{\text{Cu}}$	Motor copper losses	$\vec{e}$	BEMF vector
$P_{\text{invTot}}$	Inverter total losses, including both conduction losses in transistors and diodes, switching losses and recovery losses	$\vec{e}$	Speed-normalized BEMF vector (BEMF vector divided by mechanical speed)
$P_{\text{rot}}$	Motor rotor losses, including permanent magnets and iron losses	$\vec{e}_{\text{OPF}}$	Speed-normalized BEMF vector after OPF, with only the remaining healthy phases

## I. INTRODUCTION

The demand for safety actuators in the automotive is growing with the trends towards partially and full autonomous vehicles. For instance, braking and steering are demanding applications in terms of reliability as minimum functional should be kept, whatever the circumstances among ISO26262 standard. As a consequence, standard three phase drives are no more suitable for fault-tolerant application. After an open phase fault (OPF), the motor cannot produce a constant torque anymore. Redundancy could be a solution. However, using two actuators rather than one is not effective in terms of integration and cost. On the contrary, multiphase drives allow fault-tolerant (FT) capability. A higher number of phases increases degrees of freedom while being competitive in terms of integration. These drives have been already investigated in other industries such as ship propulsion or aircrafts [1][2]. Another way to increase the

degree of freedom is to use full bridge inverter (FBI) to ensure electrical decoupling motor phases [3][4]. Numerous studies have compared different multiphase systems [3]-[6] but either manufacturing or cost aspects are usually omitted. This point is particularly crucial in automotive industry as it relies on a mass production market [7]. This aspect should be considered even at the early stage of the study. This is usually the case when design assumptions are done in order to restrict the scope of the study. However, motor design influences the inverter design and vice versa. That is why this paper proposes a comparison between three pre-selected drives including both motor and inverter. Criteria are proposed in order to consider different aspects and find a tradeoff between performances and estimated manufacturing complexity. Drives are then evaluated based on these criteria and dynamic behaviors are presented, such as torque ripple both in healthy state and after an OPF.

## II. DRIVE DESIGN ASSUMPTIONS AND PRESENTATION OF THE THREE COMPARED DRIVES

### A. Application requirements

An electro-hydraulic power steering (EHPS) actuator consists in an electric motor driving a hydraulic pump, connected to a hydraulic piston (Fig. 1). The motor allows to manage efficiently the level of pressure and flow-rate by controlling its speed and torque. Set point references directly depend on actual vehicle speed, angular position of steering wheel and torque provided by the driver [8]. This aspect is not further detailed, the paper rather focusing on the design of the electric motor and the associated inverter. In case of fault occurrence, the actuator has to keep a given level of torque in order to prevent any sudden loss of assistance. Maximum operating points and integration constraints are given in Table I for a truck application. Only constant torque region is considered for the design. Machine should be able to produce 15Nm at 4500rpm. As the battery voltage is quite low and the application requires a relative important torque, current flowing into the machine will be relatively high in comparison with available transistor current ratings. Another important constraint is the total cost of the solutions, leading to several a priori design assumptions to reduce the scope of this study.

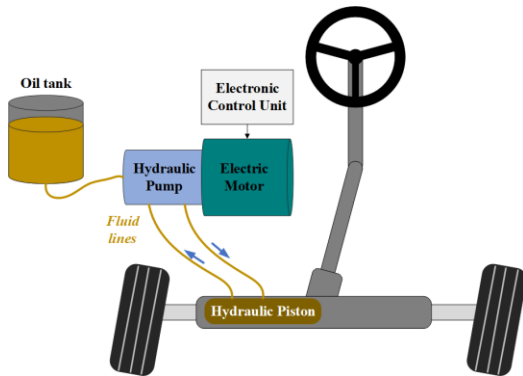

Fig. 2. Simplified schematic of an electro hydraulic power steering

TABLE I. APPLICATIONS REQUIREMENTS

Parameter	Symbol	Value
DC bus voltage	$U_{DC}$	24 V
Maximum motor speed	$\Omega_{max}$	4500 rpm
Maximum motor torque	$T_{max}$	15 Nm
Maximum motor height	$H_{max}$	90 mm
Maximum motor diameter	$D_{max}$	180 mm

### B. Motor design assumptions

Some assumptions have been made prior to the design of machines to account for manufacturing constraints. Radial flux motors are preferred over axial flux ones. Indeed, axial flux machines usually require two-sided rotor or stator to balance the efforts on bearings, then complicating a lot the mechanical integration.

As it is common now for automotive applications, only concentrated tooth winding topologies are considered. Despite some drawbacks mainly due to stator field harmonics, it allows to shorten the length of machine (by reducing the end-winding) while simplifying the winding process. Moreover, compared to distributed windings, each coil is more magnetically and thermally decoupled from the others [9]. This is also an advantage for fault-tolerant designs. Tangential Internal Permanent Magnet (TIPM) rotor is preferred for this study. The simple rectangular shape of the magnets allows to reduce overall manufacturing cost (cheaper material and easier for machine assembly). Fig. 2 gives an overview of machine topology. Another constraint linked to the windings is the number of coils. Too many coils mean a greater number of connections both inside the motor or on the electronics printed circuit board (PCB). That is why a maximum number of coils of fifteen have been chosen. This assumption reduces the number of allowed topologies, leading to only three kinds of considered multiphase machines : five-phase, six-phase and seven-phase ones.

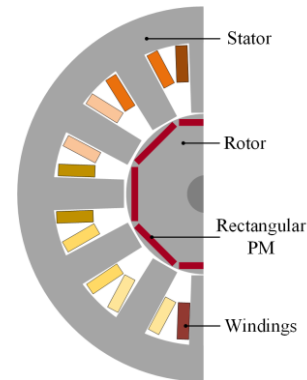

Fig. 1. Tooth-concentrated winding stator with TIPM rotor

### C. Inverter design assumptions

Voltage Source Inverter (VSI) are used as it is a widespread solution for this kind of application. Only two different topologies have been studied: the half-bridge inverter (HBI) and the full-bridge inverter (FBI) configurations, as illustrated in Fig. 3. The half-bridge configuration is quite standard: one extremity of machine phases is connected to an inverter leg, while the other is connected to the neutral point. In full-bridge topology, neutral point does not exist: each extremity of the phase is connected to an inverter leg. This

configuration allows an electrical decoupling between phases, which is an advantage for FT designs. However, this configuration is more complex to control due to the presence of a zero-sequence current which must be regulated. Another apparent drawback is the number of components: a minimum of  $4n$  transistors to drive a  $n$ -phase machine. In low-voltage high current applications, it is mitigated by two facts in the considered application. Firstly, phase currents are relatively high and transistors must be parallelized in HBI configuration to reduce excessive losses. Secondly, phase voltage is limited to the DC bus voltage in FBI topology rather than half this value in HBI. Consequently, coil turns could be doubled and then phase currents are divided by two for a given torque. It means that parallelization of transistors is not always mandatory for FBI. In both HBI and FBI configurations, total number of transistors highly depends on machine characteristics and particularly its maximum phase current. This should be a point of attention while designing the electric drive.

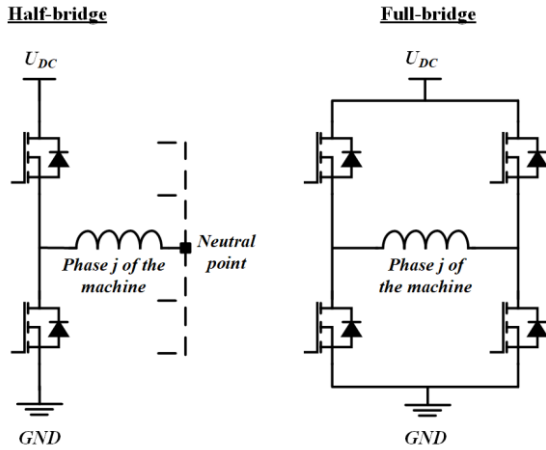

Fig. 3. HBI and FBI topology supplying a motor phase

#### D. Selected drives

A first motor design iteration has been done in order to find the most promising structure for each  $n$ -phase machine. Different tooth/poles combinations as well as winding configurations (single or double layers) have been tested while varying geometric parameters. Finally, three motor configurations have been selected with double-layer winding: 10-tooth/8-poles five-phase machines, 12-tooth/10-poles six-phase machines and 14-tooth/12-poles seven-phase machines. Asymmetrical configuration [10] is preferred for six-phase as it allows to reduce the harmonic rank of torque pulsation: twelfth rather than sixth. It is also interesting to note that tooth/poles configurations are ones which maximize the fundamental component of magnetomotive force, according to [11]. Then a second iteration has been done. It consisted in coupling each machine both with HBI and FBI. Almost 160 drives have been evaluated and only the three best promising are presented in this paper: a five-phase and a six-phase machine driven by a FBI and a seven-phase machine supplied by a HBI. FBI configuration for seven-phase machine are not competitive due to too many required transistors and a more complex control strategy. Main characteristics of machines are expressed in Table II.

TABLE II. CHARACTERISTICS OF SELECTED MACHINES

	Five-phase	Six-phase	Seven-phase
Number of pole pairs $n_{pp}$ [-]	4	5	6
Number of coils $n_{coil}$ [-]	10	12	14
Voltage Constant - 1 <sup>st</sup> harmonic component $k_{emf1}$ [mV/ (rad. s <sup>-1</sup> )]	45.8	41.4	19.4
Voltage Constant - 3 <sup>rd</sup> harmonic component $k_{emf3}$ [mV/ (rad. s <sup>-1</sup> )]	5.6	3.4	0.9
Voltage Constant - 5 <sup>th</sup> harmonic component $k_{emf5}$ [mV/ (rad. s <sup>-1</sup> )]	0.0	3.3	0.3
Phase Resistance R [mΩ]	1.2	1.2	0.3
Inductance in $(\alpha_1-\beta_1)$ plane $L_{\alpha\beta 1}$ [μH]	33.6	43.4	10.4
Inductance in $(\alpha_2-\beta_3)$ $L_{\alpha\beta 2}$ [μH]	23.1	18.4	4.7
Inductance in $(\alpha_3-\beta_3)$ $L_{\alpha\beta 3}$ [μH]	-	-	7.9
Inductance in zero sequence axis $L_z$ [μH]	0.8	31.2	0.1

### III. COMPARISON CRITERIA

The aim of this study is to compare the three selected drives in a systemic approach based on different categories. Two categories are arbitrary defined: motor related criteria and inverter and its control ones. Manufacturing criteria are also considered.

#### A. Motor criteria

A common factor to compare different machines is the motor constant parameter  $k_m$ . As expressed in (1), it is the ratio of the electromagnetic torque produced  $T_{em}$  and the square root of the copper losses  $P_{Cu}$ . It could be seen as the intrinsic capability of the machine to produce torque at lowest copper losses.

$$k_m = \frac{T_{em}}{\sqrt{P_{Cu}}} \quad (1)$$

Another important point is the thermal behavior of the machines. In order to consider this aspect, losses are gathered based on their location, reflecting the potential difficulties to evacuate the heat. Rotor losses  $P_{rot}$  considers both permanent magnet and iron rotor losses while stator losses  $P_{stat}$  gathers the copper and the iron stator losses. These losses are evaluated via Finite Elements Analysis (FEA).

In steering application, it is also important to have a relatively low ripple of torque in order to not introduce parasitic steering feelings to the driver. This parameter will be evaluated both in healthy mode, without any fault occurrences, and after OPFs. Only the healthy variation  $\Delta T_{healthy}$  is stored in motor criteria category. As it will be explained latter, torque ripples after one or two OPF, respectively  $\Delta T_{1OPF}$  and  $\Delta T_{2OPF}$ , are considered with control reconfiguration and then highly depend on it.

At this stage of study, it is quite complicated to precisely estimate the cost of a solution. Previous part assumptions are linked to qualitative criteria but their impact is complex to quantify. On a first approximation, the mass of copper  $M_{Cu}$  and the mass of magnets  $M_{mag}$  can be considered as indicators of motor price.

## B. Inverter and control criteria

Total losses on the power stage  $P_{invTot}$  is the main criterion to evaluate the performances of the inverter. It gathers both diodes (conduction and recovery) and transistors (conduction and switching) losses. These losses are approximated based on analytical formula and by extracting phase current waveforms obtained by simulations. Another point to mention is the total number of transistors  $n_T$ . It influences not only the direct cost of material but also the area taken on the PCB, which could be challenging in integrated actuator (motor and inverter in the same housing).

It is also important to consider the control complexity. Indeed, in automotive applications, control algorithms will be integrated into microcontrollers with a given computing power. Tasks linked to the control have to be solved in a certain amount of time to do not interfere with other tasks, especially the ones dedicated to the safety. The control complexity might also have an influence on software validations process: simpler the code is, cheaper is the validation. To have an idea of such a complexity, the number of closed-loop current controllers  $n_{CLC}$  is chosen as criterion. Control has also an important part on torque ripples reductions after an OPF. Then,  $\Delta T_{1OPF}$  and  $\Delta T_{2OPF}$  are stored in this category. To be noticed that  $\Delta T_{2OPF}$  considers the worst case (as results are different if the two open phases are adjacent or not) for each drive. At last, another criterion is defined, referring as  $k_{OC\_OPF}$ , and represents the ratio between maximum rms phase current after one OPF and rms phase current in healthy condition. It could be seen as the oversizing current ratio to stand 1OPF condition.

## IV. ELECTRIC DRIVES MODEL AND SIMULATION

In order to compare the three selected drives, Generalized Vector Formalism is used, as it is well suited to study multiphase systems. Using generalized Concordia transformation, multiphase system can be studied in different subspaces, associated to a particular set of harmonics [12] [13]. Indeed, if Back Electromotive Force (BEMF) are not purely sinusoidal, current references in secondary or tertiary subspaces could be different from zero and should be controlled. As a consequence, Maximum Torque Per Ampere (MTPA) is used to generate (non-necessary sinusoidal) current references [13] [14].

$$\vec{i}^{ref} = \frac{T_{em}^{ref}}{\|\vec{e}\|^2} \vec{e} \quad (2)$$

where  $\vec{i}^{ref}$  is the reference current vector,  $T_{em}^{ref}$  is the reference electromagnetic torque and  $\vec{e}$  is the speed-normalized BEMF vector  $\vec{e} = \frac{\vec{e}}{\Omega}$ .

After OPF occurs, it is possible to modify (2) to produce a theoretical constant torque. It consists in replacing the vector  $\vec{e}$  by a modified vector  $\vec{e}_{OPF}$  including only the terms associated to the remaining phases. In addition, if machine has a neutral point, it is necessary to compute the zero-sequence term and remove it. The method is detailed in [14].  $\Delta T_{1OPF}$  and  $\Delta T_{2OPF}$  criteria are obtained after such reconfigurations. To be noticed that the same method has been used to design the controllers for each drive.

Some assumptions are made for a sake of simplification. Inductances are considered as constant values independent

from rotor position or phase current. Despite the use of TIPM rotor, saliency effects are not considered in this study and saturation effects are also neglected. In addition, Electromagnetic Interferences (EMI) filter is not simulated. It usually requires an in depth-study for a given actuator, especially if both common and differential mode filters have to be designed. However, alternative criteria such as current total harmonic distortion could be a good indicator of filtering effort. These simplifications will be discussed later along with the results. A simplified model schematic is given in Fig. 4.

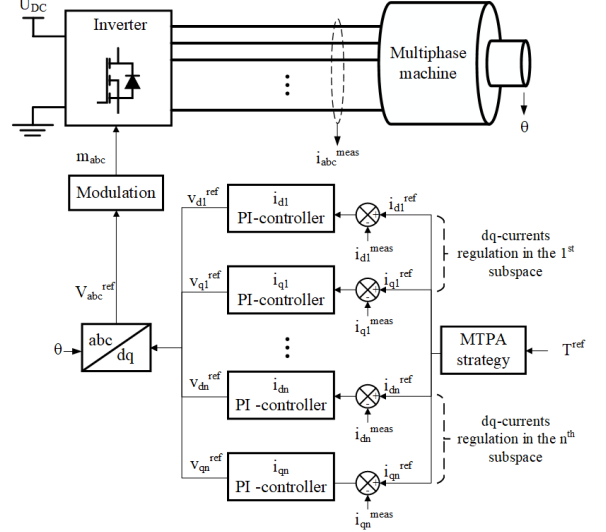

Fig. 4. Simplified model schematic

## V. COMPARISON RESULTS

### A. Overview

Fig. 5 gives the current waveforms for the three proposed drives. It is obtained for a torque reference of 15Nm and a mechanical speed of 4500rpm; corresponding to the maximum operating point. At 5ms, an OPF fault is emulated by deactivating the transistors command of one phase. MTPA reconfiguration control is used.

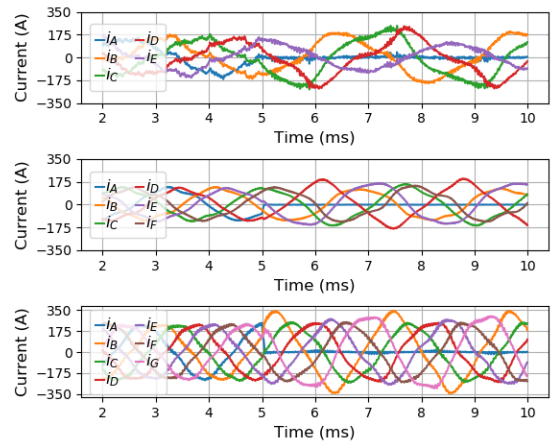

Fig. 5. Phase currents (Top: five-phase drive / middle: six-phase drive / bottom: seven phase drives).

Fig. 6 highlights the main difference between the five and six-phase drives from one side, and the seven-phase one from the other. As discussed earlier, the use of FBI configuration could lead to a reduction of the current at a given torque compared to HBI. Fig. 7 represents the behavior after 1OPF.

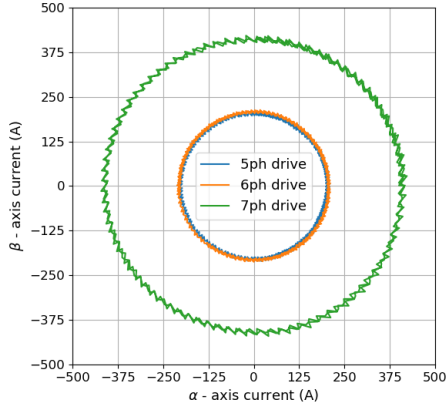

Fig. 6. Phase Current trajectories in  $(\alpha_1-\beta_1)$ -frame in healthy mode

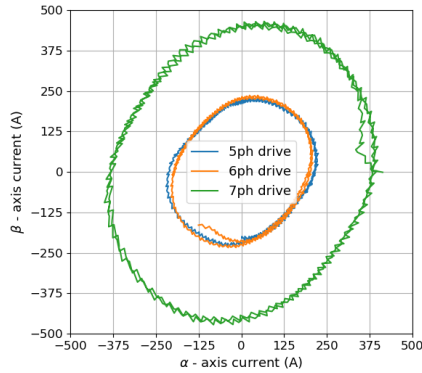

Fig. 7. Phase Current trajectories in  $(\alpha_1-\beta_1)$ -frame after 1OPF

Circular phase current trajectories become ovalized due to the lack of one phase and the magnitudes increase to guarantee a constant mean torque. Both Fig. 6 and Fig. 7, also highlight the impact of the control: small current oscillations exist.

### B. Comparison at maximum operating point 15Nm – 4500rpm

In order to ease the comparison, five-phase drive is chosen as a reference. Each evaluated criterion is normalized by this reference. Results are thus presented in per unit in Table IV for the maximum operating point 15Nm – 4500rpm. Seven-phase drive is highlighted in this table as the less competitive solution regarding inverter criteria, despite low torque ripple after OPF. With only seven legs, the seven-phase VSI has more losses than the five or six-phase solution (respectively ten and twelve legs). Indeed, FBI allows to multiply by two the maximum voltage applied to phase and consequently to reduce the required current. This kind of inverter configuration seems to be more suitable for the

studied low-voltage application, but zero-sequence current should be considered as discussed latter. Seven-phase motor has also higher stator losses, mainly due to a high polarity that increases the electrical frequency and then iron losses.

Motor losses for the six-phase drive are a little bit more important than the five-phase ones but the magnet mass is lower. This point could be a significant advantage knowing the price of rare-earth material. Moreover, six-phase drive has better results after 2OPF than five-phase one in terms of torque ripple at the given operating point. Otherwise, both drives are quite comparable. However, there is a noticeable difference between the evaluated five-phase and six-phase drives. Zero sequence currents have to be managed and respective impedance among the zero-sequence axis are quite different as shown in Table III. Both drives use double pulse width modulation [15], but due to a relatively low impedance, the current magnitude is high in the case of the five-phase drive. This current will have an impact on the design of the input DC filter. This is a particular point of interest that is not presented in this study but have to be mentioned.

TABLE III. COMPARISON OF ZERO SEQUENCE AXIS IMPEDANCE AND CURRENT

	$Z_z$ @4500rpm [mΩ]	$I_{z,max}$ @4500rpm [A]	$Z_z$ @1000rpm [mΩ]	$I_{z,max}$ @1000rpm [A]
5ph	1.52	129	0.34	110
6ph	75.50	20.7	16.34	36.1
7ph	0.28	-	0.06	-

### C. Influences of the control

Table V gives the torque ripple  $\Delta T$ , the maximum rms phase current  $I_{rms,max}$  and the copper losses  $P_{Cu}$ , for different fault configurations for each drives. “ap” suffix after 2OPF refers to adjacent phases, while “nap” refers to non-adjacent phases. The three criteria are given in case of control reconfiguration among MTPA technology. After 2OPF, keeping the same average torque implies big constraints both on the motor and on the inverter. If torque reference is not lowered, oversizing should be performed to withstand these constraints. Moreover, torque ripple remains relatively high after fault occurrences. Indeed, after an OPF, MTPA strategy induces non-constant references and the PI controllers are not suited for this kind of operations. At a relatively high electrical frequency, these limitations are highlighted. Solutions have been explored in the literature [16] [17] to propose other kind of controllers. However, care should be taken while implementing it in a real time microcontroller to keep computational time as low as possible.

TABLE IV. COMPARISON BETWEEN FIVE, SIX AND SEVEN-PHASE DRIVES AMONG DEFINED CRITERIA, AT 15Nm-4500RPM OPERATING POINT

Criteria evaluated at 15Nm - 4500rpm	Motor criteria						Inverter and control criteria					
	$k_m$	$P_{stat}$	$P_{rot}$	$\Delta T_{healthy}$	$M_{mag}$	$M_{Cu}$	$P_{invTot}$	$n_{tr}$	$n_{CLC}$	$\Delta T_{1OPF}$	$\Delta T_{2OPF}$	$k_{OC\_OPF}$
5ph drive ( $f_s = 300Hz$ )	1.00	1.00	1.00	1.00	1.00	1.00	1.00	1.00	1.00	1.00	1.00	1.00
6ph drive ( $f_s = 375 Hz$ )	1.00	1.17	1.10	0.92	0.80	1.05	1.04	1.20	1.20	0.96	0.54	0.89
7ph drive ( $f_s = 450Hz$ )	1.06	1.35	0.89	0.92	0.89	1.03	2.13	1.40	1.20	0.80	0.77	0.90

TABLE V. DRIVE COMPARISON AMONG DIFFERENT FAULT CONFIGURATIONS, AT 15NM – 4500RPM OPERATING POINT

		Healthy	1OPF	2OPF-ap	2OPF-nap
5ph ( $f_e = 300\text{Hz}$ )	$\Delta T$	1.00	4.71	4.42	9.64
	$I_{\text{rms,max}}$	1.00	1.52	1.84	2.31
	$P_{\text{Cu}}$	1.00	1.36	1.74	2.30
6ph ( $f_e = 375\text{Hz}$ )	$\Delta T$	0.92	4.49	5.00	5.21
	$I_{\text{rms,max}}$	0.90	1.24	1.57	1.58
	$P_{\text{Cu}}$	1.00	1.25	1.57	1.57
7ph ( $f_e = 450\text{Hz}$ )	$\Delta T$	0.91	3.76	7.36	1.85
	$I_{\text{rms,max}}$	1.65	2.28	3.23	3.04
	$P_{\text{Cu}}$	0.89	1.09	1.58	1.36

## VI. DISCUSSIONS AND CONCLUSIONS

Several multiphase drives have been designed for an EHPS application and the three best promising solutions have been compared. This study highlighted the impact of the inverter configuration on the overall performances of the drive, for the studied low-voltage application. Seven-phase one showed good results regarding torque oscillations but the higher current rating leads to too much losses both for the machine and the inverter. Both five-phase and six-phase solutions are then more competitive. Five-phase one has the advantage to require less components: coils, phase connections and transistors. On the contrary, six-phase drive includes a 12-tooth/10-poles machines that is a widespread structure for three-phase motors. Moreover, six-phase drives could be approximated to twice a three-phase one. This is an advantage for electronic components availability: integrated chips such as gate drivers already exist and are thought to drive three-phase motors. Both five-phase and six-phase are promising and an in-depth study should be performed to precise the evaluated cost of each solution.

Particular points are out of the scope of this paper and should be studied with care. For instance, saliency and saturation could impact the performances of the drives, especially regarding control limitation. This could balance the different results. Electromagnetic compatibility should also be looked at in details: H-type topology allows zero sequence components circulations and then could lead to hard constraints on the design of common and differential mode filters. To this aspect, the six-phase drive should be better than the five-phase one due to higher zero sequence impedance.

Future trends with highest level of safety regarding ISO26262 could lead to the use of double input lane supply in order to prevent total loss of power in case of battery connector disconnection. In this way, double star configurations (both for five and six-phase machines) should be a solution to study. It requires the same number of transistors than FBI without the problematic of zero-sequence, but care should be taken looking at magnetic coupling between stars.

At last, transistor reference choice is a discrete variable and then, depending on the allowed overrating, it could change the number of transistors to put in parallel and then modified a lot the solutions. For example, in a 400V high-voltage application or with another transistor choice, the pre-study

prior to the paper could lead to three different solutions than the proposed ones.

## REFERENCES

- [1] E. Levi, "Multiphase Electric Machines for Variable-Speed Applications," *IEEE Trans. Ind. Electron.*, vol. 55, no. 5, pp. 1893–1909, May 2008
- [2] M. Hasoun, A. El afa, and M. Khafallah, "Field Oriented Control of Dual Three-Phase PMSM Based Vector Space Decomposition for Electric Ship Propulsion," in *2019 International Conference of Computer Science and Renewable Energies (ICCSRE)*, Agadir, Morocco, Jul. 2019, pp. 1–6
- [3] L. Zhang, Y. Fan, R. D. Lorenz, A. Nied, and M. Cheng, "Design and Comparison of Three-Phase and Five-Phase FTFCW-IPM Motor Open-End Winding Drive Systems for Electric Vehicles Applications," *IEEE Trans. Veh. Technol.*, vol. 67, no. 1, pp. 385–396, Jan. 2018
- [4] A. Rosen, M. Groninger, and A. Mertens, "Modeling and optimized control of fault-tolerant H-bridge fed multiphase drives," in *2015 17th European Conference on Power Electronics and Applications (EPE'15 ECCE-Europe)*, Geneva, Sep. 2015, pp. 1–6.
- [5] E. Fomasiero, N. Bianchi, and S. Bolognani, "Slot Harmonic Impact on Rotor Losses in Fractional-Slot Permanent-Magnet Machines" *IEEE Trans. Ind. Electron.*, vol. 59, n° 6, p. 2557-2564, June 2012
- [6] A. Negahdari, A. G. Yepes, J. Doval-Gandoy, and H. A. Toliyat, "Efficiency Enhancement of Multiphase Electric Drives at Light-Load Operation Considering Both Converter and Stator Copper Losses," *IEEE Trans. Power Electron.*, vol. 34, no. 2, pp. 1518–1525, Feb. 2019
- [7] E. Carraro, N. Bianchi, S. Zhang, and M. Koch, "Design and Performance Comparison of Fractional Slot Concentrated Winding Spoke Type Synchronous Motors With Different Slot-Pole Combinations," *IEEE Trans. on Ind. Applicat.*, vol. 54, no. 3, pp. 2276–2284, May 2018
- [8] S. A. Arogeti, D. Wang, C. B. Low, and M. Yu, "Fault Detection Isolation and Estimation in a Vehicle Steering System," *IEEE Trans. Ind. Electron.*, vol. 59, no. 12, pp. 4810–4820, Dec. 2012
- [9] F. Becker and F. Scuiller, "Fault-tolerant control of a 7-Phase Surface-mounted PM Machine with tooth-concentrated winding," in *2020 IEEE International Conference on Industrial Technology (ICIT)*, Buenos Aires, Argentina, Feb. 2020, pp. 1044–1049.
- [10] Y. Luo and C. Liu, "Pre- and Post-Fault Tolerant Operation of a Six-Phase PMSM Motor Using FCS-MPC Without Controller Reconfiguration," *IEEE Trans. Veh. Technol.*, vol. 68, no. 1, pp. 254–263, Jan. 2019
- [11] B. Aslan, E. Semail, J. Korecki, and J. Legraner, "Slot/pole combinations choice for concentrated multiphase machines dedicated to mild-hybrid applications," in *IECON 2011 - 37th Annual Conference of the IEEE Industrial Electronics Society*, Melbourne, Vic, Australia, Nov. 2011, pp. 3698–3703
- [12] X. Kestelyn and E. Semail, "A Vectorial Approach for Generation of Optimal Current References for Multiphase Permanent-Magnet Synchronous Machines in Real Time," *IEEE Trans. Ind. Electron.*, vol. 58, no. 11, pp. 5057–5065, Nov. 2011
- [13] M. Slunjski, O. Stiscia, M. Jones and E. Levi, "General Torque Enhancement Approach for a Nine-Phase Surface PMSM With Built-In Fault Tolerance". *IEEE Trans. Ind. Electron.* 2021, 68, 6412–6423.
- [14] X. Kestelyn and E. Semail, "A Vectorial Approach for Generation of Optimal Current References for Multiphase Permanent-Magnet Synchronous Machines in Real Time", *IEEE Transactions on Industrial Electronics*, vol. 58, no. 11, pp. 5057-5065, 2011.
- [15] A. E. Aroudi, M. S. Al-Numay, W. G. Lu, J. M. Bosque-Moncusí, and H. H.-C. Iu, "A Combined Analytical-Numerical Methodology for Predicting Subharmonic Oscillation in H-Bridge Inverters Under Double Edge Modulation", *IEEE Trans. Circuits Syst. I*, vol. 65, no. 7, pp. 2341–2351, Jul. 2018
- [16] H. Guzman et al., "Comparative Study of Predictive and Resonant Controllers in Fault-Tolerant Five-Phase Induction Motor Drives," *IEEE Trans. Ind. Electron.*, vol. 63, no. 1, pp. 606–617, Jan. 2016
- [17] D. T. Vu, N. Ky Nguyen, and E. Semail, "Eliminations of Low-frequency Current Harmonics for Five-phase Open-end Winding Non-sinusoidal Machine Drives applying Neural Networks," in *IECON 2020 The 46th Annual Conference of the IEEE Industrial Electronics Society*, Singapore, Singapore, Oct. 2020, pp. 4839–4844.