



Science Arts & Métiers (SAM)

is an open access repository that collects the work of Arts et Métiers Institute of Technology researchers and makes it freely available over the web where possible.

This is an author-deposited version published in: <https://sam.ensam.eu>
Handle ID: [.http://hdl.handle.net/10985/22596](http://hdl.handle.net/10985/22596)

To cite this version :

Eric SEMAIL, Jean-Paul HAUTIER, Xavier KESTELYN - Multiphase system supplied by PWM VSI. A new technic to compute the duty cycles - In: EPE 2003, France, 2003-09 - Multiphase system supplied by PWM VSI. A new technic to compute the duty cycles - 2003

Any correspondence concerning this service should be sent to the repository

Administrator : scienceouverte@ensam.eu



Multi-phase System Supplied by PWM VSI. A New Technic to Compute Duty Cycles.

Xavier Kestelyn, Eric Semail, J.P Hautier.

L2EP, Laboratoire d'Electrotechnique et d' Electronique de Puissance de Lille

ENSAM Lille 8 bd Louis XIV F-59046 LILLE, France

e-mail: eric.semail@lille.ensam.fr

<http://www.univ-lille1.fr/l2ep/>

30th October 2003

Keywords: Multi-phase, VSI, Vectorial PWM, SVM, Multi-machine.

Abstract

When multi-phase machines with magnetic couplings between phases are supplied by triangle intersection PWM, there are parasitic currents. To solve the problem, it is necessary to use Space Vector Modulation. A SVM extended to systems with arbitrary number of phases is proposed. Optimization of time computation and consideration of switching constraints have been considered. Experimental results are given for a vectorial control of a 5-phase machine.

1 Introduction

When multi-phase machines are supplied by VSI controlled by classical triangle intersection PWM, large parasitic currents appeared [2], [8]. This phenomenon is observed even in the steady state with sinusoidal references. In fact, it can be shown that a multi-phase machine is equivalent with a set of fictitious one-phase or two-phase machines which are magnetically independent but mechanically and electrically coupled [1], [13]. The time constants of the different machines are usually quite at all different. The first-harmonic d-q equivalent machine, which produces the torque for the most part, has the greatest time constant. If the switching frequency is chosen with regard to this machine, large parasitic currents are induced in the other machines whose time constants are smaller. To achieve good control with reasonable switching frequency it is important to choose right instantaneous voltages which reduce the parasitic currents. It is not possible with classical triangle intersection PWM but can be handle with pure numerical method [14] or with a Space Vector Modulation extended to multi-phase systems. In particular cases, such SVM controls have already been implemented: [2] and [15] have chosen instantaneous vectors to control dual three-phase induction machines, [4] and [6] to control 5-phase machines. Nevertheless, the proposed technics need to determine the location of the desired reference in a defined sector. This determination increases the computation time, which can become prohibitive to systems with many phases. Moreover switching constraints, as the reduction of the number of switchings in a PWM period, are not always taken into account [2], [4].

A new algorithm is proposed to calculate the duty cycles of each VSI leg with an optimization of time computation and consideration of switching constraints. This new algorithm is based on

a vectorial approach of inverters developed in [3],[7],[5]. This algorithm permits to calculate the duty cycles of each leg with no need of find the location of the reference vector. Moreover the number of switchings in a period of PWM is taken into account.

Even if it is impossible to supply each fictitious system independently, it is possible to impose the right average voltage to each one. In this paper the duty cycles of VSI legs are computed from the references of fictitious systems. To be able to illustrate this technic, we will apply it at a first to a three-phase system with geometrical representations. Then currents of a 5-phase experimental machine are controlled with the proposed SVM.

2 Multi-phase system supplied by PWM VSI

2.1 Presentation of the two used topologies

Usually, to reduce the number of switches, multi-phase systems are star connected and it is impossible to generate zero-sequence current. So, there is loss of one freedom degree. To have more reliability and maximum freedom degrees, the n phases of the system are not electrically coupled. The figures 1 and 2 shows the two topologies of supply.

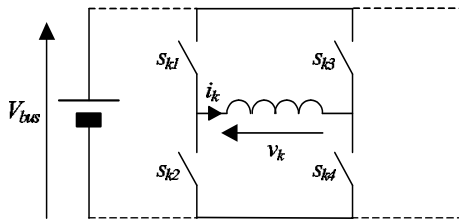

Figure 1: No couplings topology, 2n legs.

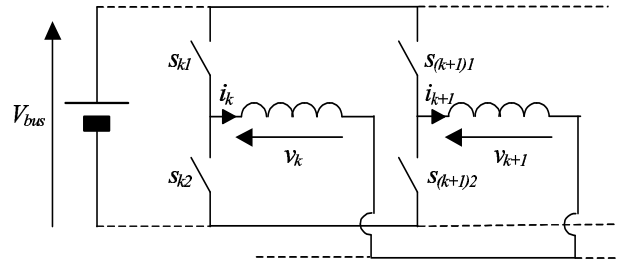

Figure 2: Star Connection topology, n legs.

2.2 Vectorial modelling

In an orthonormal base B_n composed of the vectors $\{\vec{x}_1^n, \vec{x}_2^n, \dots, \vec{x}_n^n\}$ the voltage vector can be defined:

$$\vec{v} = v_1 \vec{x}_1^n + v_2 \vec{x}_2^n + \dots + v_n \vec{x}_n^n$$

where v_k is the voltage across the phase number k .

If the VSI is a two-level one, it can be generated 2^n different voltage vectors.

In a great majority of cases, there are magnetic couplings between the phases of a multi-phase system. The inductance matrix is then:

$$[L_s^n] = \begin{pmatrix} L_{11} & L_{12} & \dots & L_{1n} \\ L_{21} & L_{22} & \dots & L_{2n} \\ \vdots & \vdots & \ddots & \vdots \\ L_{n1} & L_{n2} & \dots & L_{nn} \end{pmatrix}$$

where L_{kk} is the self-inductance of the phase k and L_{jk} is the mutual inductance between the phases j and k .

The magnetic couplings between the phases make difficult the control development and it is better to model the machine in a base where there are no magnetic couplings.

The new matrix inductance $[L_s^d]$, in a base $B_d = \{\vec{x}_1^d, \vec{x}_2^d, \dots, \vec{x}_n^d\}$ where there are no magnetic couplings, is :

$$[L_s^d] = \begin{pmatrix} \Lambda_1 & 0 & \dots & 0 \\ 0 & \Lambda_2 & \dots & 0 \\ \vdots & \vdots & \ddots & \vdots \\ 0 & 0 & \dots & \Lambda_n \end{pmatrix}$$

The linear relations between, Λ and L , \vec{x}^d and \vec{x}^n , are obtained by using an extended Concordia transformation.

In the base B_d , we can define a set of fictitious magnetically independent systems associated to characteristic subspaces of $[L_s^d]$. This approach has been developed for a 5-phase machine [1] supplied by VSI. The 5-phase system can be considered as the association of 3 elementary fictitious machines (figure 3) supplied by 3 fictitious VSI. The Multi-machine Multi-converter System concept [16] can be extended to systems with an arbitrary number of phases.

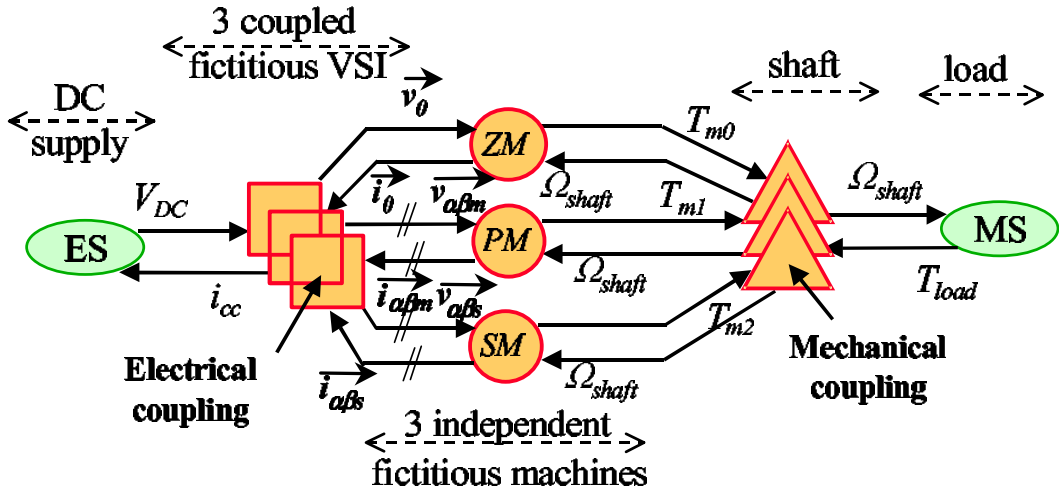

Figure 3: Equivalence between a 5-phase machine and 3 fictitious machines supplied by 3 fictitious VSI.

In figure 3, the 3 fictitious VSI generate 3 new voltage vectors v_0 , v_{dq1} and v_{dq2} . These vectors are obtained by vectorial projections of $[v_1 v_2 v_3 v_4 v_5]$ onto the 3 subspaces associated to the vectors of the base B^d . If instantaneous mode control of voltages is considered, there is a coupling between the 3 VSI. In an average mode control, the 3 VSI are independent. It is this last mode that is considered in this paper.

To determine the duration of the n switching state vectors The voltage reference are then reference of average voltages. Instead of generating the references relative to $[v_1 v_2 v_3 v_4 v_5]$, it is To find them, it is sufficient to apply the same transformation to the initial voltage vector $[v_1 v_2 v_3 v_4 v_5]$. If an average control of voltages is used, the Instead of generating the reference relative to $[v_1 v_2 v_3 v_4 v_5]$, we prefer to generate the average voltage vector reference of each fictitious system. These voltage references are obtained by vectorial projections onto subspaces associated to the vectors of the base B^d .

2.3 Generation of an average voltage vector with consideration of switching constraints

To reduce the number of switchings in a period of PWM, the following switching constraints are imposed:

- A minimum number of switchings are used to generate any initial average voltage reference,
- Only one switching is possible at the same time.

A simple way to respect these two switching constraints is to make the same choice as a triangle intersection PWM:

- Only $n+1$ different voltage vectors are used to generate any initial average voltage reference (A sufficient condition to generate any voltage reference),
- Two voltage vectors consecutively generated by the VSI have only one different coordinate (there is then only one switching between two consecutive voltage vectors),
- Each sequence of generated vectors begins and finishes with the same vector. A simple manner to do that is to repeat the sequence in the reverse order after its generation (there is then no switching between two periods of PWM).

The generated patterns are the same as a triangle intersection PWM but each conduction time of the vectors is computed with an extended SVM. Compared to classical technics [11], [10], [9], [12], it is not necessary to find the sector where the desired vector is. At the beginning of each period of PWM, each duty cycle ($2\alpha_k^n T$) is computed and held during all the period. Figure 4 shows the implemented PWM pattern.

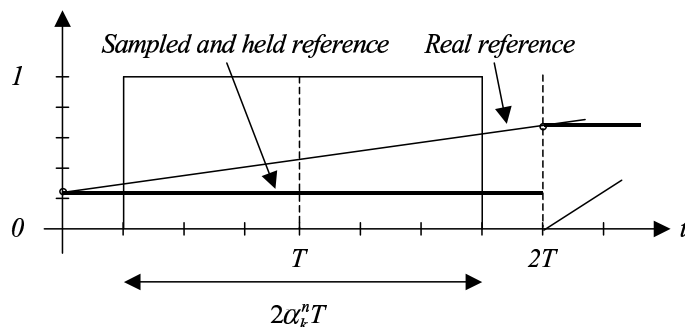

Figure 4: Implemented PWM pattern

3 Case of a three-phase system

3.1 Introduction

For example, let us choose a three-phase machine which 3 phases are coupled. The choice of this system allows to establish the link between the proposed SVM and the classical SVM used to control 3-phase star-coupled machines. In an orthonormal base B_n composed of the vectors $\{\vec{x}_1, \vec{x}_2, \vec{x}_3\}$ the vectorial voltage equation of the machine is:

$$\vec{v}_s = R_s \vec{i}_s + \left[\frac{d\vec{\phi}_s}{dt} \right]_{/B^n}$$

where \vec{v}_s , \vec{i}_s and $\vec{\phi}_s$ are respectively the stator voltage, stator current and stator flux vectors.

Classically, the control of the machine is achieved in a Concordia frame. In other words, the control is carrying out in the base $B^d = \{\vec{x}_z, \vec{x}_a, \vec{x}_b\}$, where there are no magnetic couplings, rather than in the natural base B^n .

We remind the Concordia's transformation C_{33}^{-1} :

$$\begin{pmatrix} \vec{x}_z \\ \vec{x}_a \\ \vec{x}_b \end{pmatrix} = \begin{pmatrix} \frac{1}{\sqrt{3}} & \frac{1}{\sqrt{3}} & \frac{1}{\sqrt{3}} \\ \sqrt{\frac{2}{3}} & -\frac{1}{\sqrt{6}} & -\frac{1}{\sqrt{6}} \\ 0 & +\frac{1}{\sqrt{2}} & -\frac{1}{\sqrt{2}} \end{pmatrix} \begin{pmatrix} \vec{x}_1 \\ \vec{x}_2 \\ \vec{x}_3 \end{pmatrix}$$

3.2 Modelling of the VSI

Due to the two-level control ($v_k = \pm V_{bus}$), the voltage vector $\vec{v} = v_1\vec{x}_1 + v_2\vec{x}_2 + v_3\vec{x}_3$ can take $2^3 = 8$ different values. Figure 5 shows the representation of the different values of \vec{v} (blue crosses) in an orthonormal frame $\{O, \vec{x}_1, \vec{x}_2, \vec{x}_3\}$. Two values separated by only one switching are linked by a line. In this case, we obtain a cube.

To easily spot the different values of the vector \vec{v} , each value is associated to a number between 0 and 7. This number is directly associated to the switching mode. When each decimal number is converted to a three-digit binary number, the 1's in this number indicates that the corresponding phase is supplied by $+V_{bus}$ and the 0's indicates that it is supplied by $-V_{bus}$. The most significant bit (first bit on the left) represents the switching state of phase 1 and so on.

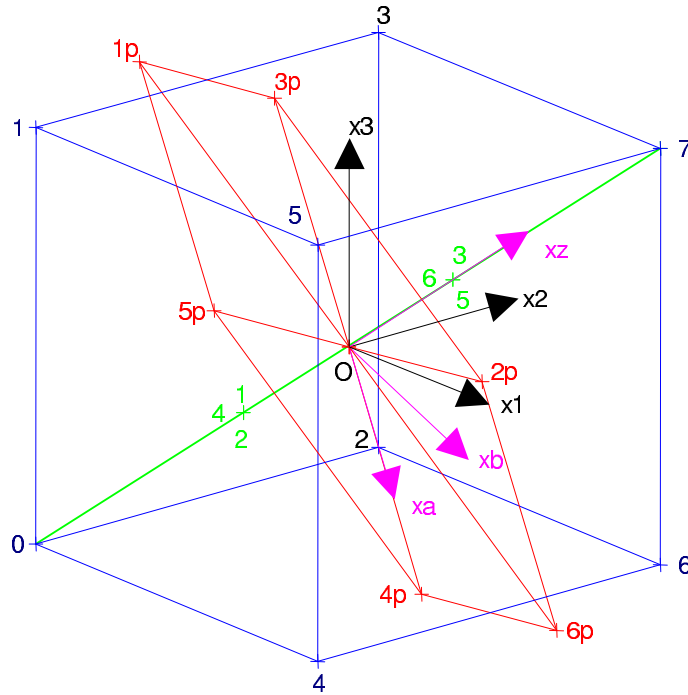

Figure 5: 3D representation of the voltage vector and its projections onto particular subspaces

In the base B^d , the stator inductance matrix only has two different eigen values. One associated to the vector \vec{x}_z , whose value is closed to leakage inductance value, and the other associated to the vectors \vec{x}_a and \vec{x}_b , called cyclic inductance.

Then in the new base B^d it can be defined two particular orthogonal subspaces : a line supported by the vector \vec{x}_z and a plane supported by the vectors \vec{x}_a and \vec{x}_b .

Figure 5 shows the line (in green) and the plane (in red) and the projections of the 2^3 values of the voltage vector onto.

It is important to notice that usually, machines are star connected and then only the plane has to be considered. In usual SVM, this plane is considered as a complex plane and the VSI is characterized by the hexagon that can be seen on Figure 5.

3.3 Generation of an average voltage in a period of PWM

The generation of the initial average voltage reference is now become generations of two references $\overrightarrow{\langle v_{z_{ref}} \rangle}$ and $\overrightarrow{\langle v_{m_{ref}} \rangle}$, projections of $\overrightarrow{\langle v_{ref} \rangle}$ respectively belonging to the line and the plane, such as :

$$\overrightarrow{\langle v_{ref} \rangle} = \overrightarrow{\langle v_{z_{ref}} \rangle} + \overrightarrow{\langle v_{m_{ref}} \rangle}$$

There are many solutions to respect the switching constraints previously defined but a natural choice consists in using the family (0,7) composed by four vectors as a triangle intersection PWM does. In this family there are $3! = 6$ different combinations which respect the constraints (forming six identical tetrahedrons in the cube which are projected in six triangles onto the plane).

The classical technic needs to find the location of the vector into the 6 tetrahedrons (or the six triangles if there is a star coupling) and then to calculate the conduction time of the four vectors composing the chosen volume (or sector).

Due to the symmetry of the six tetrahedrons (or triangles), it is no more necessary to find this location. Indeed, due to the two levels command, voltage vectors are opposite by two ($\vec{v}_k = -\vec{v}_{(2^n-1)-k}$) and a vector associated to a negative duty cycle is the same as its opposite associated to a positive duty cycle.

If we take for example the combination of the vectors (0 1 3 7), the vector $\overrightarrow{\langle v_{ref} \rangle}$ (wherever it is located into the cube) is given by the relation :

$$\overrightarrow{\langle v_{ref} \rangle} = \alpha_0^d \vec{v}_0 + \alpha_1^d \vec{v}_1 + \alpha_3^d \vec{v}_3 + \alpha_7^d \vec{v}_7 \quad (1)$$

Where the $\alpha_k^d \in [-1, 1]$ can be positive or negative.

The aim is to write the vector $\overrightarrow{\langle v_{ref} \rangle}$ in a manner :

$$\overrightarrow{\langle v_{ref} \rangle} = V_{bus}((2\alpha_1^n - 1)\vec{x}_1 + (2\alpha_2^n - 1)\vec{x}_2 + (2\alpha_3^n - 1)\vec{x}_3) \quad (2)$$

where $\alpha_k^n \in [0, 1]$ are the duty cycles of the VSI legs.

If we give the vectors \vec{v}_0 , \vec{v}_1 , \vec{v}_3 and \vec{v}_7 as an expression of V_{bus} , \vec{x}_1 , \vec{x}_2 and \vec{x}_3 we obtain :

$$\begin{aligned} \vec{v}_0 &= -V_{bus}\vec{x}_1 - V_{bus}\vec{x}_2 - V_{bus}\vec{x}_3 & \vec{v}_1 &= -V_{bus}\vec{x}_1 - V_{bus}\vec{x}_2 + V_{bus}\vec{x}_3 \\ \vec{v}_3 &= -V_{bus}\vec{x}_1 + V_{bus}\vec{x}_2 + V_{bus}\vec{x}_3 & \vec{v}_7 &= +V_{bus}\vec{x}_1 + V_{bus}\vec{x}_2 + V_{bus}\vec{x}_3 \end{aligned}$$

These four equations placed in equation (1) gives:

$$\overrightarrow{\langle v_{ref} \rangle} = V_{bus}((- \alpha_0^d - \alpha_1^d - \alpha_3^d + \alpha_7^d)\vec{x}_1 + (- \alpha_0^d - \alpha_1^d + \alpha_3^d + \alpha_7^d)\vec{x}_2 + (- \alpha_0^d + \alpha_1^d + \alpha_3^d + \alpha_7^d)\vec{x}_3) \quad (3)$$

As the four vectors \vec{v}_0 , \vec{v}_1 , \vec{v}_3 and \vec{v}_7 are used in a period of PWM, we have the relation:

$$\alpha_0^d + \alpha_1^d + \alpha_3^d + \alpha_7^d = 1 \quad (4)$$

With the use of relation (4) in equation (3) we obtain :

$$\overrightarrow{\langle v_{ref} \rangle} = V_{bus}((2\alpha_1^d - 1)\vec{x}_1 + (2(\alpha_3^d + \alpha_7^d) - 1)\vec{x}_2 + (2(\alpha_1^d + \alpha_3^d + \alpha_7^d) - 1)\vec{x}_3) \quad (5)$$

By identification of the equations (2) and (5) we can finally find:

$$\begin{aligned}\alpha_1^n &= \alpha_7^d \\ \alpha_2^n &= \alpha_3^d + \alpha_7^d \\ \alpha_3^n &= \alpha_1^d + \alpha_3^d + \alpha_7^d\end{aligned}$$

3.4 Computation of the α_k^d 's

To calculate an α_k^d it is sufficient to achieve successive cross products between the vectors of the family. Indeed the cross product of a vector by itself is null: $\vec{g} \wedge \vec{g} = \vec{0}$. To use this technic of calculation, it is impossible to have two co-linear vectors. The easier solution to respect this constraint is to add a fourth dimension to each vector.

As an example, let calculate α_7^d :

$$\begin{aligned}\overrightarrow{\langle v_{ref} \rangle} \wedge \vec{v}_0 &= (\alpha_0^d \vec{v}_0 + \alpha_1^d \vec{v}_1 + \alpha_3^d \vec{v}_3 + \alpha_7^d \vec{v}_7) \wedge \vec{v}_0 = \alpha_1^d \vec{v}_1 \wedge \vec{v}_0 + \alpha_3^d \vec{v}_3 \wedge \vec{v}_0 + \alpha_7^d \vec{v}_7 \wedge \vec{v}_0 \\ \overrightarrow{\langle v_{ref} \rangle} \wedge \vec{v}_0 \wedge \vec{v}_1 &= \alpha_3^d \vec{v}_3 \wedge \vec{v}_0 \wedge \vec{v}_1 + \alpha_7^d \vec{v}_7 \wedge \vec{v}_0 \wedge \vec{v}_1 \\ \overrightarrow{\langle v_{ref} \rangle} \wedge \vec{v}_0 \wedge \vec{v}_1 \wedge \vec{v}_3 &= \alpha_7^d \vec{v}_7 \wedge \vec{v}_0 \wedge \vec{v}_1 \wedge \vec{v}_3 \\ \alpha_7^d &= \frac{\overrightarrow{\langle v_{ref} \rangle} \wedge \vec{v}_0 \wedge \vec{v}_1 \wedge \vec{v}_3}{\vec{v}_7 \wedge \vec{v}_0 \wedge \vec{v}_1 \wedge \vec{v}_3}\end{aligned}$$

After rearrangement it appears the mixed product:

$$\alpha_7^d = \frac{(\vec{v}_0 | \vec{v}_1 | \vec{v}_3 | \overrightarrow{\langle v_{ref} \rangle})}{(\vec{v}_0 | \vec{v}_1 | \vec{v}_3 | \vec{v}_7)}$$

By the same way, it is possible to calculate the others α_k^d 's:

$$\alpha_3^d = \frac{(\vec{v}_0 | \vec{v}_1 | \overrightarrow{\langle v_{ref} \rangle} | \vec{v}_7)}{(\vec{v}_0 | \vec{v}_1 | \vec{v}_3 | \vec{v}_7)} \quad \alpha_1^d = \frac{(\vec{v}_0 | \overrightarrow{\langle v_{ref} \rangle} | \vec{v}_3 | \vec{v}_7)}{(\vec{v}_0 | \vec{v}_1 | \vec{v}_3 | \vec{v}_7)} \quad \alpha_0^d = \frac{(\overrightarrow{\langle v_{ref} \rangle} | \vec{v}_1 | \vec{v}_3 | \vec{v}_7)}{(\vec{v}_0 | \vec{v}_1 | \vec{v}_3 | \vec{v}_7)}$$

The calculation of a mixed product is the same as a determinant and requires only a few sums and products. The denominator is constant and can be calculated off-line. The numerator has only one variable, $\overrightarrow{\langle v_{ref} \rangle}$, and can be reduced to few calculations.

4 Case of a 5-phase system

4.1 Introduction

To reduce the number of legs, we choose to star connect the phases of the machine. The base B^d where there are no magnetic couplings is deduced with the extended Concordia's transformation below:

$$\begin{pmatrix} \vec{x}_z \\ \vec{x}_a \\ \vec{x}_b \\ \vec{x}_c \\ \vec{x}_d \end{pmatrix} = \begin{pmatrix} \frac{1}{\sqrt{5}} & \frac{1}{\sqrt{5}} & \frac{1}{\sqrt{5}} & \frac{1}{\sqrt{5}} & \frac{1}{\sqrt{5}} \\ \sqrt{\frac{2}{5}} & \sqrt{\frac{2}{5}} \cos \frac{2\pi}{5} & \sqrt{\frac{2}{5}} \cos \frac{4\pi}{5} & \sqrt{\frac{2}{5}} \cos \frac{6\pi}{5} & \sqrt{\frac{2}{5}} \cos \frac{8\pi}{5} \\ 0 & \sqrt{\frac{2}{5}} \sin \frac{2\pi}{5} & \sqrt{\frac{2}{5}} \sin \frac{4\pi}{5} & \sqrt{\frac{2}{5}} \sin \frac{6\pi}{5} & \sqrt{\frac{2}{5}} \sin \frac{8\pi}{5} \\ \sqrt{\frac{2}{5}} & \sqrt{\frac{2}{5}} \cos \frac{4\pi}{5} & \sqrt{\frac{2}{5}} \cos \frac{8\pi}{5} & \sqrt{\frac{2}{5}} \cos \frac{12\pi}{5} & \sqrt{\frac{2}{5}} \cos \frac{16\pi}{5} \\ 0 & \sqrt{\frac{2}{5}} \sin \frac{4\pi}{5} & \sqrt{\frac{2}{5}} \sin \frac{8\pi}{5} & \sqrt{\frac{2}{5}} \sin \frac{12\pi}{5} & \sqrt{\frac{2}{5}} \sin \frac{16\pi}{5} \end{pmatrix} \begin{pmatrix} \vec{x}_1 \\ \vec{x}_2 \\ \vec{x}_3 \\ \vec{x}_4 \\ \vec{x}_5 \end{pmatrix}$$

Due to the 5 dimensions, it is no more possible to represent graphically the different values of the voltage vectors in the natural base. Three orthogonal subspaces can be defined:

- a line associated to the vector \vec{x}_z
- a plane called main associated to the vectors \vec{x}_a and \vec{x}_b
- a plane called secondary associated to the vectors \vec{x}_c and \vec{x}_d

The 2^5 projections of the values of the voltage vector onto these subspaces are shown in figures 6 and 7. The line is not considered due to the star connection.

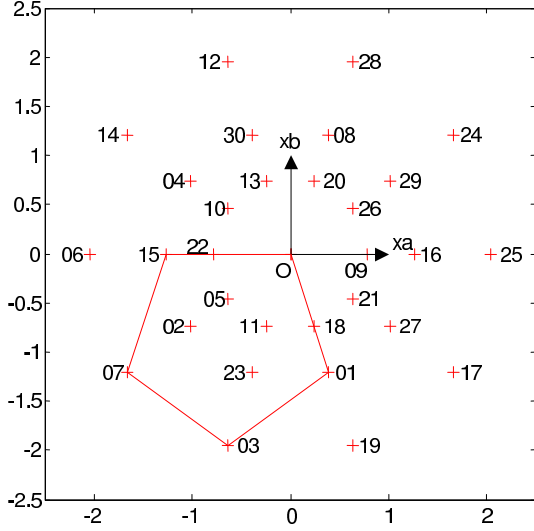

Figure 6: Projections of the voltage vector on the main plane.

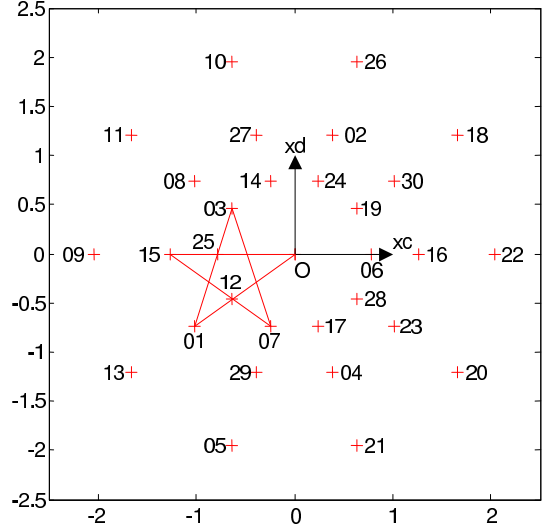

Figure 7: Projections of the voltage vector on the secondary plane.

The voltage vector reference is then:

$$\overrightarrow{\langle v_{ref} \rangle} = \overrightarrow{\langle v_{zref} \rangle} + \overrightarrow{\langle v_{mref} \rangle} + \overrightarrow{\langle v_{sref} \rangle}$$

where $\overrightarrow{\langle v_{zref} \rangle} = \vec{0}$, $\overrightarrow{\langle v_{mref} \rangle}$ belongs to the main plane and $\overrightarrow{\langle v_{sref} \rangle}$ belongs to the secondary plane.

4.2 Computation of the duty cycles

As for the 3-phase system, a natural choice consists in using the family (0, 31) as a triangle intersection PWM does. In this family, there are $5! = 120$ different combinations of six vectors which respect the constraints.

If we take for example the combination of the vectors (0 1 3 7 15 31) shown in red in the figures 6 and 7, the vector $\overrightarrow{\langle v_{ref} \rangle}$ to be synthesized is given by the relation :

$$\overrightarrow{\langle v_{ref} \rangle} = \alpha_0^d \vec{v}_0 + \alpha_1^d \vec{v}_1 + \alpha_3^d \vec{v}_3 + \alpha_7^d \vec{v}_7 + \alpha_{15}^d \vec{v}_{15} + \alpha_{31}^d \vec{v}_{31}$$

By the same way as previously, we can find the relations :

$$\begin{aligned}\alpha_1^n &= \alpha_{31}^d \\ \alpha_2^n &= \alpha_{15}^d + \alpha_{31}^d \\ \alpha_3^n &= \alpha_7^d + \alpha_{15}^d + \alpha_{31}^d \\ \alpha_4^n &= \alpha_3^d + \alpha_7^d + \alpha_{15}^d + \alpha_{31}^d \\ \alpha_5^n &= \alpha_1^d + \alpha_3^d + \alpha_7^d + \alpha_{15}^d + \alpha_{31}^d\end{aligned}$$

4.3 Practical results

This algorithm of computation has been used in a vector current control of a 5-phase synchronous machine. The switches are controlled with a DSPACE board programmed under MATLAB-SIMULINK. The experimental bench is shown in the figure 8 and the structure of the control system in the figure 9. The figures ?? and ?? show the currents in the real and the fictitious machines with the following references:

$$\begin{aligned}\vec{i}_{m_{ref}} &= I_m(\sin(2\pi 10t)\vec{x}_a + \sin(2\pi 10t + \frac{\pi}{2})\vec{x}_b) \\ \vec{i}_{s_{ref}} &= I_s(\sin(2\pi 30t)\vec{x}_c + \sin(2\pi 30t + \frac{3\pi}{2})\vec{x}_d)\end{aligned}$$

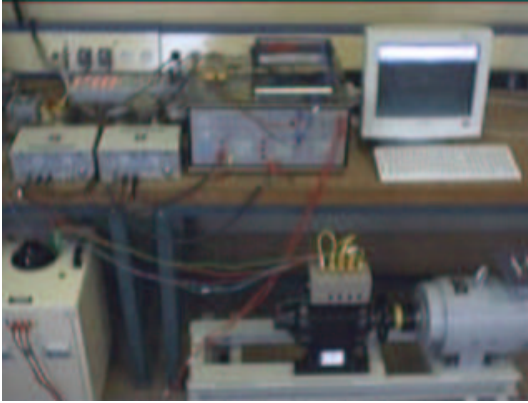

Figure 8: Experimental bench.

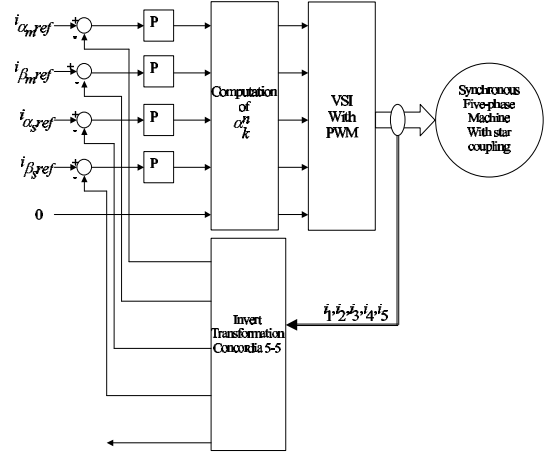

Figure 9: Structure of the proposed control.

We can observe more noisy currents in the secondary fictitious machine than in the main fictitious machine because of the difference between the two time constants.

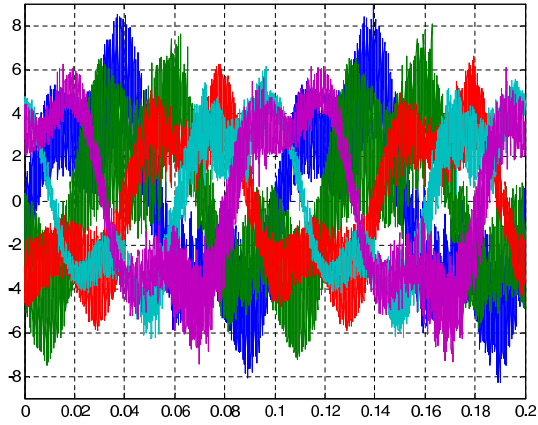

Figure 10: currents of the 5 phases.

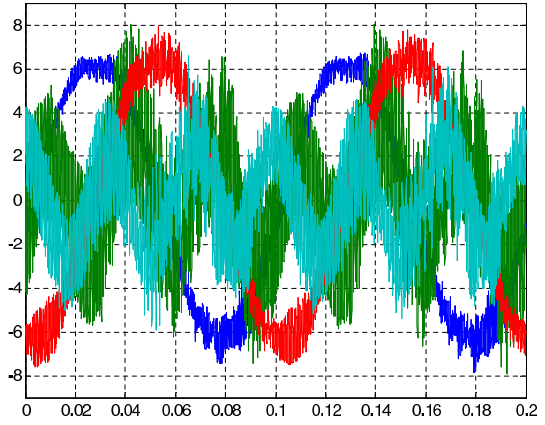

Figure 11: currents of fictitious machines.

5 Conclusion

In the paper a new method to compute the duty cycles of VSI's legs has been exposed. This method does not need to locate the vector in a particular sector and can be implemented with a system with no great capability of computation.

Particular patterns of PWM are used to take into account switching constraints. Other constraints could be chosen for example to generate less parasitic currents in the secondary machine or to work with only four legs.

This work is based on a vectorial modelling of multi-phase systems associated to the Multi-machine Multi-converter System concept which permits the extension to an arbitrary number of phases and for three-level inverters.

References

- [1] X. Kestelyn, E. Semail, J.P Hautier. *Vectorial Multi-machine Modeling for a 5-Phase Machine*. ICEM Brugges, August 2002, CD-ROM.
- [2] Z.Yifan , T. A. Lipo. *Space Vector PWM Control of Dual Three-Phase Induction Maching Using Vector Space Decomposition*. IEEE Transactions on Industry Applications, Vol. 31. no 5, September/October 1995, pp. 1100-1109.
- [3] E. Semail. *Tools and studying method of polyphase electrical systems. Generalization of the space vector theory*. Ph.D. thesis USTL(University of Sciences and Technologies of Lille), June 2000 (text in French).
- [4] H.A. Toliyat, S. Ruhe, X. Huangsheng *A DSP-Based Vector Control of 5-Phase Synchronous Reluctance Motor*. IAS 2000,october 2000, CD-ROM.
- [5] E. Semail, C. Rombaut *New tools for studying voltage-source inverters*. IEEE Power Engineering Review, Vol. 22. no 3, March 2002, pp. 47-48
- [6] J. P. Martin , E. Semail , S. Pierfederici,A. Bouscayrol, F. Meibody-Tabar , B. Davat *Space Vector Control of 5-phase PMSM supplied by q H-bridge VSIs*. ElectrIMACS 2002, Montreal, August 2002, CDROM.
- [7] E. Semail , C. Rombaut *New method to calculate the conduction durations of the switches in a n-leg 2-level Voltage Source*. EPE 2001, 27-29 August, 2001, Graz, Austria,CDROM.
- [8] D. Gondouin,F. Menneron *New diesel-electric propulsion system topologies*. AES2000, October 2000, Paris (France), pp. 66-71.
- [9] A. Hava,R. Kerkman ,T. Lipo, *Carrier-based PWM VSI overmodulation strategies: analysis, comparison and design*, IEEE Trans. on Power Electronics, vol. 13, No. 4, July 1998, pp. 624-689.
- [10] W. Leonhard., *30 years space vectors, 20 years field orientation, 10 years digital signal processing with controlled AC drives*, EPE Journal, vol. 1, No. 1, July 1991, pp. 13-20.
- [11] J. Holtz, *Pulse width modulation - A survey*, IEEE Trans. on Industrial Electronics, vol. 39 no. 5, December 1992, pp. 410-419.
- [12] V. Blasko *Analysis of a hybrid PWM based on modified space vector and triangle-comparison methods*, IEEE Transactions on industry applications, Vol. 33, No. 1, May/june 1997,pp. 756-764.
- [13] E. Semail, A. Bouscayrol,J.P. Hautier *Vectorial formalism for analysis and design of polyphase synchronous machines*, EPJ Applied Physics, EPJ AP (European Physical Journal-Applied Physics), Vol 22 Nr3 2003 pp. 207-220.
- [14] P. Delarue,A. Bouscayrol ,E. Semail *Generic Control Method of Multileg Voltage-Source-Converters for Fast Practical Implementation*, IEEE Trans. on Power Electronics, vol. 18, no. 2, March 2003, pp. 517-526.
- [15] D. Hadiouche,H. Razik,A. Rezzoug *Modelling of a Double Star Induction Motor for Space Vector PWM Control*. ICEM 2000, August 2000, Espoo (Finland) pp. 392-396.
- [16] A. Bouscayrol, B. Davat, B. de Fornel, B. François, J. P. Hautier, F. Meibody-Tabar, M. Pietrzak-David. *Multi-machine Multi-converter System: application for the electromechanical drives*. EPJ Applied Physics, Vol. 10, no. 2, May 2000, pp-131-147, (common paper of GREEN, L2EP and LEEI, according to the MMS project of the French GdR-SDSE).