



### **Science Arts & Métiers (SAM)**

is an open access repository that collects the work of Arts et Métiers Institute of Technology researchers and makes it freely available over the web where possible.

This is an author-deposited version published in: <https://sam.ensam.eu>  
Handle ID: [.http://hdl.handle.net/10985/23286](http://hdl.handle.net/10985/23286)

#### **To cite this version :**

Oussama ADJOUL, Khaled BENFRIHA, Chawki EL ZANT, Améziane AOUSSAT - Algorithmic Strategy for Simultaneous Optimization of Design and Maintenance of Multi-Component Industrial Systems - Reliability Engineering and System Safety - Vol. 208, p.107364 - 2020

Any correspondence concerning this service should be sent to the repository

Administrator : [scienceouverte@ensam.eu](mailto:scienceouverte@ensam.eu)



# Algorithmic Strategy for Simultaneous Optimization of Design and Maintenance of Multi-Component Industrial Systems

Oussama Adjoul, Khaled Benfriha<sup>\*</sup>, Chawki El Zant, Améziane Aoussat

*Ecole Nationale Supérieure des Arts et Métiers, France*

---

## ARTICLE INFO

### Keywords:

Design  
Dynamic maintenance  
Optimization  
Life Cycle Cost (LCC)  
Total Operational Reliability (TOR)  
Multi-component industrial systems

## ABSTRACT

This article describes a new approach to simultaneous optimization of design and maintenance of large-scale multi-component industrial systems. This approach, in a form of an algorithm, aims to help designers in the search for solutions by characterizing the components and their architecture including maintenance issues. The aim is to improve the performance of the industrial systems by maximizing the Total Operational Reliability (TOR) at the lowest Life Cycle Cost (LCC). In the case of this research, the term "design" refers to the reliability properties of the components, possible redundancies, faulty component accessibility, and the ability to improve the component real-time monitoring architecture. The term "maintenance" refers to maintenance plan adapted to the opportunistic dynamic maintenance plan. Simultaneous optimization of design and maintenance is achieved by a two-level hybrid algorithm using evolutionary (genetic) algorithms. The first level identifies the optimal design solutions calculated relative to the TOR and the LCC. The second proposes a dynamic maintenance plan that maximizes the reliability of the system throughout its operating life.

---

## 1. Introduction

Today, new large-scale industrial systems, such as industrial vehicles, aircraft, etc., are becoming increasingly complex. This complexity originates from the diversity of technologies used in the components (electronics, mechanics, sensors, etc.), which once assembled constitute the final product [1]. To control this complexity and win more market share, many manufacturers have evolved into a new economic strategy. They go from selling products to selling services that include the product. In this context, they offer their customers a provisioning package and a billing indexed to its use. It's a matter of the company that manufactures this system to ensure the availability of the service and the product reliability during the contract period.

This evolution introduces the concept of Life Cycle Cost (LCC) covering, the overall operating costs including maintenance. For many complex systems, the maintenance cost is an important component of the LCC [2]. It is worth mentioning that maintenance costs can exceed 65% of the LCC, especially for nuclear power generation plants [3].

Recently, Kusiak and Li., [4] conducted a study saying that the failure of a \$ 5000 wind level can result in a \$ 250,000 maintenance operation. In fact, the replacement of the bearing requires special repair

equipment and a specialized maintenance team, in addition to the loss of electricity production [4]. This work shows the importance of taking maintenance into account in the design stage.

Maintenance is traditionally linked to two factors, the internal one, corresponding to the characteristics of intrinsic reliability and maintainability of the chosen components, and the architecture of the product. The other factor is external, which corresponds to the context of use and the technical and the organizational skills of the end user [1,2].

Generally, decision making for reliability and maintainability design and maintenance planning is handled sequentially or independently. We start by freezing the detailed design and then define the maintenance plan [5]. However, this can be detrimental because these two sets influence each other [6]. Indeed, the product features during design, including reliability and maintainability, strongly influence how the products can be manufactured, used, maintained or disposed [1].

In this perspective, our paper focuses on joint decision making for the design in terms of reliability and maintainability and maintenance in terms of dynamic plan of maintenance operations. The overall goal of this research is to develop a decision support tool that offers solutions to the designer in the form of a Pareto graph. This graph facilitates the convergence towards the best compromise solution according to LCC

---

<sup>\*</sup> Corresponding author at: HDR Arts et Métiers Institute of Technology, Paris, France.

*E-mail address:* [khaled.benfriha@ensam.eu](mailto:khaled.benfriha@ensam.eu) (K. Benfriha).

and Total Operational Reliability<sup>1</sup> (TOR). A compromise Pareto solution means, first of all identify an architecture, then allocate reliability and maintainability to each component of the system, and finally define a maintenance plan in recommendations form to be deployed during the operation phase.

The rest of the article is organized in 7 sections. Section 2 reviews the design for maintenance literature. Section 3 describes the mathematical models used to support the proposed approach. Section 4 presents the method of combinatorial resolution based on genetic algorithms. An example from the literature and a discussion of the results are presented in sections 5 and 6. Section 7 concludes the paper and suggests possible directions for future researches.

## 2. State of the art: Design For Maintenance DFM

The literature proposes a design approach for integrating maintenance into the DFX tools "Design For X" [7]. This concept of the DFX "design for business X" is nothing more than a generalization of the "Design For Assembly" (DFA) tools [8] and "Design For Manufacturing" (DFMf) [9–11]. Business expertise is formalized into design rules to participate in decision-making. These rules are carried by the actors of the design.

Maintenance integration is driven by Design for Sustainability (DFMt), Design For Reliability (DFR), Design For Diagnosability (DFD), or Design for Maintenance (DFM) [2, 7, [12]. The design for reliability strategy is to achieve a highly reliable system that requires little maintenance over its entire lifetime. Design strategies for maintainability and diagnostics both aim to improve the ease and speed which can bring a system back into service after a failure. The concept of "design for maintenance" takes into account the close links between maintenance and design to improve the availability of the system with the most cost-effective over its lifecycle [13]. In what follows, our discussion focuses on these three strategies as well as the analysis of their relevance to improve the reliability, availability and the LCC of the system from a maintenance point of view.

### 2.1. Design for reliability

The optimization of reliability in the design phase has several objectives. It is generally intended to improve the life of an entity, and to reduce the operating costs [2]. According to Zoufaghari et al [14]., there are two general followed approaches to optimize the reliability of the multi-component industrial system. The first, called reliability optimization which considers the reliability of the components as a decision variable. The goal is to find the values that best meet the objectives and constraints required [15]. The second approach, redundancy allocation, tries to find the number of components to apply in each subsystem [16]. This assumes the characteristics of each component such as reliability, weight, cost, etc. are predetermined. The goal is to find the number of components to apply in each subsystem. In most cases, the goal of optimizing redundancy is to maximize reliability [17–19]. These two approaches can be grouped into the category of design for maintenance in favor of reliability [20].

Several recent works [17, 21–23] examine the reliability optimization by combining the two approaches mentioned above or by treating one of them. Most of this works considers maintenance and operating costs in the optimization process as an objective function, sometimes "extra" alongside other more important functions such as reliability, availability. In other cases, it is considered as a decisive fundamental function.

We refer to the paper of Yao et al., [24] who proposed a joint optimization model of redundancy and maintenance based on inspection. The main objective of this model is to define an optimal system structure

and inspection policy for each component, which maximize the performance of the series-parallel system while taking into account the constraints of reliability and costs. Atashgar and Abdollahzadeh., [25] developed a method for jointly optimizing the redundancy and opportunistic maintenance of a wind farm. Goel et al. [5] have developed a reliability allocation model. This model attempts to combine the optimization of maintenance with production and design. Valdebenito and Schuëller., [26] presented a reliability allocation model that minimizes the total cost of maintenance under reliability constraints. Rawat and Lad., [6, 27, 28] presented a method that considers two approaches to optimize reliability : allocating reliability and allocating redundancy for multi-component systems. This work attempts to combine the optimization of maintenance with production and design.

### 2.2. Design for maintainability

Several recent works [12, 29] deal with improving system maintainability characteristics in the design phase, including detailed design, logistical support and ergonomics. The objective of this work is to evaluate and optimize the maintainability via the MTTR<sup>2</sup> rate. Optimizing the MTTR is to take into account some criteria, such as accessibility or demonstrability, individually or combined during the product design [12]. Improving the maintainability of a component, for example its accessibility, requires design changes which increase the cost of the system [30].

### 2.3. Design for diagnosability

As the products become more and more complex, the detection of failures becomes more difficult and takes more time. To minimize the time for detecting failures, numerous studies have used self-diagnostic systems (sensors) [29, 31–33]. Systems that continuously measure performance gaps by monitoring the deterioration of these components make it easier to predict failures and determine the right time to perform maintenance [34]. As a result, condition-based maintenance (dynamic maintenance) has been widely used as an effective maintenance strategy [35].

In the literature, numerous works developed this dynamic maintenance plan. Castanier et al., [36] proposed a conditional based maintenance plan for a system containing two components. OldeKeizer et al., [37] proposes a dynamic maintenance model for multi-component systems which present both redundancies and economic dependencies. Wildeman et al., [38] proposes a dynamic maintenance model over a rolling horizon. To set up this model, it is first necessary to define the optimal maintenance date for each component taken individually. Then, for each component, a penalty function is constructed.

Based on the rolling horizon approach, Bouvard et al., [39] suggests using this method for multi-component systems with gradual degradation. The idea is to use the information related to the current state of the components to update the maintenance schedule. In other works, the rolling horizon approach has been completed to take into account time constraints [40] but also constraints related to the number of repairers available [41]. However, these contributions are related only to multi-component systems with series structures. Recently, work has made it possible to adapt this dynamic grouping plan in order to take into account systems with a more elaborate structure that can mix series / parallels connections [42, 43].

Still in the context of dynamic maintenance, Lesobre et al., [34, 44] have developed a dynamic maintenance plan for multi-component systems based on the concept of Maintenance Free Operating Period (MFOP) in order to group maintenance operations, that is used in this article. Unlike the majority of dynamic grouping policies from the literature, maintenance opportunities are not decided by the

<sup>1</sup> The product reliability in the operation phase

<sup>2</sup> MTTR: Mean Time To Repair

components but rather by the state of the system. This form of dynamic grouping is based on a decision-making process which is based both on the stochastic models of the components, on the structure of the system, on the economic dependencies, and on the degradation information of the components available online.

The implementation of a dynamic maintenance plan requires additional resources dedicated to the development of a surveillance architecture. It often requires a significant investment. In addition, there are cases where the installation of monitoring systems is difficult to implement or does not provide additional information on the system state (for example the case of microelectronic systems). Therefore, the technical and economic feasibility of implementing monitoring systems must be assessed from the design of the entity.

#### 2.4. Resolution method

In terms of numerical optimization methods, we have found that heuristic and meta-heuristic methods such as Genetic Algorithm (GA), Simulated Annealing (SA) and Particle Swarm Optimization (PSO), have been widely applied in this area [45, 46]. The goal is to maximize or minimize certain parameters such as, cost, reliability, availability, maintenance time, weight, etc. According to Almeida et al., [47] 68.3% of works under this theme aim to minimize cost, 37.6% to maximize reliability, 17.2% to maximize availability, 11.8% to minimize maintenance time and 15.7% for the remaining (weight, volume, etc.).

Monga and Zuo., [48] have considered the design problem for reliability. They proposed an optimization model to minimize the cost of the system life cycle, depending on reliability requirements. Their model uses genetic algorithms to solve the optimization problem.

#### 2.5. Observations from the literature

From the state of the art on design methods for maintenance, four observations are pointed:

- 1 There are no available methods for concurrent characterization of the four design approaches for maintenance (allocation of reliability, redundancy, maintainability and diagnostics).
- 2 All design approaches for maintenance must be validated by reliability analysis and cost over the entire life cycle of the system. The challenge is to find the best compromise between improving the reliability and maintainability characteristics of the system and the gains achieved on operating costs.
- 3 Issues related to the design and maintenance of industrial systems are usually dealt with sequentially or independently.
- 4 It is interesting to know whether the investments made for the monitoring architecture are compensated by benefits obtained in terms of maintenance. It is therefore necessary to base the implementation choice of monitoring systems on an LCC analysis, right from the design stage.

From this analysis, we developed a new approach for simultaneous optimization of design and maintenance. To optimize the design of multi-component industrial systems, the designer can choose the reliability level of its components, the architecture of the system, in particular the redundancy. He can work on maintainability to make some components more accessible for example, or install monitoring systems to detect and anticipate failures. The maintenance optimization focuses on the development of a dynamic maintenance plan.

### 3. Simultaneous optimization of design and maintenance approach

The design and maintenance optimization approach of systems consisting of  $n$  independent components is organized in three steps. The first step is to model the different possible design solutions by defining

their design parameters, structures and characteristics. The second step defines all possible maintenance plans for each design solution. Each maintenance plan organizes and sets the maintenance operations according to the desired objectives and the existing constraints. The last step is to assess the different design solutions and possible maintenance plans generated in the two previous steps according to their objectives.

In this article two objectives are considered, the minimization of the LCC and the maximization of the TOR. The evaluation models for these two objectives are detailed in sections 3.3.1 and 3.3.2. Finally, the approach selects design solutions that maximize the TOR and in the same time generates the lowest LCC. Besides, it adds the maintenance plan to be deployed during the operating phase.

#### 3.1. Design modelling

In this work, the design modelling is based on four design parameters for maintenance. For each component  $i$  ( $i=1, \dots, n$ ) of a multi-component system, we can mention the choice of its level of reliability ( $R_i$ ), the choice to invest in a more powerful monitoring instruments by the implementation of a sensor ( $S_i$ ), the choice to consider a redundant component ( $P_i$ ) and the choice of its accessibility level ( $MTTR_i$ ).

Determining the number of design parameters available to the designer and their range of values for each component is potentially the most complex part. So, the designer must first assess the technical viability of these four parameters for each component. For example, it may be impossible to install a sensor on a given component or to make it more accessible in the system. Then, based on the results of this technical analysis, the number of design parameters of each component and their range of values are defined. In the end, several solutions of the system, referred to as  $S_p$  ( $p=1, \dots, N$ ) with  $N$  is the number of possible solutions are obtained, which vary according to their design parameter ( $R_i, P_i, MTTR_i$  and  $S_i$ ). We define a design solution as a particular choice of design parameters.

#### 3.2. Maintenance modelling

In this work, we rely on the MFOP concept, proposed by the Royal Air Force in 1996.

##### 3.2.1. MFOP concept

Hockley defines the MFOP as an operation period when the equipment must be able to carry out its tasks without maintenance action and without restricting the operator for failures reasons [49]. Each MFOP is usually followed by a Maintenance Recovery Period (MRP). MRP is defined as the period while the appropriate maintenance is performed on the system enabling it to successfully complete the next MFOP [50, 51]. The shutdown period will depend on the maintenance work to be performed [52]. In practice, it is obviously impossible to guarantee 100% that no failure will occur on the next MFOP, we must therefore assess this risk with the Maintenance Free Operating Period Survivability (MFOPS). MFOPS is defined as the probability that the system will survive on the duration of the MFOP ( $t_{MFOP}$ ) knowing that it was in an operational state at the beginning of the period [51]. Its mathematical formula is given by:

$$MFOPS_{sys}(t) = \frac{R_{sys}(t + t_{MFOP})}{R_{sys}(t)} \quad (1)$$

where  $R_{sys}(t)$  is the system reliability after  $t$  life units. The reliability model is detailed in section 3.3.2.

##### 3.2.2. Dynamic maintenance plan

The term dynamic means that the maintenance decision is adapted through the monitoring information available online on the component status  $H_{i,t}$  ( $i=1, \dots, n$ ). As a result, the mathematical formula of the  $MFOPS_{sys}(t)$  becomes:

$$MFOPS_{sys}(t) = \frac{R_{sys}(t + t_{MFOP} / H_{i,t(i=1 \text{ à } n)})}{R_{sys}(t / H_{i,t(i=1 \text{ à } n)})} \quad (2)$$

This information can be quantitative (degradation measurement) or qualitative ("Working mode" / "Failure mode"). This means  $S_i=1$  at the design parameter level. For this purpose, Lesobre et al., [34] propose three levels of information that we will use in our approach. Level 1: No information; Level 2: Operating Status Information On / Off; Level 3: Degradation Measure.

The different values taken by  $R_i(t/H_{i,t})$  and  $R_i(t + t_{MFOP}/H_{i,t})$ , namely the reliability of component  $i$  at the beginning and the end of each MFOP depending on its level information availability  $H_{i,t}$ , are:

Level 1 when  $H_{i,t} = \Phi$ , in this case we have:

$$\begin{cases} 1 & \text{if the component } i \text{ is replaced at the beginning of the MFOP}_j \text{ period (maintenance stop } j); \\ 0 & \text{otherwise.} \end{cases}$$

- $R_i(t/H_{i,t}) = R_i(t)$
- $R_i(t + t_{MFOP}/H_{i,t}) = R_i(t + t_{MFOP})$

Level 2 with  $H_{i,t} = \text{"Failed"}$ , in this case we have:

- $R_i(t/H_{i,t}) = 0$
- $R_i(t + t_{MFOP}/H_{i,t}) = 0$

Level 2 when  $H_{i,t} = \text{"Working"}$ , and so:

- $R_i(t/H_{i,t}) = 1$
- $R_i(t + t_{MFOP}/H_{i,t}) = \frac{R_i(t + t_{MFOP})}{R_i(t)}$

Level 3 when  $H_{i,t} = Z_i(t) > L$ , in which case the component is failed, and we have:

- $R_i(t/H_{i,t}) = 0$
- $R_i(t + t_{MFOP}/H_{i,t}) = 0$

Level 3 when  $H_{i,t} = Z_i(t) < L$ , in which case the component is working, and we have:

- $R_i(t/H_{i,t}) = 1$
- $R_i(t + t_{MFOP}/H_{i,t}) = R_i(t + t_{MFOP}/Z_i(t))$

where  $Z_i(t)$  is the degradation function of component  $i$  and  $L$  is the degradation limit.

Figure 1 illustrates for a possible design solution  $Sl_p$ , the decision process for developing dynamic maintenance plan, referred to as  $MP_{py}$  ( $y=1, \dots, M$ ) with  $M$  as the number of possible maintenance plan, for the

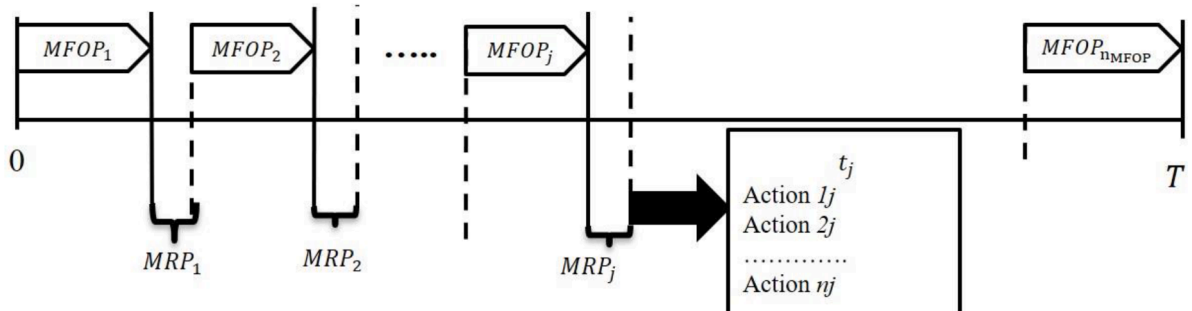

Figure 1. Dynamic Maintenance plan based on the MFOP concept.

solution  $Sl_p$ . This plan, based on the MFOP concept, is organized into two steps:

**The first step** consists of defining the dates of the maintenance stops  $t_j$ , the duration  $t_{MFOP_j}$  of each period  $MFOP_j$  and the total number of maintenance stops  $N_{MS}$  over the entire operating life  $T$ . It should be noted that the date  $t_j$  of a maintenance stop represents the end of an MFOP period (preventive stop) or the occurrence of a failure (corrective stop) in the system.

**The second step** consists in selecting the maintenance actions  $X_{ij}$  to be performed at each maintenance stop event  $j$  on each component  $i$ . Noting that  $X_{ij}$  can take two values:

In this article, a dynamic maintenance plan is considered possible, only if the maintenance recovery period at each stop  $j$  does not exceed a threshold  $MRP_{max}$  given by:

$$MRP_j = \sum_{i=1}^n MTTR_i X_{ij} \quad (3)$$

In this context, a constraint optimization problem can be formulated mathematically as follows:

$$\max_{\{X_{ij}\}} MFOPS_{sys_j}, j = 1, \dots, n_{MFOP} \quad (4)$$

$$\text{s.t. } MRP_j \leq MRP_{max}$$

Where  $n_{MFOP}$  is the number of MFOP performed by the system on  $[0, T]$ ,  $MRP_{max}$  the maximum maintenance recovery period authorized to perform a set of operations  $\{X_{ij}\}$  during a maintenance time.

Finally, note that more accurate the information is, the better is the maintenance prediction.

Thus, over the entire operating life  $T$ , the end of period  $MFOP_j$  and the beginning of period  $MFOP_{j+1}$  can be confused. This is because  $MRP_{max}$  is so small compared to all periods  $MFOP_j$  that we have not added it in the  $T$  That is to say, calculate in relation to  $T$  instead of  $T + \sum_{j=1}^{n_{MFOP}} MRP_j$ .

### 3.3. Simultaneous evaluation and selection

After generating possible design solutions, as well as their possible maintenance plans, we must now define the evaluation objective in order to select a compromised solution (design solution and the associated maintenance plan). In this article two goals are considered, LCC

and TOR to select an optimal design. However, to select a dynamic maintenance plan, we consider one goal, TOR. The evaluation of these objectives usually requires numerical evaluation methods, such as Monte Carlo method.

### 3.3.1. LCC assessment model

The LCC of multi-component industrial systems typically includes two types of costs; deterministic costs (such as capital costs, disposal costs, etc.) and probabilistic costs (such as maintenance costs, spare parts, gross margin loss, etc.) [53]. However, in this manuscript as in the work of Hwang [54] and Okasha et al., [18], the life-cycle cost of multi-component industrial systems is limited to initial costs (initial investments)  $IC$  and total maintenance costs  $TMC$ . Its mathematical formula is:

$$LCC(T)_{\text{sys}} = IC + TMC(T) \quad (5)$$

The initial costs of the system, corresponding to:

$$IC = \sum_{i=1}^n (C_i + C_{s,i}) \quad (6)$$

Where  $C_i$  is the cost of the component  $i$  and  $C_{s,i}$  represents the cost related to the information available on component  $i$  (example: cost of a sensor).

The total updated maintenance cost  $TMC(T)$  is given by:

$$TMC(T) = \sum_{k=1}^{n_{ps}} \frac{C_{prev_k}}{(1+\nu)^{tp_k}} + \sum_{q=1}^{n_{cs}} \frac{C_{cor_q} + C_{dia_q}}{(1+\nu)^{tc_q}} \quad (7)$$

Where  $C_{prev_k}$  represents the cost of preventive maintenance stop  $k$ ,  $n_{ps}$  is the number of preventive maintenance stops of the system on  $[0, T]$ ,  $tp_k$  is the date of preventive maintenance stop  $k$ ,  $\nu$  is the discount rate,  $C_{cor_q}$  is the cost of corrective maintenance stop  $q$ ,  $n_{cs}$  is the number of corrective maintenance stops of the system on  $[0, T]$ ,  $tc_q$  is the date of corrective maintenance stop  $q$ , and finally  $C_{dia_q}$  is the additional cost related to the diagnosis when the system is in the corrective maintenance.

The undiscounted cost of preventive maintenance stop  $C_{prev_k}$  corresponds to:

$$C_{prev_k} = \sum_{i=1}^n (C_i + MTTR_i * \tau_o) * \delta_{i,k} + C_{plog} \quad (8)$$

Where  $\delta_{i,k}$  is a boolean equal to 1 if the component  $i$  is replaced during the preventive maintenance stop  $k$ , 0 otherwise,  $\tau_o$  is the hourly rate of labor,  $C_{plog}$  is the logistics cost linked to preventive maintenance stops.

The undiscounted cost of corrective maintenance stop  $C_{cor_q}$  is given by:

$$C_{cor_q} = \sum_{i=1}^n ((C_i + MTTR_i * \tau_o) + (MTTR_i * \tau_{immob})) * \delta_{i,q} + (C_{clog} + (D_{clog} * \tau_{immob})) \quad (9)$$

Where  $\delta_{i,q}$  represents a boolean equal to 1 if the component  $i$  is replaced during the corrective maintenance stop  $q$ , 0 otherwise,  $\tau_{immob}$  is the loss per system downtime,  $D_{clog}$  is the logistic duration related to the corrective maintenance stop,  $C_{clog}$  is the logistic cost related to the corrective maintenance stop.

Note that the  $\delta_{i,k}$  and the  $\delta_{i,q}$  can be linked with  $X_{ij}$  as follows:

- $X_{ij} = \delta_{i,k}$  if the maintenance action is preventive;
- $X_{ij} = \delta_{i,q}$  if the maintenance action is corrective.

During a corrective shutdown, the diagnostic system identifies the component(s) responsible for the failure in order to guide the maintenance actions. For some components, the available monitoring infor-

mation provides information about how they work. In this case, no additional cost of diagnosis will be counted. Conversely, for components whose operating status is unknown, a test must be carried out generating additional costs. These costs will be taken into account in the expression  $C_{dia_q}$  given by:

$$C_{dia_q} = (C_{UD} + (D_{UD} * \tau_{immob})) * n_{sis} \quad (10)$$

Where  $C_{UD}$  is the unit diagnostic cost for a component,  $D_{UD}$  is the unit diagnostic time for a component, and finally  $n_{sis}$  is the number of components in the system whose monitoring information is not available. We therefore choose to count the diagnosis only during the system failure on unmonitored components. In other situations, we assume that the costs related to the diagnosis are taken into account in the cost of the monitoring architecture, not in the  $TMC(T)$ .

### 3.3.2. TOR assessment model

In this article, we define the TOR of the system, referred to as  $TOR_{\text{sys}}(T)$ , as the mean of all  $MFOPS_{\text{sys}_j}$  because, the system performs a succession of periods of duration  $t_{MFOP_j}$ . Equation (11) gives the  $TOR_{\text{sys}}$  as a function of  $MFOPS_{\text{sys}_j}$ :

$$TOR_{\text{sys}}(T) = \frac{\sum_{j=1}^{n_{MFOP}} MFOPS_{\text{sys}_j}}{n_{MFOP}} \quad (11)$$

However, the process of maximizing the  $MFOPS_{\text{sys}_j}$  is to maximize the  $TOR_{\text{sys}}(T)$  and to ensure that each  $MFOPS_{\text{sys}_j}$  is infinitely close to the  $TOR_{\text{sys}}(T)$ , i.e. minimize the variance, which is given by the following formula:

$$\begin{aligned} Var(MFOPS_{\text{sys}_j}) &= \frac{1}{n_{MFOP}} \sum_{i=1}^{n_{MFOP}} (MFOPS_{\text{sys}_j} - TOR_{\text{sys}}(T))^2 \\ &= \left( \frac{1}{n_{MFOP}} \sum_{i=1}^{n_{MFOP}} (MFOPS_{\text{sys}_j}^2) \right) - TOR_{\text{sys}}(T) \end{aligned} \quad (12)$$

This process will allow us to have a single maximum value for the reliability of the system over its entire lifetime.

Looking now at the evaluation of the  $MFOPS_{\text{sys}_j}$  ( $j = 1, \dots, n_{MFOP}$ ). We defined it previously as the ratio of the system reliability at the end of the period  $j$  ( $R_{\text{sys}}(t_j + t_{MFOP_j})$ ) over the reliability of the system at the beginning of this period  $j$  ( $R_{\text{sys}}(t_j)$ ), considering the available information  $H_{i,t_j}$  at  $t_j$ . Thus, its mathematical formula is given by:

$$MFOPS_{\text{sys}_j} = \frac{R_{\text{sys}}(t_j + t_{MFOP_j} / H_{i,t_j(i=1 \text{ à } n)})}{R_{\text{sys}}(t_j / H_{i,t_j(i=1 \text{ à } n)})} \quad (13)$$

To evaluate the reliability of a multi-component system over the interval  $[0, t]$ , the first step is to evaluate the reliability of each component over this interval. Then, depending on the relationships between the components (parallel or serial) of the system, the evaluation of the reliability of the system  $R_{\text{sys}}(t)$  can be established. The application of the reliability calculation expressions at these two basic subsystems makes it possible to evaluate the reliability of the complete system  $R_{\text{sys}}(t)$  over the interval  $[0, t]$ . The following expressions provide the reliability of serial and parallel structure [55].

$$\text{Parallel structure system } R_{\text{sys}}(t) = 1 - \prod_{i=1}^m (1 - R_{A_i}(t)) \quad (14)$$

$$\text{Serial structure system } R_{\text{sys}}(t) = \prod_{i=1}^m R_{A_i}(t) \quad (15)$$

Where  $m$  is the number of components of the structure and  $R_{A_i}(t)$  is the reliability of each component  $i$ .

In the case of having two-component parallel system, the  $MFOPS_{\text{sys}_j}(t)$  over the period  $MFOP_j$  becomes:

$$MFOPS_{sys_j}(t_j) =$$

$$\frac{1 - ((1 - R_1(t_j + t_{MFOP_j}/H_{1,t_j})) \cdot (1 - R_2(t_j + t_{MFOP_j}/H_{2,t_j})))}{1 - ((1 - R_1(t_j/H_{1,t_j})) \cdot (1 - R_2(t_j/H_{2,t_j})))} \quad (16)$$

Where  $R_1(t)$  and  $R_2(t)$  are the reliability at time  $t$  of components 1 and 2 respectively.  $H_{1,t_j}$  and  $H_{2,t_j}$  are the information available at time  $t_j$  of component 1 and 2 respectively.

### 3.3.3. Mathematical formulation

Finally, note that this simultaneous design and maintenance modeling, discussed above, can be formulated as a problem of multi-objective optimizations under the constraints given in equation 16. The mathematical formulation of this problem can be given as follows:

$$\text{Minimize } \{ LCC_{sys}, -MFOPS_{sys_j} \}$$

$$\text{under constraints } \left\{ \begin{array}{l} R_{i_{min}} \leq R_i \leq R_{i_{max}} \\ MTTR_{i_{min}} \leq MTTR_i \leq MTTR_{i_{max}} \\ C_{i_{min}} \leq C_i \leq C_{i_{max}} \\ 0 \leq t_i \leq t_m \\ P_i \in \{0, 1, 2, \dots\} \\ S_i \in \{0, 1\} \\ X_{ij} \in \{0, 1\} \\ MRP_j \leq MRP_{max} \\ i = 1, 2, \dots, n \\ j = 1, 2, \dots, n_{MFOP} \end{array} \right. \quad (17)$$

Where  $C_{i_{min}}$  and  $C_{i_{max}}$  are the minimum and maximum investment costs of the component  $i$ . The purpose of these constraints is to limit the number of possible solutions.

To solve this multi-objective optimization problem, we use genetic

algorithms because, they are adapted for optimization problems with several objectives and / or constraints, and to effectively handle different variables [56]. For this reason, a hybrid algorithm, based on genetic algorithms, at two levels, is developed in the following section.

## 4. Resolution method: Hybrid Algorithmic Tool (HAT)

We are proposing, here, a hybrid optimization tool for design and maintenance based on genetic algorithms. This hybrid algorithmic tool (HAT) combines two dependent algorithms, a main algorithm and a secondary one. The main algorithm, based on the Non-Dominated Sorting Genetic Algorithm II (NSGA-II) method, ensures design optimization in terms of reliability ( $R_i$ ), redundancy ( $P_i$ ), monitoring architecture ( $S_i$ ) and accessibility characterized by the  $MTTR_i$  (solving the problem described by equation (17)). The output of this algorithm represents all the optimal solutions that maximize the Mean Total Operational Reliability, noted  $TOR_{sys}^{mean}(T)$ , and minimize the Mean Life Cycle Cost, noted  $LCC_{sys}^{mean}(T)$ , of a given system. These design solutions constitute a Pareto frontier. The secondary algorithm determines an optimal dynamic maintenance plan, based on the MFOP, by maximizing the  $TOR_{sys}^{mean}(T)$  of each solution (problem described by equation (4)).

The operating process of the Hybrid Algorithmic Design and Maintenance Optimization tool has been implemented as shown in Figure 2:

### Step 1. Generation of design solutions

This step consists of generating the possible design solutions  $Sl_p$  ( $p=1, \dots, N$ ) by adjusting the four design parameters for each component  $i$  under the resource constraints.

### Step 2. Evaluation of possible design solutions $Sl_p$

This step aims to evaluate the  $LCC_{sys}^{mean}(T)$  and the  $TOR_{sys}^{mean}(T)$  of each possible solution  $Sl_p$  equations (5) and ((11)). For this purpose, the

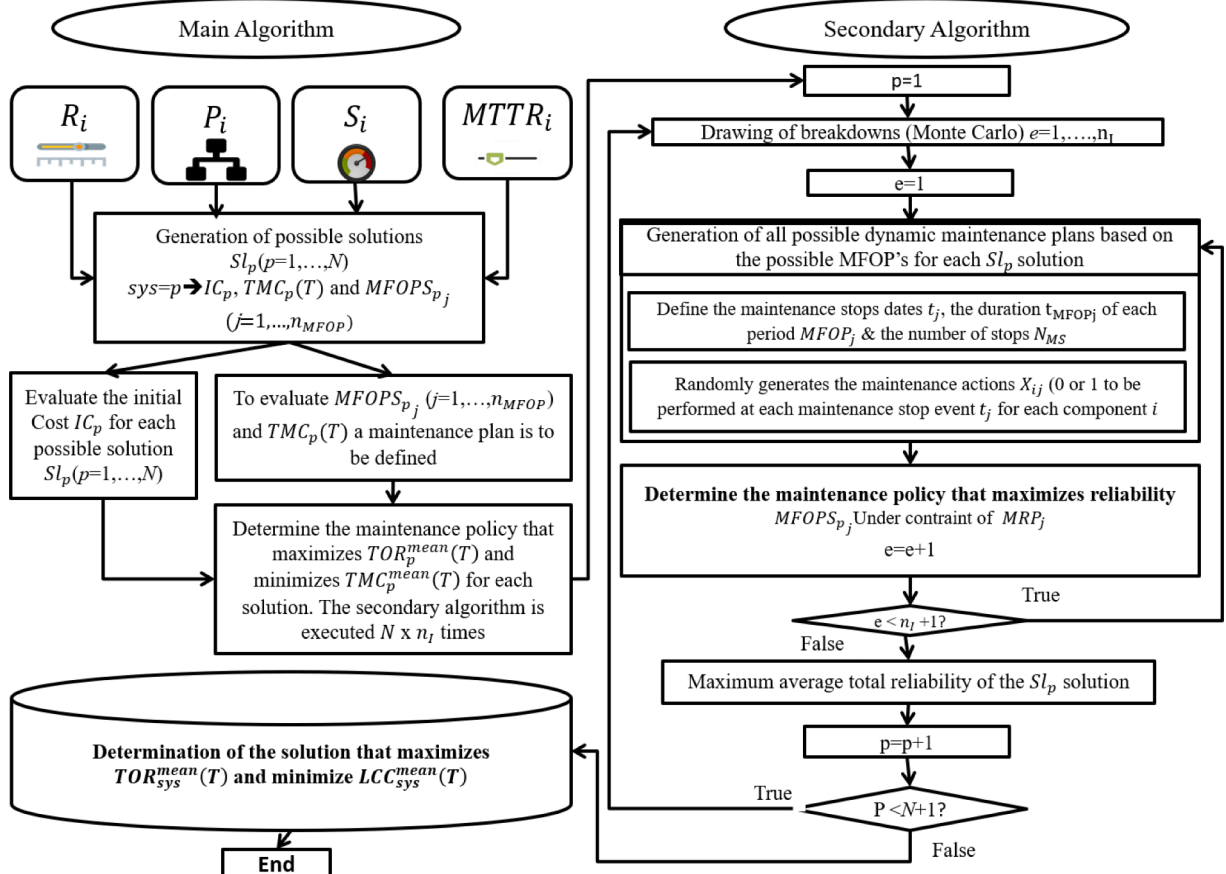

Figure 2. Operating process of the HAT.

secondary algorithm is executed  $n_t$  iterations of Monte Carlo.

### Step 2.1. Generating failures

The objective of this step is to simulate the dynamic behavior of each  $Sl_p$  solution in the operating phase in terms of failures. This is done by a Monte Carlo simulation that generates random failures. To guarantee the convergence of the results, it is recommended to use a large number of iterations ( $n_t$ ). The accuracy of the simulations is strictly proportional to the number  $n_t$  considered.

The process for generating failure times is as follows:

The first step consists of randomly obtaining a *rand* value between 0 and 1, for each component, according to a uniform law. This step is provided by the Rand function of Matlab.

The second step aims to calculate the failure time of each component from this random value and according to the inverse of the law of statistical distribution of reliability. For example, for a component whose reliability model follows a Weibull law with a shape parameter  $\eta$  and a scale parameter  $\lambda$ , the failure times are generated by the following formulation:

$$t_{\text{faul}_i} = -\lambda (\log \text{rand})^{\frac{1}{\eta}} \quad (18)$$

These two steps are finally applied iteratively until the sum of the failure times for each component is reached or exceeds the simulation time  $T$ .

The last step, depending on the structure of the multi-component system and the failure times generated previously, we consider that the system is down or not.

### Step 2.2. Generation of dynamic maintenance plans $MP_{py}$

The secondary algorithm consists, first, at defining the dates of the maintenance stops  $t_j$ , the duration  $t_{MFOP_j}$  of each period  $MFOP_j$  and the number of maintenance stops. Then generate possible maintenance plans  $MP_{py}$  ( $y=1, \dots, M$ ) for each possible solution  $Sl_p$  (section 3.2) and adjusting the  $X_{ij}$  maintenance actions to be performed on each component  $i$ .

### Step 2.3. Selecting optimal dynamic maintenance plans $MP_{po}$

The third step aims, first, to evaluate and classify the generated maintenance plans using the decision criteria, the  $TOR_{\text{sys}}(T)$ , the  $MFOPS_{\text{sys}_j}$ , the variance  $Var(MFOPS_{\text{sys}_j})$  and  $MRP_j$  equations (3), (7) and (11) - (13)). Then, for each possible solution ( $Sl_p$ ), it selects the  $MP_{po}$  maintenance plan that maximizes the  $TOR_{\text{sys}}(T)$ . Furthermore, the reliability  $MFOPS_{\text{sys}_j}$  over each period  $j$  is close to the calculated total reliability  $TOR_{\text{sys}}(T)$ .

Steps 2.2 and 2.3 are finally applied in an iterative way until the iteration number ( $n_t$ ) of the Monte Carlo simulation is reached.

### Step 2.4. Evaluation of the $TOR_{\text{sys}}^{\text{mean}}(T)$ , the $TMC_{\text{sys}}^{\text{mean}}(T)$ and the $LCC_{\text{sys}}^{\text{mean}}(T)$

The final step is to calculate the Mean Total Maintenance Cost, referred to as  $TMC_{\text{sys}}^{\text{mean}}(T)$ , and the  $TOR_{\text{sys}}^{\text{mean}}(T)$  of each possible solution ( $Sl_p$ ). These values can be obtained by averaging the results of  $n_t$  iterations. These can be given mathematically as follow:

$$TOR_{\text{sys}}^{\text{mean}}(T) = \frac{\sum_{e=1}^{n_t} TOR_{\text{sys}_e}}{n_t} \quad TMC_{\text{sys}}^{\text{mean}}(T) = \frac{\sum_{e=1}^{n_t} TMC_{\text{sys}_e}}{n_t} \quad (19)$$

The  $LCC_{\text{sys}}^{\text{mean}}(T)$  may be given by:

$$LCC_{\text{sys}}^{\text{mean}}(T) = IC_{\text{sys}} + TMC_{\text{sys}}^{\text{mean}}(T) \quad (20)$$

### Step 3. Selection of optimal solutions (Pareto set)

The final step in the main algorithm is to classify the different solutions based on their  $TOR_{\text{sys}}^{\text{mean}}(T)$  and their  $LCC_{\text{sys}}^{\text{mean}}(T)$ , in order to select the ones that have the best compromise. These selected solutions thus constitute a Pareto frontier that will allow the design team to choose a solution according to their objectives.

Finally, note that these two algorithms, main and secondary, of the HAT were implemented using the MATLAB programming language toolbox. Therefore, convergence is ensured by a fixed number of

iterations, used as a stopping criterion. All the necessary parameters, including the number of iterations, for the execution of the two algorithms are defined in the section 6.

In addition, both algorithms use a strategy that limits the search for solutions in the area of possible solutions, since there is not an exhaustive enumeration of all possible solutions.

## 5. Numerical Example

In this section, the goal is to test HAT tool and develop a support mapping to select an optimal design solution. In this context, we present, initially, the reference system considered and the simulation hypothesis. Then we finish with the results and their interpretations.

For this example, we will take a multi-component system consisting of five (05) serial components, whose data are a combination of those applied in [34, 44]. Figure 3 illustrates the structure of the system under study.

For this reference system, we assume that the cost and the unit duration of diagnosis are respectively  $C_{UD} = 20\text{€}$  and  $D_{UD} = 5$  min. The hourly rate of labor is fixed at  $\tau_O = 90\text{€}$  and the operating loss per hour of immobilization at  $\tau_{\text{immob}} = 150\text{€}$ . The logistic costs related to preventive and corrective maintenance stops are respectively  $C_{\text{plug}} = 100\text{€}$  and  $C_{\text{clog}} = 150\text{€}$  for a fixed duration  $D_{\text{clog}} = 5\text{h}$ .

Table 1 summarizes the design parameters ( $R_i, P_i, MTTR_i, S_i$ ) of different components of the reference system considered in this example.

We also introduce hypothesis about the reference system, to define the necessary parameters for the simulation:

- ∅ The implementation and the adjustment of the four parameters ( $R_i, P_i, MTTR_i, S_i$ ) is possible for each component  $i$ .
- ∅ The parameters  $R_i$  and  $MTTR_i$  are real and  $c$  with max and min values vary between -50% and + 50% of the reference system values.
- ∅ The installation of sensor on the components  $i = 1, 2, 3$  and 4 gives only information about operation or failure of the component (when  $S_i = 1$ ). Conversely, on component 5, the sensor provides information on its degradation (always  $S_i = 1$ ).
- ∅ Parameters  $P_i$  and  $S_i$  are discrete integers that can only take the value of 0 or 1.
- ∅ The properties of  $A_i$  and  $A'_i$  (its component in parallel) are assumed to be identical.
- ∅ The installation of a sensor will result in a cost  $C_{s,i} = 50\text{€}$ .
- ∅ The cost of each component  $i$  must not exceed 1000 €.

Note finally that the information on the operation / failure state of the system is assumed to be known. This hypothesis is realistic if we consider that the failure of the system systematically causes a breakdown.

In order to demonstrate the relevance of the proposed approach, the following section will present a full analysis of the results obtained on the example detailed here.

## 6. RESULTS AND DISCUSSION

Based on the system properties and the hybrid design and maintenance multi-objective optimization tool, Monte Carlo simulations are implemented to evaluate the  $TOR_{\text{sys}}^{\text{mean}}(T)$  and the  $LCC_{\text{sys}}^{\text{mean}}(T)$ . The simulation horizon is set at 5 years. We also consider that the annual mileage is set at 100,000 km. We assume that the MFOP is fixed at six

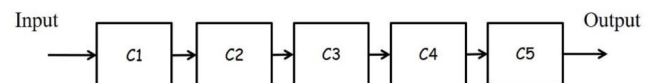

Figure 3. Structure of the multi-component reference system [34, 44].



**Table 1**

Reference system design parameters (W= Weibull distribution, G=Gamma process and L=Degradation Limit) [34, 44].

	C1	C2	C3	C4	C5
Reliability model $R_i$	W (2.8e5,10)	W (3.5e5,8)	W (5e5,11)	W (4.5e5,9)	G(8e- 5,1.5) ;L = 20
$D_i(h)$ MTTR <sub>i</sub>	1.2	1.4	1	1.5	1.7
$S_i$	0	0	0	0	0
$P_i$	0	0	0	0	0
$C_i(\text{€})$	305	311	458	407	302

**Table 2**

execution parameters of the two algorithms.

Parameters	Crossover rate	Mutation rate	Population size	Number of iterations
Main algorithm (NSGA II)	0.5	0.2	100	100
Secondary algorithm (GA)	0.5	0.2	100	200

months, which corresponds to a mileage of 50,000 km. Finally, the maximum maintenance operations time  $MRP_{max}$  is fixed at 3h.

The primary and secondary algorithms of the HAT tool have been implemented using the MATLAB programming language. Table 2 presents the parameters for NSGA II and GA.

Figure 4 shows a Pareto curve where each point represents an optimal design solution, so-called compromise solution, in terms of mean lifecycle cost and  $TOR_{sys}^{mean}(T)$ .

In order to show the effectiveness of this method, we will compare the new solutions generated by our algorithm with the reference solution from published research work. Table 3 shows 3 optimal design solutions chosen arbitrary on the Pareto graph, noted respectively  $Sl_{x1}$ ,  $Sl_{x2}$  and  $Sl_{x3}$  as well as the reference solution noted  $Sl_0$ . We note that with the same constraints, the solutions generated are more efficient than the reference solution. This result gives us an idea of the

effectiveness of these new solutions according to the right choices of design parameters for maintenance, such as the monitoring integration, redundancy, components choice, accessibility as shown in Figures 5. This shows the value of this tool allowing designers to visualize the consequences of their design decision on LCC and on TOR. Thus, will be able to guide the design according to the economic models in which the future product will be exploited.

In this context of various optimal Pareto solutions, it will be difficult to choose the best solution. There are methods to determine the best solution in a set of Pareto solutions. The  $L_2$ -norm method is proposed by [57, 58], is widely used. This technique calculates the standardized minimum distance of the whole set of Pareto solutions. Then it, selects the solution that has the most optimal value. The equation is given by [59] :

$$Min \left[ \sum_{z=1}^w \left( \frac{f_z(x) - f_z^{min}}{f_z^{max} - f_z^{min}} \right)^2 \right]^{\frac{1}{2}} \quad (21)$$

Where  $w$  is the number of the objective function,  $f_z(x)$  the optimal value of a Pareto frontier, and  $f_z^{min}$  and  $f_z^{max}$  are the minimum and maximum values of the  $z$ -th objective function of the optimal set of Pareto. In this formula, all objective functions must be minimized.

In this illustration, we apply the  $L_2$ -norm method to select the best design solution from the set of Pareto solutions in Figure 4. We choose here to take only 10 Pareto solutions (points marked in red in Figure 4) in order to easily illustrate and justify the results obtained by this technique. To use this technique, first, the objective function related to operational reliability (maximizing the operational reliability of the system) must be transformed into minimization. To do this, the system's unreliability is calculated. Next, we evaluate the distance defined in equation (21) for each optimal solution. Table 4 shows the distance of the 10 optimal solutions with the best one marked in bold. The characteristics of the most optimal solutions are presented in Table 5. Thus, Figure 6 illustrates the structure of this best non-dominated solution.

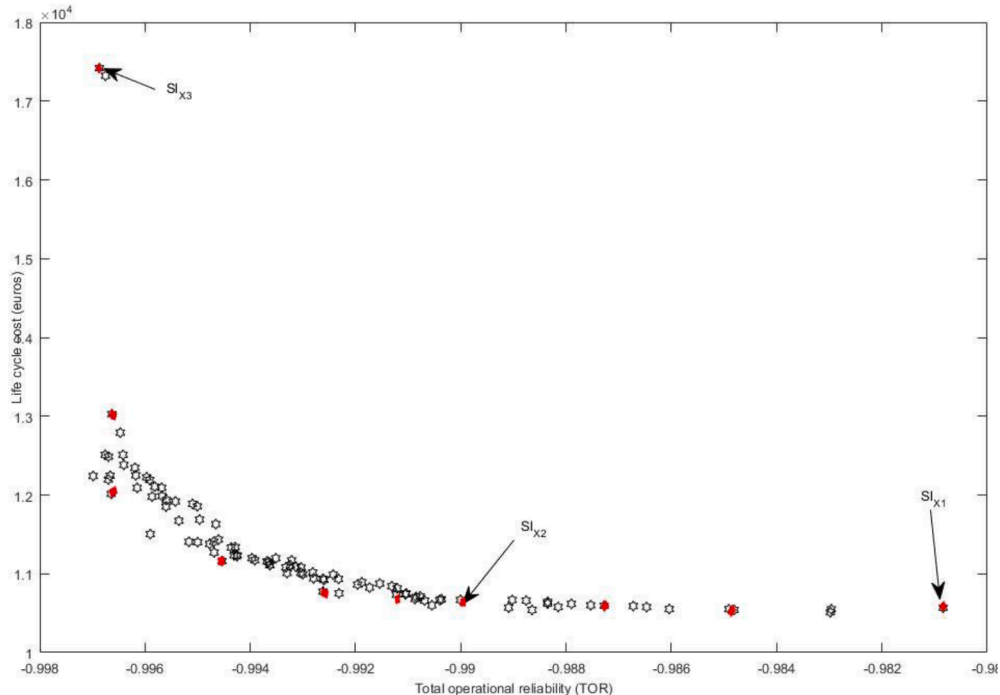
**Figure 4.** Set of Pareto Design Solutions.

**Table 3**The characteristics of Pareto's solutions  $Sl_{x1}$ ,  $Sl_{x2}$  et  $Sl_{x3}$ .

		C1 & C1'	C2 & C2'	C3 & C3'	C4 & C4'	C5	$LCC_{sys}^{mean} \times e4$	$TOR_{sys}^{mean}$
$Sl_0$	Refer to Table 1						2.5208	0.812
$Sl_{x1}$	$R_i$ (KM)	W(3.8e5,10)	W(4.5e5,5)	W(5.5e5,10)	W(5.5e5,6)	G(15e-5,0.9) $L = 20$	1.0591	0.982
	$MTTR_i$ (h)	1.3	1.1	0.9	1.3	0.9		
	$S_i$	1	0	0	0	1		
	$P_i$	1	1	0	0	0		
$Sl_{x2}$	$R_i$	W(3.46e5, 3.2)	W(3.93e5, 8.5)	W(5.38e5, 12)	W(4.9e5, 10)	G(22e-5,0.5) $L = 20$	1.1145	0.989
	$MTTR_i$	0.9	1.2	1.0	1.2	0.9		
	$S_i$	1	0	0	1	1		
	$P_i$	1	1	1	0	0		
$Sl_{x3}$	$R_i$	W(3.6e5, 8)	W(4.23e5, 10)	W(5.3e5, 9)	W(5.3e5, 9)	G(13e-5,0.3) $L = 20$	1.7525	0.997
	$MTTR_i$	1.1	1.1	1.2	1.2	1		
	$S_i$	1	1	0	0	1		
	$P_i$	1	1	1	1	0		

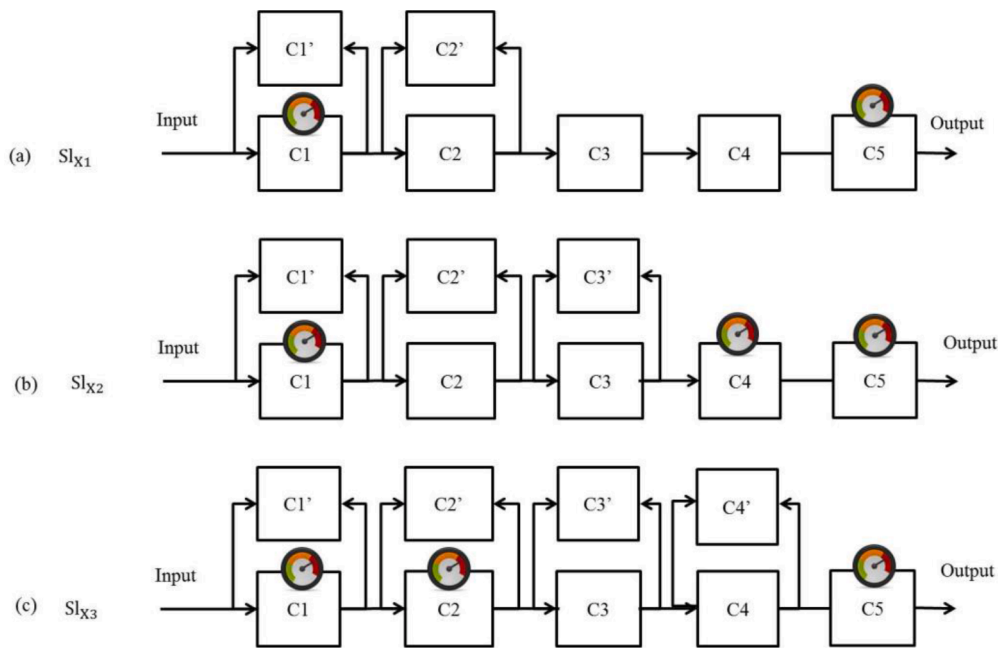
**Figure 5.** (a)  $Sl_{x1}$  Structure; (b)  $Sl_{x2}$  Structure; (c)  $Sl_{x3}$  Structure.

## 7. Conclusions and Perspectives

This research has two major interests. The first is to find the design that maximizes system performance in TOR at the lowest LCC. The second is to allow designers to experiment with several possible solutions by adjusting design variables, objectives and maintenance constraints.

**Table 4**

Characteristics of the 10 Pareto solutions marked in red.

Optimal solutions marked in red	$LCC_{sys}^{mean} \times 10^4$	$1 - TOR_{sys}^{mean}$	Distance $L_2$
1	1.0591	0.0185	1
2	1.0592	0.0152	0.754601
3	1.0621	0.0122	0.570567
4	1.0735	0.0094	0.399275
5	1.0815	0.0073	0.271729
6	<b>1.1105</b>	<b>0.0053</b>	<b>0.163663</b>
7	1.4412	0.0041	0.536288
8	1.2091	0.0032	0.209347
9	1.3064	0.0031	0.344025
10	1.7784	0.0029	1

**Table 5**

Design parameters for the maintenance of the best model of Pareto solutions.

	C1 & C1'	C2 & C2'	C3 & C3'	C4 & C4'	C5
$R_i$ (KM)	W(3.46e5, 3.2)	W(3.63e5, 8.1)	W(4.08e5, 3.5)	W(4.70e5, 6.9)	G(26e-5,0.5) $L = 20$
$MTTR_i$ (h)	1.1	1.2	0.9	1.3	1.0
$S_i$	1	1	1	0	1
$P_i$	1	1	1	1	0

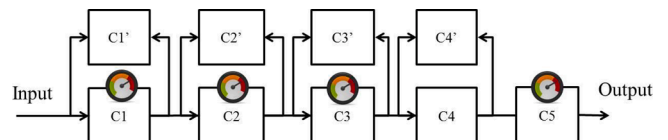
**Figure 6.** Structure of the best model of Pareto solutions.

In this paper, an approach to simultaneous design and maintenance optimization of large-scale multi-component industrial systems has been proposed and tested. This approach is intended to help designers to make compromise decisions for multi-objective design issues. Depending on the intended operating life, the MRP, the design parameters and the MFOP, the tool calculates the solutions set that maximizes TOR and minimizes LCC, it also identifies the compromise solution.

Characterization of design and maintenance are performed by a two-level HAT using genetic algorithms. The first algorithm, considered as main, used Non-Dominated Sorting Genetic Algorithm II (NSGA-II) to identify all design solutions that offers the best combination between  $TOR_{sys}^{mean}(T)$  and  $LCC_{sys}^{mean}(T)$ . The second algorithm used the GA to propose a dynamic maintenance plan that maximizes the  $TOR_{sys}^{mean}(T)$  of each solution of the main algorithm.

The proposed tool HAT was confronted with an example from literature, composed of five components in series. The obtained results proves that this tool made it possible to obtain a set of Pareto solutions. These solutions, which add new components and sensors, have increased the TOR and minimized LCC compared to the initial version, under the same constraints. Indeed, the proposed modifications on the system structure have reduced the probability of occurrence of suspicious events, and increased the robustness of the system. This has resulted in lower total maintenance costs over its lifetime and improved system availability. The Pareto solution set can be a valuable tool for the design team, particularly in finding solutions based on the business model in which the product will operate.

In perspective, several research projects can be investigated, in particular: (a) Adapting the proposed model and procedure to multi-state systems; (b) use other meta-heuristic methods such as PSO and compare them with those of GAs; (c) experiment with the proposed approach for the K-out-of-N subsystems and (d) test the robustness of this model on new examples from industrial world with a sensitivity analysis, in particular the four parameters considered ( $R_i$ ,  $P_i$ ,  $MTTR_i$  and  $S_i$ ).

## Funding

This research did not receive any specific grant from funding agencies in the public, commercial, or not-for-profit sectors.

## Author Statement

All persons who meet authorship criteria are listed as authors, and all authors certify that they have participated sufficiently in the work to take public responsibility for the content, including participation in the concept, design, analysis, writing, or revision of the manuscript. Furthermore, each author certifies that this material or similar material has not been and will not be submitted to or published in any other publication before its appearance in the Reliability Engineering & System Safety.

## Specific contributions made by each author

**Adjoul, O:** Methodology, Software, Formal analysis, Writing - Original Draft, Writing - Review & Editing. **Benfriha, K:** Conceptualization, Supervision, Writing - Review & Editing. **El zant, C:** Review - Original Draft, Visualization. **Aoussat, A:** Project administration

## Declaration of Competing Interest

The authors declare that they have no known competing financial interests or personal relationships that could have appeared to influence the work reported in this paper.

## References

- Markeset T, Kumar U. Design and development of product support and maintenance concepts for industrial systems. *J. Qual. Maint. Eng., avr.* 2013. <https://doi.org/10.1108/13552510310503231>.
- Markeset T, Kumar U. « R&M and risk-analysis tools in product design, to reduce life-cycle cost and improve attractiveness. Annual Reliability and Maintainability Symposium. In: 2001 Proceedings. International Symposium on Product Quality and Integrity (Cat. No.01CH37179). Philadelphia, PA, USA; 2001. p. 116–22. <https://doi.org/10.1109/RAMS.2001.902452>.
- Dhillon BS. Maintainability, Maintenance, and Reliability for Engineers. CRC Press; 2006.
- Kusiak A, Li W. « The prediction and diagnosis of wind turbine faults. *Renew. Energy* 2011;36(1):16–23. <https://doi.org/10.1016/j.renene.2010.05.014>.
- Goel HD, Grievink J. Integrated optimal reliable design, production, and maintenance planning for multipurpose process plants. *Comput. Chem. Eng.* 2003; 27(11):1543–55. [https://doi.org/10.1016/S0098-1354\(03\)00090-5](https://doi.org/10.1016/S0098-1354(03)00090-5).
- Rawat M, Lad BK. « Simultaneous selection of reliability design and level of repair for fleet systems. *Int. J. Syst. Assur. Eng. Manag.* 2016;7(2):138–55. <https://doi.org/10.1007/s13198-016-0429-z>.
- Kuo T-C, Huang SH, Zhang H-C. « Design for manufacture and design for 'X': concepts, applications, and perspectives. *Comput. Ind. Eng.* 2001;41(3):241–60. [https://doi.org/10.1016/S0360-8352\(01\)00045-6](https://doi.org/10.1016/S0360-8352(01)00045-6).
- Boothroyd G, Dewhurst P, Knight WA, Dewhurst P, Knight WA. *Product Design for Manufacture and Assembly, Revised and Expanded*. CRC Press; 2001.
- Stoll HW. Design for manufacture. *Manuf. Eng.* 1988;100(1):67–73. n.
- Corbett J. *Design for manufacture: strategies, principles, and techniques*. Addison Wesley publishing company; 1991.
- Adjoul O, Benfriha K, Aoussat A. Algorithmic strategy for optimizing product design considering the production costs. *Int. J. Interact. Des. Manuf. IJIDeM* 2019; 13(4):1313–29. <https://doi.org/10.1007/s12008-019-00571-w>.
- Chen L, Cai J. Using Vector Projection Method to evaluate maintainability of mechanical system in design review. *Reliab. Eng. Syst. Saf.* 2003;81(2):147–54. [https://doi.org/10.1016/S0951-8320\(03\)00075-9](https://doi.org/10.1016/S0951-8320(03)00075-9).
- Markeset T. Dimensioning of product support: Issues, challenges, and opportunities. 2003.
- H. Zoufaghari, A. Zeinal Hamadani, and M. Abouei Ardakan, « Bi-objective redundancy allocation problem for a system with mixed repairable and non-repairable components », *ISA Trans.*, vol. 53, n 1, p. 17–24, janv. 2014, doi: 10.1016/j.isatra.2013.08.002.
- Beaurepaire P, Valdebenito MA, Schuëller GI, Jensen HA. « Reliability-based optimization of maintenance scheduling of mechanical components under fatigue. *Comput. Methods Appl. Mech. Eng.* 2012;221–222:24–40. <https://doi.org/10.1016/j.cma.2012.01.015>.
- Ebrahimipour V, Sheikhalshahi M. Application of multi-objective particle swarm optimization to solve a fuzzy multi-objective reliability redundancy allocation problem. In: 2011 IEEE International Systems Conference, avr; 2011. p. 326–33. <https://doi.org/10.1109/SYSCON.2011.5929085>.
- Nourelfath M, Ait-Kadi D. « Optimization of series-parallel multi-state systems under maintenance policies ». *Reliab. Eng. Syst. Saf.* 2007;92(12):1620–6. <https://doi.org/10.1016/j.res.2006.09.016>.
- Okasha NM, Frangopol DM. Lifetime-oriented multi-objective optimization of structural maintenance considering system reliability, redundancy and life-cycle cost using GA. *Struct. Saf.* 2009;31(6):460–74. <https://doi.org/10.1016/j.strusafe.2009.06.005>.
- Torres-Echeverría AC, Martorell S, Thompson HA. « Multi-objective optimization of design and testing of safety instrumented systems with MooN voting architectures using a genetic algorithm. *Reliab. Eng. Syst. Saf.* 2012;106:45–60. <https://doi.org/10.1016/j.res.2012.03.010>.
- Amari SV, Pham H. A Novel Approach for Optimal Cost-Effective Design of Complex Repairable Systems. *IEEE Trans. Syst. Man Cybern. - Part Syst. Hum.* 2007;37(3):406–15. <https://doi.org/10.1109/TSMCA.2007.893454>.
- Chang C-C, Sheu S-H, Chen Y-L. Optimal replacement model with age-dependent failure type based on a cumulative repair-cost limit policy. *Appl. Math. Model.* 2013;37(1):308–17. <https://doi.org/10.1016/j.apm.2012.02.031>.
- Sriramdas V, Chaturvedi SK, Gargama H. « Fuzzy arithmetic based reliability allocation approach during early design and development ». *Expert Syst. Appl.* 2014;41(7):3444–9. <https://doi.org/10.1016/j.eswa.2013.10.048>.
- Tsai Y-T, Wang K-S, Tsai L-C. « A study of availability-centered preventive maintenance for multi-component systems. *Reliab. Eng. Syst. Saf.* 2004;84(3): 261–70. <https://doi.org/10.1016/j.res.2003.11.011>.
- Yao Y, He P, Zheng Z, Tan C, Yuan Y. Joint Redundancy and Inspection-Based Maintenance Optimization for Series-Parallel System. In: Wang G, Zomaya A, Martinez G, editors. *Algorithms and Architectures for Parallel Processing*, 9530. Cham: Springer International Publishing; 2015. p. 741–55. K. Li, Éd.
- Atashgar K, Abdollahzadeh H. « Reliability optimization of wind farms considering redundancy and opportunistic maintenance strategy. *Energy Convers. Manag.* 2016;112:445–58. <https://doi.org/10.1016/j.enconman.2016.01.027>.
- Valdebenito MA, Schuëller GI. « Design of maintenance schedules for fatigue-prone metallic components using reliability-based optimization. *Comput. Methods Appl. Mech. Eng.* 2010;199(33):2305–18. <https://doi.org/10.1016/j.cma.2010.03.028>.
- Rawat M, Lad BK. Novel approach for machine tool maintenance modelling and optimization using fleet system architecture. *Comput. Ind. Eng.* 2018;126:47–62. <https://doi.org/10.1016/j.cie.2018.09.006>.

- [28] Rawat M, Lad BK. An integrated strategy for fleet maintenance planning. *J. Qual. Maint. Eng.* 2017;23(4):457–78. <https://doi.org/10.1108/JQME-03-2016-0013>. n°janv.
- [29] Mulder W, Basten RJJ, Becker JMJ, Van Dongen LAM. Work in Progress: Developing Tools that Support the Design of Easily Maintainable Rolling Stock », *Procedia CIRP*, 11; 2013. p. 204–6. <https://doi.org/10.1016/j.procir.2013.07.034>. janv.
- [30] Pistikopoulos EN, Vassiliadis CG, Papageorgiou LG. « Process design for maintainability: an optimization approach. *Comput. Chem. Eng.* 2000;24(2): 203–8. [https://doi.org/10.1016/S0098-1354\(00\)00514-7](https://doi.org/10.1016/S0098-1354(00)00514-7). n°juill.
- [31] Alaswad S, Xiang Y. A review on condition-based maintenance optimization models for stochastically deteriorating system. *Reliab. Eng. Syst. Saf.* 2017;157: 54–63. <https://doi.org/10.1016/j.res.2016.08.009>. janv.
- [32] Olde Keizer MCA, Teunter RH, Veldman J. « Clustering condition-based maintenance for systems with redundancy and economic dependencies ». *Eur. J. Oper. Res.* 2016;251(2):531–40. <https://doi.org/10.1016/j.ejor.2015.11.008>. n°juin.
- [33] Tian Z, Jin T, Wu B, Ding F. « Condition based maintenance optimization for wind power generation systems under continuous monitoring. *Renew. Energy* 2011;36 (5):1502–9. <https://doi.org/10.1016/j.renene.2010.10.028>. mai.
- [34] Lesobre R, Bouvard K, Berenguer C, Barros A, Cocquemot V. « A maintenance free operating period policy for a multi-component system with different information levels on the components state. *Chem. Eng. Trans.* 2013;1051–6. <https://doi.org/10.3303/CET1333176>. juill.
- [35] Cheng GQ, Zhou BH, Li L. « Integrated production, quality control and condition-based maintenance for imperfect production systems. *Reliab. Eng. Syst. Saf.* 2018; 175:251–64. <https://doi.org/10.1016/j.res.2018.03.025>. juill.
- [36] Castanier B, Grall A, Bérenguer C. « A condition-based maintenance policy with non-periodic inspections for a two-unit series system. *Reliab. Eng. Syst. Saf.* 2005; 87(1):109–20. <https://doi.org/10.1016/j.res.2004.04.013>. n°janv.
- [37] Olde Keizer MCA, Teunter RH, Veldman J. « Joint condition-based maintenance and inventory optimization for systems with multiple components ». *Eur. J. Oper. Res.* 2017;257(1):209–22. <https://doi.org/10.1016/j.ejor.2016.07.047>. n°févr.
- [38] Wildeman R, Dekker R, Smit ACJM. A dynamic policy for grouping maintenance activities. *Eur. J. Oper. Res.* 1997;99(3):530–51. [https://doi.org/10.1016/S0377-2217\(97\)00319-6](https://doi.org/10.1016/S0377-2217(97)00319-6). n°juin.
- [39] Bouvard K, Artus S, Bérenguer C, Cocquemot V. « Condition-based dynamic maintenance operations planning & grouping. Application to commercial heavy vehicles. *Reliab. Eng. Syst. Saf.* 2011;96(6):601–10. <https://doi.org/10.1016/j.res.2010.11.009>. n°juin.
- [40] Do Van P, Barros A, Bérenguer C, Bouvard K, Brissaud F. « Dynamic grouping maintenance with time limited opportunities. *Reliab. Eng. Syst. Saf.* 2013;120: 51–9. <https://doi.org/10.1016/j.res.2013.03.016>. déc.
- [41] Van PD, Vu HC, Barros A, Berenguer C. « Grouping maintenance strategy with availability constraint under limited repairs. *IFAC Proc. Vol.*, vol. 2012;45(20): 486–91. <https://doi.org/10.3182/20120829-3-MX-2028.00194>. n°janv.
- [42] Vu HC, Do P, Barros A, Berenguer C. « Maintenance planning and dynamic grouping for multi-component systems with positive and negative economic dependencies. *IMA J. Manag. Math.* 2015;26(2):145–70. <https://doi.org/10.1093/imaman/dpu007>. n°avr.
- [43] Vu HC, Do Van P, Barros A, Bérenguer C. Maintenance activities planning and grouping for complex structure systems. In: 11th International Probabilistic Safety Assessment and Management Conference & the Annual European Safety and Reliability Conference - PSAM 11/ESREL 2012; 2012. juin 2012, p. CDROM, Consulté le: avr. 08, 2020. [En ligne] Disponible sur, <https://hal.archives-ouvertes.fr/hal-00695783>.
- [44] Lesobre R, Bouvard K, Bérenguer C, Barros A, Cocquemot V. « Evaluation of decision criteria to optimize a dynamic maintenance policy based on Maintenance Free Operating Period concept. In: 8th IMA International Conference on Modelling in Industrial Maintenance and Reliability (MIMAR)18; 2014. p. 173–8. juill. Consulté le: déc2018 [En ligne]. Disponible su, <https://hal.archives-ouvertes.fr/hal-01243647>.
- [45] Chambari A, Rahmati SHA, Najafi AA, karimi A. « A bi-objective model to optimize reliability and cost of system with a choice of redundancy strategies. *Comput. Ind. Eng.* 2012;63(1):109–19. <https://doi.org/10.1016/j.cie.2012.02.004>. n°août.
- [46] Khalili-Damghani K, Abtahi A-R, Tavana M. « A new multi-objective particle swarm optimization method for solving reliability redundancy allocation problems. *Reliab. Eng. Syst. Saf.* 2013;111:58–75. <https://doi.org/10.1016/j.res.2012.10.009>. mars.
- [47] de Almeida AT, Ferreira RJP, Cavalcante CAV. « A review of the use of multicriteria and multi-objective models in maintenance and reliability. *IMA J. Manag. Math.* 2015;26(3):249–71. <https://doi.org/10.1093/imaman/dpv010>. n°juill.
- [48] A. Monga and M. J. Zuo, « Optimal system design considering maintenance and warranty », *Comput. Oper. Res.*, vol. 25, no 9, p. 691–705, sept. 1998, doi: 10.1016/S0305-0548(98)00025-2.
- [49] Hockley CJ, Appleton DP. Setting the requirements for the Royal Air Force's next generation aircraft. In: *Annual Reliability and Maintainability Symposium*; 1997. p. 44–9. <https://doi.org/10.1109/RAMS.1997.571662>. janv.
- [50] Cini PF, Griffith P. « Designing for MFOP: towards the autonomous aircraft. *J. Qual. Maint. Eng.* 1999;5(4):296–308. <https://doi.org/10.1108/13552519910298055>. n°déc.
- [51] Dinesh Kumar U, Knezevic J, Crocker J. « Maintenance free operating period – an alternative measure to MTBF and failure rate for specifying reliability? ». *Reliab. Eng. Syst. Saf.* 1999;64(1):127–31. [https://doi.org/10.1016/S0951-8320\(98\)00048-9](https://doi.org/10.1016/S0951-8320(98)00048-9). n°avr.
- [52] Al Shaalane A, Vlok PJ. « Application of the aviation derived maintenance free operating period concept in the South African mining industry », *South Afr. J. Ind. Eng.* 2013;24(3):150–65. n°nov.
- [53] Sinisuka NI, Nugraha H. « Life cycle cost analysis on the operation of power generation. *J. Qual. Maint. Eng.* 2013;19(1):5–24. <https://doi.org/10.1108/13552511311304447>. n°mars.
- [54] Hwang H-S. « Costing RAM design and test analysis model for production facility ». *Int. J. Prod. Econ.* 2005;98(2):143–9. <https://doi.org/10.1016/j.ijpe.2004.05.022>. n°nov.
- [55] B. S. Dhillion, « Life Cycle Costing for Engineers. London », 2010.
- [56] Deb K, Jain S. Multi-Speed Gearbox Design Using Multi-Objective Evolutionary Algorithms. *J. Mech. Des.* 2003;125:609–19. <https://doi.org/10.1115/1.1596242>.
- [57] Eschenauer H, Koski J, Osyczka A. *Multicriteria Design Optimization: Procedures and Applications*. Springer Science & Business Media; 1990.
- [58] Amiri M, Khajeh M. Developing a bi-objective optimization model for solving the availability allocation problem in repairable series-parallel systems by NSGA II ». *J. Ind. Eng. Int.* 2016;12(1):61–9. <https://doi.org/10.1007/s40092-015-0128-4>. n°mars.
- [59] E. M. Kasprzak and K. E. Lewis, « An Approach to Facilitate Decision Tradeoffs in Pareto Solution Sets », p. 22, 2000.