



Science Arts & Métiers (SAM)

is an open access repository that collects the work of Arts et Métiers Institute of Technology researchers and makes it freely available over the web where possible.

This is an author-deposited version published in: <https://sam.ensam.eu>
Handle ID: <http://hdl.handle.net/10985/8861>

To cite this version :

Seifeddine BENELGHALI, Mohamed BENBOUZID, Jean-Frederic CHARPENTIER - Implications of Control Schemes for Electrical system design in tidal energy converters - 2013

Any correspondence concerning this service should be sent to the repository

Administrator : scienceouverte@ensam.eu



8.2 Implications of control schemes for electrical system design in tidal energy converters

S. Benelghali, M. Benbouzid and JF Charpentier

Nomenclature

ϕ	Flux
β	Pitch angle
σ	Total leakage coefficient, $\sigma = 1 - M^2/L_s L_r$
Ω_{gen}	Mechanical speed ($\Omega = \omega/p$)
C_p	Power coefficient
d, q	Synchronous reference frame index
h	=Viscosity coefficient
J	=Rotor inertia
$I(M)$	Inductance (mutual inductance)

$P(Q)$	Active (Reactive) power
p	= Pole pair number
R	Resistance
$s, (r)$	Stator (rotor) index (superscripts)
$T_{em}(T_{gen})$	Electromagnetic torque (Mechanical torque)
$V(I)$	Voltage (current)
V_{tides}	= Tidal current speed
η	= Mechanical efficiency of the turbine power train
θ_r	Rotor position
λ	= Tip-speed ratio
$\omega(\omega_s)$	Rotor electrical speed (electrical synchronous speed)

The tidal current turbulences and the system parameter drift due to the system wear can significantly influence the dynamic performance of a tidal turbine. In this context, various control techniques suitable to any particular turbine configuration can be used. In most cases, classical PI or PID control are preferred. In this section, a review of control strategies for tidal energy is presented. These strategies are mainly inspired from common practices developed for wind turbine applications.

AQ3

8.2.1 General control strategy for tidal current energy extraction

Figure 8.5 shows an idealized power extracting strategy for a tidal turbine device. Such power strategy is generally used as the basis of control strategies for harnessing energy from tidal turbines.

The tidal turbine does not operate below a pre-defined cut-in tidal velocity, V_c . As the tidal velocity (V) increases above the turbine's cut-in speed, the power delivered by the generator increases proportionally to the cube of the tidal velocity by following a maximum power point tracking (MPT) strategy. When the tidal velocity reaches the rated tidal speed V_R , the generator/converter set is delivering as

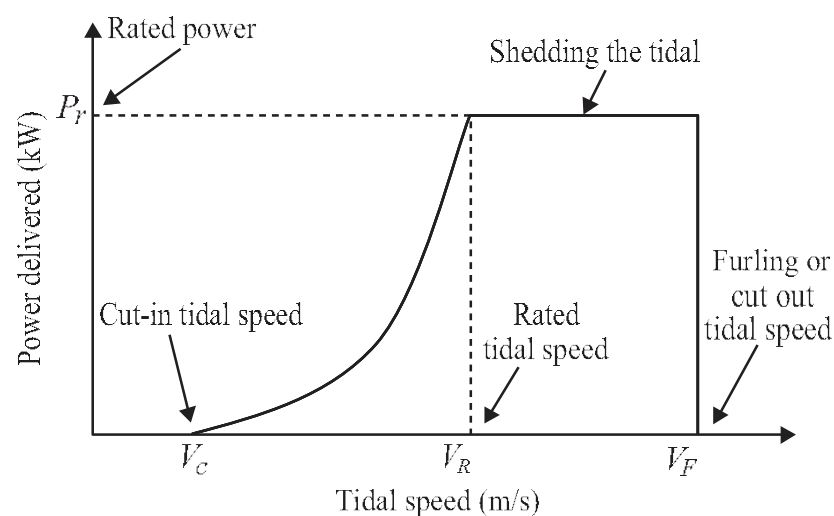

Figure 8.5 Idealized power curve

much power as it is designed for and the power has to be limited. Power output remains constant as the tidal velocity increases above the rated velocity.

The **MPT** strategy and the power limitation can be achieved using (8.14) pitch control with variable pitch systems, (8.15) variable speed systems with fixed pitch systems or (8.16), a combination of these two principles.

8.2.2 Fixed-speed variable-pitch tidal turbine

In this case, optimization of the harnessing strategy involves using the $C_p(\lambda, \beta)$ characteristic (see section 9.1). If $V < V_R$ one finds the optimum of $C_p(\lambda, \beta)$ using a look-up table interpolation. Under constant-speed operation (i.e. fixed turbine rotational speed), this curve depends on the pitch angle, β , and the tidal speed V_{tides} . Optimization is achieved by changing the angle β , such that the operating point to be placed at the maximum of $C_p(\beta)$ corresponds to the tidal speed when the fluid speed is lower than V_R . If the speed is higher than V_R the pitch angle is then chosen to limit the power or to cut out the power (for extreme tidal velocity values) (Figure 8.6).

AQ4

AQ5

8.2.3 Variable-speed fixed-pitch turbine

Control of variable-speed fixed-pitch turbine generally aims to regulate the power harvested from the tidal currents by modifying the speed of the generator. In particular, the control goal is to capture the maximum power available from the tidal stream. For a tidal velocity lower than V_R , there is an optimum turbine rotational speed which produces a maximum power coefficient, C_p . For tidal velocities higher than V_R the rotational speed is chosen to limit the turbine's output power to the rated power of the generator and drive set. In this case, the reference speed is chosen to be higher than the speed corresponding to the maximum value of C_p in order to limit the torque value and to operate in a stable zone of the power curve.

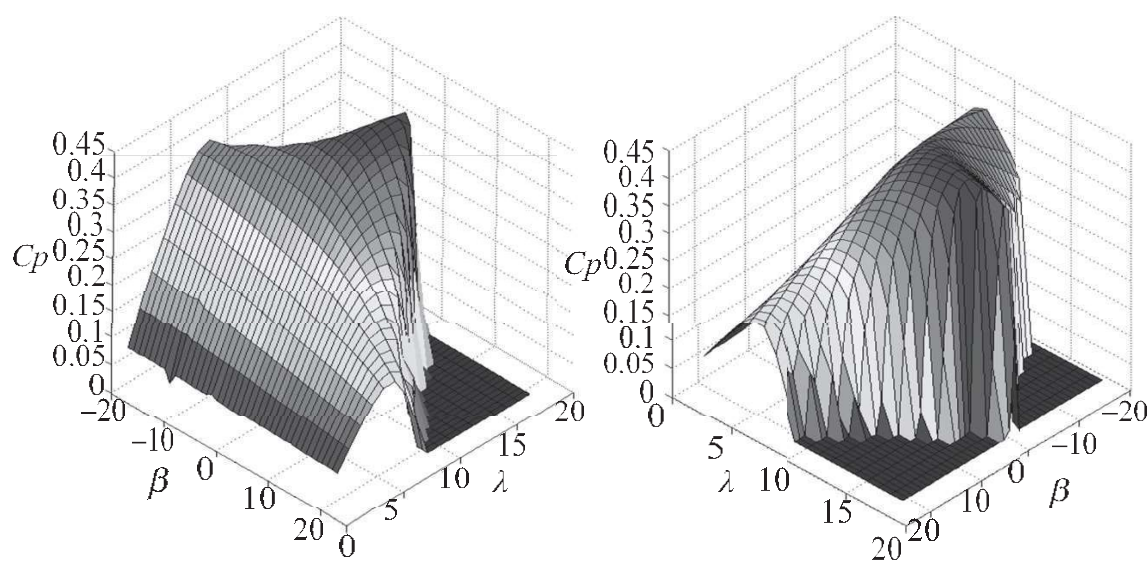

Figure 8.6 $C_p(\lambda, \beta)$ curves

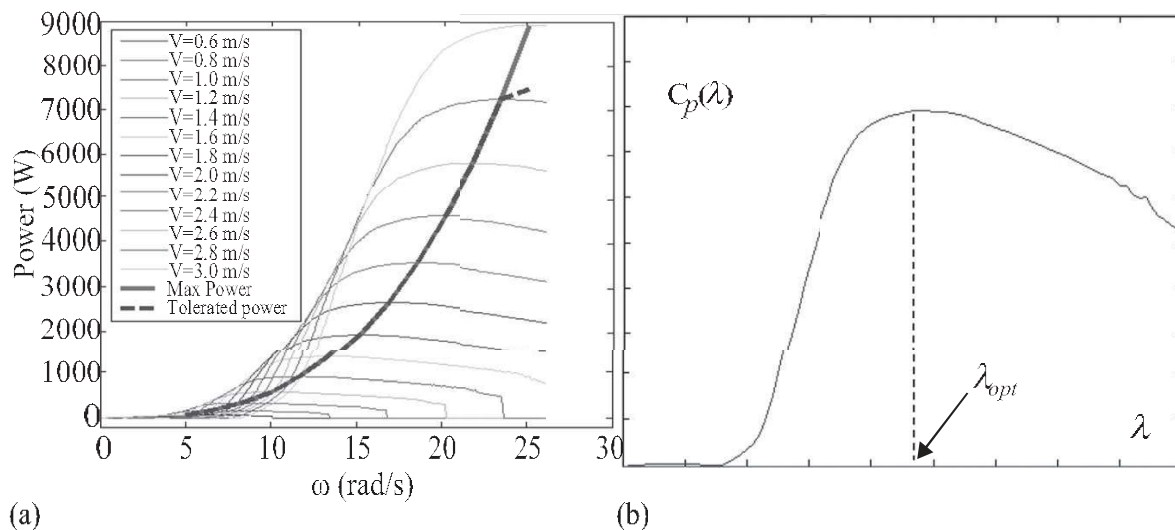

Figure 8.7 (a) Power curves for different tidal current speed; (b) power coefficient curve

All these reference speeds (as a function of the value of tidal velocity) compose what is known as the ORC (optimal regimes characteristic) in the literature (Figure 8.7(a)) [1, 2]. By keeping the static operating point of the turbine around the ORC, one ensures an optimal steady-state regime. In this case, the captured power is the maximum available from the tidal stream. This is equivalent to maintaining the TSR at its optimal value λ_{opt} for $V < V_R$ (Figure 8.7(b)). Maintaining the TSR at its optimal value can be achieved by operating the turbine at variable speed, according to the tidal speed [1]. Of course, this kind of strategy is only possible if the generator and drive set is able to control the speed in the corresponding range.

Basically, the control strategies vary in accordance with assumptions concerning the known models/parameters, the measurable variables, and the used tidal turbine model. Depending on how rich the information are about the turbine model, especially about its torque and power characteristic, the optimal control of a variable-speed fixed-pitch turbine is based upon the following approaches, when $V < V_R$.

8.2.3.1 Maximum power point tracking (MPPT) strategy

This approach is adequate when parameters λ_{opt} and $C_{pmax} = C_p(\lambda_{opt})$ are unknown. The reference of the rotational speed control loop is adjusted such that the turbine operates around the maximum power for the tidal velocity [1, 2]. To establish whether this reference must be either increased or decreased, it is necessary to estimate the current position of the operating point in relation to the maximum of the $P_{TURB}(\omega)$ curve. This can be done in two ways:

- The speed reference is modified by a speed variation, $\Delta\omega$. The corresponding change in the active power (ΔP_{TURB}) is determined in order to estimate the value $\frac{\partial P_{TURB}}{\partial \omega}$. The sign of this value indicates the position of the operating point in relation to the maximum of the $P_{TURB}(\omega)$ characteristic. If the speed reference is adjusted linearly with a slope proportional to this derivative, then the system evolves to the optimum where $\frac{\partial P_{TURB}}{\partial \omega} = 0$.

- A probing signal is added to the tidal current speed reference. This signal is a slowly varying sinusoid. Its amplitude does not significantly affect the system operation, but still produces a detectable response in the active power evolution. In order to obtain the position of the operating point in relation to the maximum, one compares the phase lag of the probing sinusoid and that of the active power sinusoidal component. If the phase lag is 0, then the operating point is placed on the ascending part of $P_{TURB}(\omega)$, while if the phase lag is π , then the operating point is placed on the descending part of $P_{TURB}(\omega)$. Therefore, the slope of the speed reference must increase/decrease. Around the maximum, the probing signal does not produce any detectable response and the speed reference does not have to change [8].

In this simplified MPPT presentation, factors like the tidal turbulence influences and system dynamics that distort information concerning the operating point position have been neglected. A more detailed description and performance analysis can be found in [1].

8.2.3.2 Shaft rotational speed optimal control

Using a set point from the turbine data

This solution can be applied if the optimal value of the TSR λ_{opt} is known. The turbine operates on the ORC if

$$\lambda(t) = \lambda_{opt} \quad (8.15)$$

which supposes that the shaft rotational speed is closed-loop controlled such that to reach its optimal value:

$$\Omega_{ref} = \frac{\lambda_{opt}}{R} v(t) \quad (8.16)$$

8.2.3.3 Active power optimal control

Using a set-point from the shaft rotational speed data

This method is used when both λ_{opt} and $C_{pmax} = C_p(\lambda_{opt})$ are known. In this case the extracted power can be written as

$$\begin{aligned} \partial P_{TURB} &= \frac{1}{2} C_p(\lambda) \rho \pi R^2 v^3 \\ &= \frac{1}{2} \frac{C_p(\lambda)}{\lambda^3} \rho \pi R^5 v^3 \end{aligned} \quad (8.17)$$

By replacing λ_{opt} and $C_{pmax} = C_p(\lambda_{opt})$, one obtains the power reference for the second region of the power-tidal speed curve.

$$P_{TURB} = P_{ref} = K \omega_{ref}^3 \quad (8.18)$$

where

$$K = \frac{1}{2} \frac{C_p(\lambda_{opt})}{\lambda_{opt}^3} \rho \pi R^5 \quad (8.19)$$

This approach supposes an active power control loop being used, whose reference is deduced from (8.19). This method is widely employed, especially for medium- and high-power wind turbine and can be exploited for marine current turbine [1, 2].

8.2.4 Tidal turbine control

In this section, we introduce some classical PI design of wind turbines that can be used for the turbine control for the three above-mentioned cases.

8.2.4.1 Torque control loop

In order to improve and maximize the captured energy, the rotor turbine must operate at the maximum possible power. Equivalently, this means imposing the electromagnetic torque (T_{ref}) which equals the tidal torque corresponding to the maximum available power. The turbine works at maximal efficiency when turning at optimal TSR λ_{opt} so the maximum power is proportional to the cubed rotational speed eqs. (8.18) and (8.19).

$$T_{ref} = \eta K \omega_{ref}^2 \quad (8.20)$$

Of course if $V > V_R$ the reference torque must be limited to

$$T_{ref} = P_r / \omega \quad (8.21)$$

As the turbine control structure allows the tidal speed to be tracked within admissible limits of mechanical loads, this method can be used as long as it depends only on slow tidal speed variations. For high dynamics turbulent tidal current, filtering is necessary to ensure sufficiently slow closed-loop dynamics. Moreover, this method is strongly sensitive to parametric variations.

8.2.4.2 Speed control loop

The controller design is based upon the turbine linearized model. The simplified closed-loop structure is shown in Figure 8.8. A high gain, K_p , will thereby ensure better tracking performance. However, one must take account of control effort (torque) limitations, so K_p values must also be limited. The zero effect of increasing the overshoot is compensated by first-order filtering of the reference signal (Figure 8.8). Although the steady-state speed error is zero, there will always be nonzero dynamical errors due to the significantly variable reference signal ω_{ref} .

One must note that the imposed closed-loop performances are guaranteed for the chosen operating point. Both the gain and the time constant of the torque

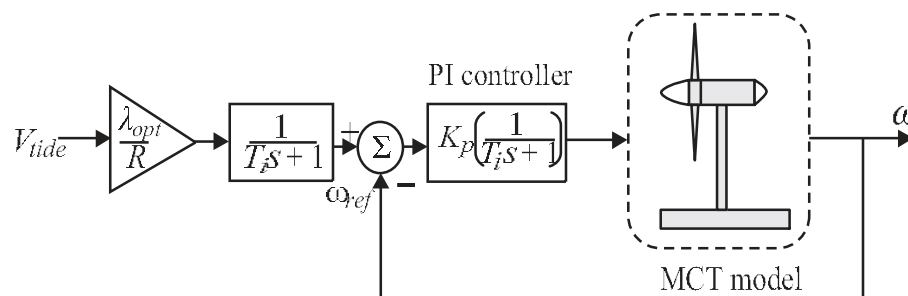

Fig.e 8.8 Turbine PI control structure: speed control loop case

controlled system around a certain steady-state operating point depend on that operating point (through tidal velocity and rotational speed). Therefore, the dynamic performances of the tracking system also vary upon the operating point [1, 2].

8.2.4.3 Power control loop

The input of the system is the electromagnetic torque and its output is the generated active power P . The controller design is based on the parameterization of the system response at step changes in the generator torque for a given tidal speed. The difference between the tidal torque and the electromagnetic torque leads to the variation of the rotational speed, such that the power increases according to the tidal speed dynamics until it reaches a new steady-state value [1, 2, 8].

Example: Optimal control of tidal turbine driven PMSG by PI speed control

As an example, an optimal control based on a PI speed controller has been simulated using a dedicated Matlab/Simulink[®] library presented in [7] for a low-power experimental variable speed fixed-pitch turbine driven PMSG. The control system is defined in the synchronous d - q frame. For the proposed control strategy, the permanent magnet synchronous generator dynamic model is written in the s -domain with the stator voltage given by:

$$\begin{cases} -(R + L_d s)i_d = V_d - \phi_q \omega_s \\ -(R + L_q s)i_q = V_q + \phi_d \omega_s \end{cases} \quad (8.22)$$

The mechanical equation is expressed by

$$T_{gen} - T_{em} = (Js + h)\Omega_{gen} \quad (8.23)$$

where $\Omega = \omega_s/p$ is the mechanical speed and T_{gen} is the mechanical torque provided by the gearbox or directly by the turbine (in direct driven system) to the generator shaft.

The electromagnetic torque T_{em} is defined by

$$T_{em} = \frac{3}{2}p(\phi_d i_q - \phi_q i_d) = \frac{3}{2}p[\phi_m i_q + (L_d - L_q)i_d i_q] \quad (8.24)$$

$$\text{with } \begin{cases} \phi_d = L_d i_d + \phi_m \\ \phi_q = L_q i_q \end{cases}$$

The generator chosen for simulation is a surface mounted permanent magnet synchronous generator; therefore, there are no saliency effects and $L_d = L_q$. So the electromagnetic torque T_{em} can be simplified as

$$T_{em} = \frac{3}{2}p\phi_m i_q \quad (8.25)$$

In those conditions, the PMSG Park model is illustrated by Figure 8.9.

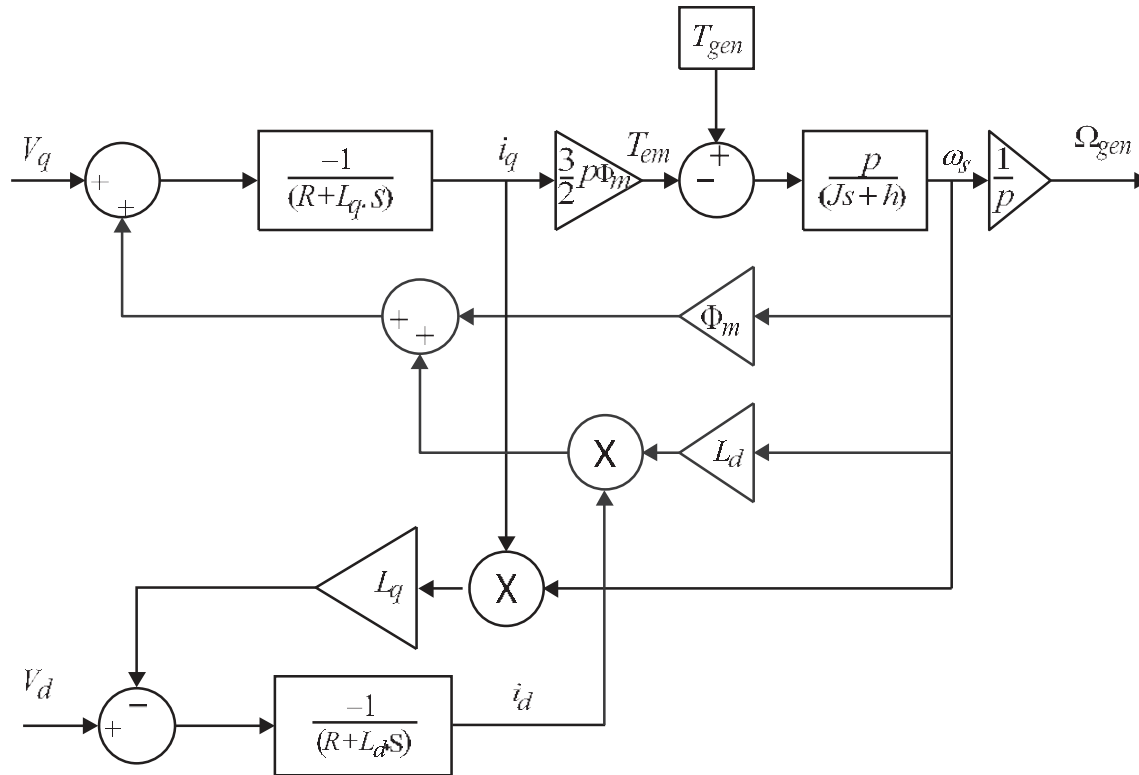

Figure 8.9 *The PMSG Park model*

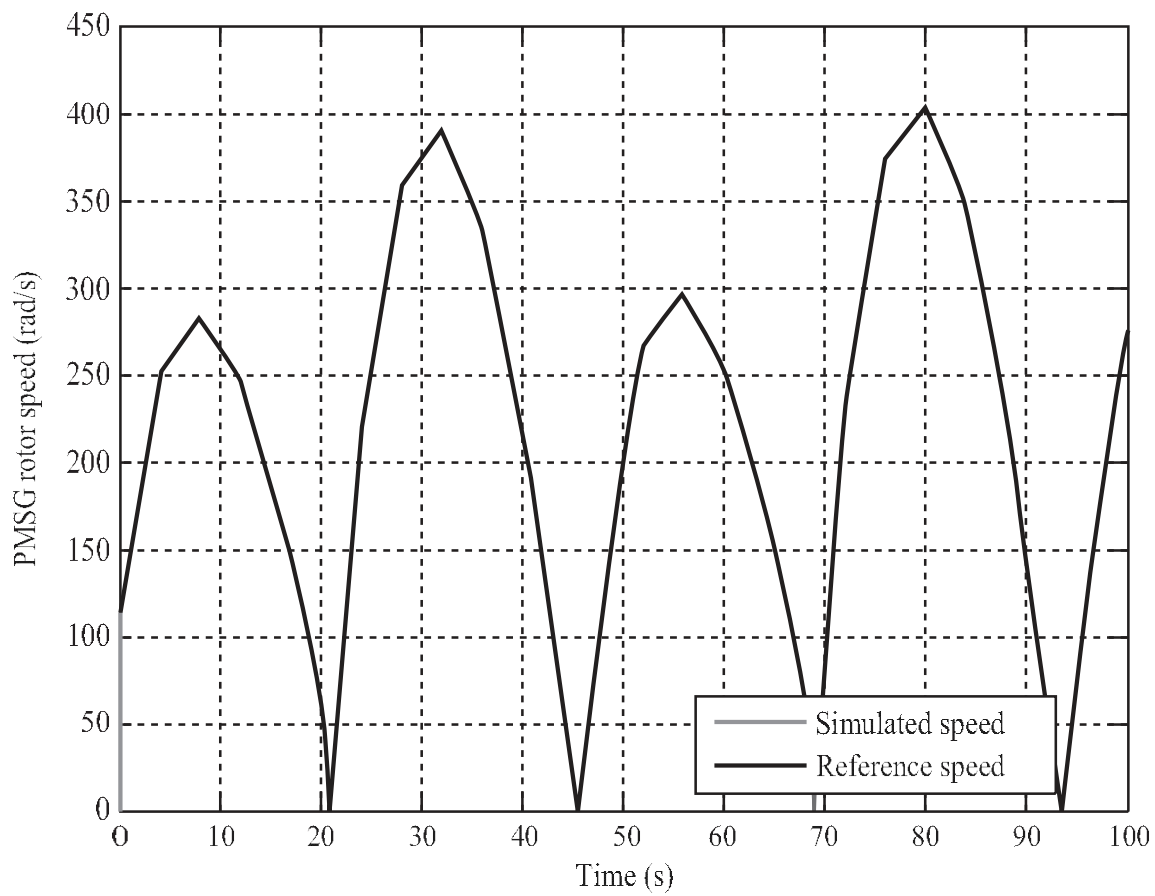

Figure 8.10 *The PMSG rotor speed and its reference*

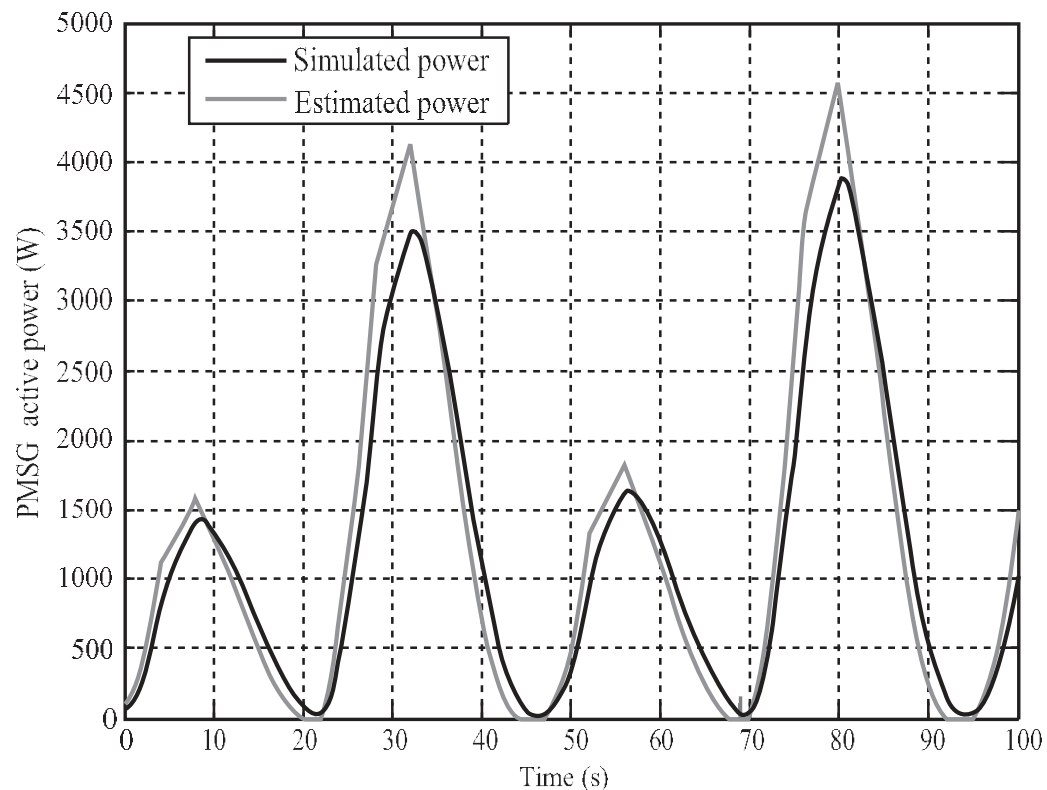

Figure 8.11 The PMSG active power

An inner loop is needed for the current (torque) control. Then an outer loop can be used to control the turbine shaft speed. Indeed, as shown in Figure 8.9 the PMSG rotor speed can be controlled through the rotor current I_q which is proportional to the torque. It can be seen that in the case of a fixed-pitch turbine, power limitation can be achieved using overspeed operations (the generator/converter set must be designed to be controlled in the corresponding speed range).

To illustrate the control behaviour, a PMSG-based turbine is simulated for a varying tidal speed. The PI control strategy is tested for a low power experimental marine current turbine of 1.44 m diameter and 7.5 kW PMSG [3, 4].

For speed references given by the MPPT strategy ($V < V_R$), the PMSG-based turbine control performances are shown in Figure 8.10 and 8.11 respectively illustrating the rotor speed tracking performance and the generated active power.

The estimated power presents the maximum power that can be extracted. It depends on the tidal speed variation and is deduced from the tidal turbine hydrodynamic model. The simulated power presents the measured power generated by the turbine simulator. The obtained results show good tracking performances of the PMSG rotor speed. However, the tidal current turbulences and the system parameter drift due to the system wear out can significantly influence the turbine dynamic performance. In this context, various control techniques, suitable to any particular configuration, can be used. In most cases, classical PI or PID control are preferred. However, advanced control techniques can be used in order to ensure better performances, especially for guaranteeing robustness to modelling uncertainties [3–6].